

**St. Nicholas Magazine for Boys and Girls,
Vol. 5, No. 08, June 1878**

Various and Mary Mapes Dodge



Project Gutenberg

**St. Nicholas Magazine for Boys and Girls,
Vol. 5, No. 08, June 1878**

Various and Mary Mapes Dodge



Project Gutenberg

**The Project Gutenberg eBook of St. Nicholas Magazine for Boys
and Girls, Vol. 5, No. 08, June 1878**

This eBook is for the use of anyone anywhere in the United States and most other parts of the world at no cost and with almost no restrictions whatsoever. You may copy it, give it away or re-use it under the terms of the Project Gutenberg License included with this eBook or online at www.gutenberg.org. If you are not located in the United States, you will have to check the laws of the country where you are located before using this eBook.

Title: St. Nicholas Magazine for Boys and Girls, Vol. 5, No. 08, June 1878

Author: Various

Editor: Mary Mapes Dodge

Release date: June 23, 2005 [eBook #16123]

Most recently updated: December 11, 2020

Language: English

Other information and formats: www.gutenberg.org/ebooks/16123

Credits: Produced by Juliet Sutherland, Lesley Halamek and the
Online Distributed Proofreading Team at <https://www.pgdp.net>

*** START OF THE PROJECT GUTENBERG EBOOK ST. NICHOLAS
MAGAZINE FOR BOYS AND GIRLS, VOL. 5, NO. 08, JUNE 1878 ***

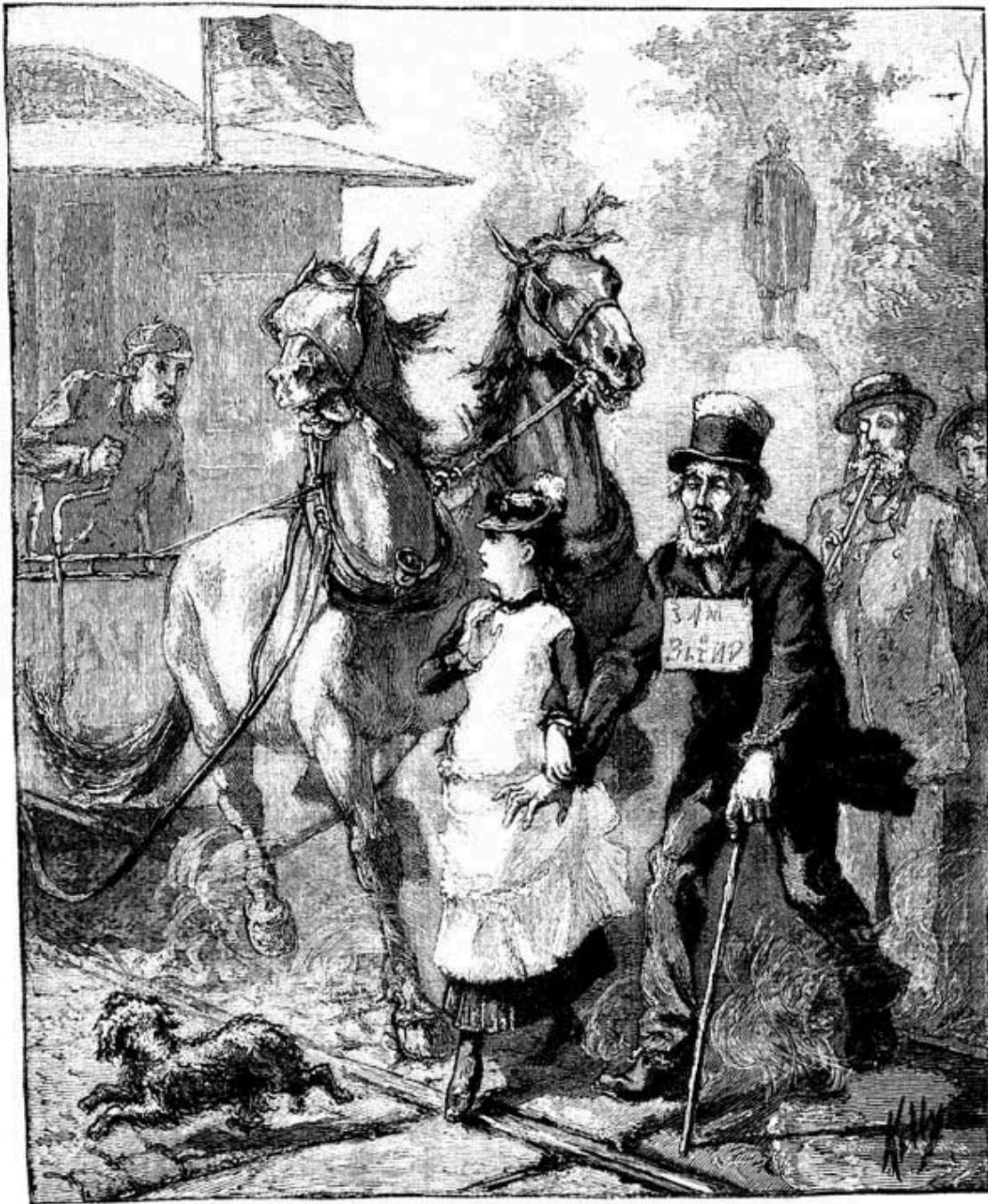

A BRAVE GIRL.

ST. NICHOLAS.

VOL. V. JUNE, 1878. No. 8.

[Copyright, 1878, by Scribner & Co.]

[Transcriber's Note: The Original had no Table of Contents;
I have added one for ease of navigation.
The main Title is the Link.]

CONTENTS

	PAGE
A TRIUMPH. BY CELIA THAXTER.	513
ONE SATURDAY BY SARAH WINTER KELLOGG.	514
MRS. PETER PIPER'S PICKLES. BY E. MÜLLER.	519
UNDER THE LILACS. (Serial) CHAPTER XIV.-SOMEBODY GETS LOST. CHAPTER XV.-BEN'S RIDE. BY LOUISA M. ALCOTT.	523
MASTER MONTEZUMA. <i>(With Illustrations copied from Mexican Hieroglyphics.)</i> By C.C. HASKINS.	535
A LONG JOURNEY. BY JOSEPHINE POLLARD.	540

THE LITTLE RED CANAL-BOAT.	541
BY M.A. EDWARDS.	
THE BUTTERFLY CHASE.	548
BY ELLIS GRAY.	
HOW TO MAKE A TELEPHONE.	549
BY M.F.	
ONLY A DOLL!	552
BY SARAH O. JEWETT.	
DAB KINZER: A STORY OF A GROWING BOY. (Serial)	553
Chapters I, II, III, IV	
BY WILLIAM O. STODDARD.	
HOW WILLY WOLLY WENT A-FISHING.	562
BY S.C. STONE.	
CRUMBS FROM OLDER READING.	565
BY JULIA E. SARGENT.	
III.--THOMAS CARLYLE.	
JACK-IN-THE-PULPIT. (Letter-Box)	566
A ROPE OF EGGS.	
CONVERSATION BY FISTICUFFS.	
A HORSE THAT LOVED TEA.	
TONGUES WHICH CARRY TEETH.	
DIZZY DISTANCES.	
LAND THAT INCREASES IN HEIGHT.	
THE ANGERED GOOSE.	
A CITY UNDER THE WATER.	
REFLECTION.	
"FIDDLE-DIDDLE-DEE!"	568
THE LETTER-BOX. (Dear St. Nicholas)	572
A BRAVE GIRL.	
LETTERS...	
SOME THINGS WHICH WE EXPECT IN YEARS TO COME.	
THE TRUE STORY OF "MARY'S LITTLE LAMB".	
LETTERS...	
ACROSTIC.	
CITY CHILDREN'S COUNTRY REST.	
ANSWERS TO MR. CRANCH'S POETICAL CHARADES received	
from...	
ERRATUM.--	
ANSWERS TO PUZZLES in the April number were received...	
CORRECT SOLUTIONS of all the puzzles were received from...	
THE RIDDLE-BOX.	574
EASY BEHEADINGS.	
ACCIDENTAL HIDINGS.	
METRICAL COMPOSITIONS.	
PORTIONS OF TIME.	
MELANGE.	
EASY CLASSICAL ACROSTIC.	
ENIGMA.	
ANAGRAMS.	
PICTORIAL PUZZLE.	
EASY DIAMOND PUZZLE.	

CHARADE.	
NUMERICAL PUZZLE.	
FOUR-LETTER SQUARE-WORD.	
EASY CROSS-WORD ENIGMA.	
METAGRAM.	
EASY ACROSTIC.	
BLANK WORD-SYNCOPATIONS.	
CHARADE.	
TRANSPOSITIONS OF PROPER NAMES.	
SQUARE-WORD.	
ADDITIONS.	
LABYRINTH.	
ANSWERS TO PUZZLES IN MAY NUMBER.	576

LIST OF ILLUSTRATIONS

	PAGE
A BRAVE GIRL.	<i>Frontispiece</i>
"I BELIEVE SHE'S GONE DRY," SAID KIT.	518
TWO CROWS.	519
THEY TURNED OUT THEIR TOES SO GRACEFULLY.	519
TANGLED IN THE LONG GRASS.	520
OH, MY! HE'S GOING BACKWARDS!	520
THIS IS TWICE AS DEEP AS YOU WERE IN.	521
THERE, IN THE TWILIGHT, HE SAW A LONELY FIGURE STANDING ON ONE LEG.	521
AT THE CIRCUS.	524
BEN AND LITA AT THE BROOK.	529
MASTER MONTEZUMA'S PARENTS TAKE HIM TO THE PRIEST AND THE TEACHER.	536
MASTER MONTEZUMA MUST BE PUNISHED.	537
MASTER MONTEZUMA IS TAUGHT HOW TO FISH.	537
MASTER MONTEZUMA IS TALKED TO BY HIS FATHER.	537
CARRYING THE BRIDE.	538
THE WEDDING OF MONTEZUMA.	538
A PEACE-OFFERING IN THE YEAR ONE RABBIT.	539
PROTECTING THE GRAIN FROM RATS, IN THE YEAR ONE RABBIT.	539
THE EMPEROR MONTEZUMA, SEATED IN THE ROYAL HALLS.	540
CHARLOTTE WAS PUSHING THE BOAT ALONG, MAKING HER WAY TO THE LANDING-STAIRS.	542
AT THE FIRE-WOMAN'S.	544

THE BOYS WITH THEIR BOATS.	546
BELL'S TELEPHONE. Fig. 1 and Fig. 2	550
Fig. 3. A "CIGAR-BOX" TELEPHONE.	551
"POLLY, MY DOLLY! WHY DON'T YOU GROW?"	552
DAB GIVES DICK HIS OLD CLOTHES.	556
"IS YOUR NAME DABNEY KINZER?"	559
MAKING READY FOR A CRUISE.	561
WILLY WOLLY GOING FISHING.	562
WILLY WOLLY CAUGHT HIMSELF.	563
MOTHER UNHOOKS WILLY WOLLY.	564
"JACK-IN-THE-PULPIT."	566
THE ANGERED GOOSE.	567
THE LITTLE BROWN WREN.	568
THE LITTLE BANTAM HEN.	568
THE SPECKLED GUINEA-HEN.	569
THE DUCK.	569
THE DOG.	570
THE HORSE.	570
ALL IN PROCESSION.	571
PICTORIAL PUZZLE.	575
LABYRINTH.	576

A TRIUMPH.

BY CELIA THAXTER.

Little Roger up the long slope rushing
Through the rustling corn,
Showers of dewdrops from the broad leaves brushing
In the early morn,

At his sturdy little shoulder bearing
For a banner gay,
Stem of fir with one long shaving flaring
In the wind away!

Up he goes, the summer sunshine flushing
O'er him in his race,
Sweeter dawn of rosy childhood blushing
On his radiant face.

If he can but set his standard glorious
On the hill-top low,
Ere the sun climbs the clear sky victorious,
All the world aglow!

So he presses on with childish ardor,
Almost at the top!
Hasten, Roger! Does the way grow harder?
Wherefore do you stop?

From below the corn-stalks tall and slender
Comes a plaintive cry—
Turns he for an instant from the splendor
Of the crimson sky,

Wavers, then goes flying toward the hollow,
Calling loud and clear:

"Coming, Jenny! Oh, why did you follow?
Don't you cry, my dear!"

Small Janet sits weeping 'mid the daisies; [Page 514]

"Little sister sweet,
Must you follow Roger?" Then he raises
Baby on her feet,

Guides her tiny steps with kindness tender,
Cheerfully and gay,
All his courage and his strength would lend her
Up the uneven way,

Till they front the blazing East together;
But the sun has rolled
Up the sky in the still Summer weather,
Flooding them with gold.

All forgotten is the boy's ambition,
Low the standard lies,
Still they stand, and gaze—a sweeter vision
Ne'er met mortal eyes.

That was splendid; Roger, that was glorious,
Thus to help the weak;
Better than to plant your flag victorious
On earth's highest peak!

ONE SATURDAY

BY SARAH WINTER KELLOGG.

It was an autumn day in the Indian summer time,—that one Saturday. The Grammar Room class of Budville were going nutting; that is, eight of them were going,—"our set," as they styled themselves. Besides the eight of "our set," Bob Trotter was going along as driver, to take care of the horses and spring wagon on arrival at the woods, while the eight were taking care of the nutting and other fun. Bob was fourteen and three months, but he was well-grown. Beside, he was very handy at all kinds of work, as he ought to have been, considering that he had been kept at work since his earliest recollection, to the detriment of his schooling.

It had been agreed that the boys were to pay for the team, while the girls were to furnish the lunch. In order to economize space, it was arranged that all the contributions to the lunch should be sent on Friday to Mrs. Hooks, Clara of that surname undertaking to pack it all into one large basket.

It was a trifle past seven o'clock Saturday morning when Bob Trotter drove up to Mr. Hooks's to take in Clara, she being the picnicker nearest his starting point. He did not know that she was a put off-er. She was just trimming a hat for the ride when Bob's wagon was announced. She hadn't begun her breakfast, though all the rest of the family had finished the meal, while the lunch which should have been basketed the previous night was scattered over the house from the parlor center-table to the wood-shed.

Clara opened a window and called to Bob that she would be ready in a minute. Then she appealed to everybody to help her. There was a hurly-burly, to be sure. She asked mamma to braid her hair; little brother to bring her blue hair-ribbon from her bureau drawer; little Lucy to bring a basket for the prospective nuts; big brother to get the inevitable light shawl which mamma would be sure to make her take along. She begged papa to butter some bread for her, and cut her steak into mouthfuls to facilitate her breakfast, while the maid was put to collecting the widely scattered lunch. Mamma put baby, whom she was feeding, off her lap—he began to scream; [Page 515] little brother left his doughnut on a chair—the cat began to eat it; little Lucy left her doll on the floor—big brother

stepped on its face, for he did not leave his book, but tried to read as he went to get the light shawl; papa laid down his cigar to prepare the put-offer's breakfast—it went out; the maid dropped the broom—the wind blew the trash from the dust-pan over the swept floor. Clara continued to trim the hat. As she was putting in the last pin, mamma reached the tip end of the hair, and called for the ribbon to tie the braid. "Here 'tis," said little brother. "Mercy!" cried Clara, "he's got my new blue sash, stringing it along through all the dust. Goose! do you think I could wear that great long wide thing on my hair?" Little brother said "Scat!" and rushed to the rescue of his doughnut, while Lucy came in dragging the clothes-basket, and big brother entered with mamma's black lace shawl.

"Well, you told me to get a light one," he replied to Clara's impatient remonstrance, while Lucy whimpered that they wouldn't have enough nuts if the clothes-basket wasn't taken along.

However, when Bob Trotter had secured Clara Hooks, the other girls were quickly picked up, and so were the four boys, for Bob was brisk and so were his horses. Dick Hart was the last called for. He had been ready since quarter past six, and with his forehandedness had worried his friends as effectually as the put-offer had hers. When the wagon at last appeared with its load of fun and laughter, he felt too ill-humored to return the merry greetings.

"A pretty time to be coming around!" he grumbled, climbing to his seat. "I've been waiting three hours."

"You houghtn't to 'ave begun to wait so hearly," said Bob, who had some peculiarities of pronunciation derived from his English parentage.

"It would be better for you to keep quiet," Dick retorted. "You ought to have your wages cut, coming around here after nine o'clock. We ought to be out to the woods this minute."

"'Taint no fault of mine that we haint," said Bob, touching up his horses.

"Whose fault is it, if it isn't yours?" Dick asked.

Clara Hooks was blushing.

"Let the sparrer tell who killed Cock Robin," was Bob's enigmatical reply.

"What's he talking about?" said Julius Zink.

"I dunno, and he don't either," replied Dick.

"He doesn't know that or anything else," said Sarah Ketchum.

It was not possible for Sarah to hear a dispute and not become an open partisan.

"I know a lady when I see 'er," said Bob.

"You don't," said Dick, warmly. "You can't parse horse. I heard you try at school once."

"I can curry him," said Bob.

"You said horse was an article."

"So he is, and a very useful harticle."

One of the girls nudged her neighbor, and in a loud whisper intimated her opinion that Bob was getting the better of Dick. At this Dick grew warmer and more boisterous, maintaining that the boys ought not to pay Bob the stipulated price since they were so late in starting.

"Hif folks haint ready I can't 'elp it," said Bob.

"Who wasn't ready?" demanded Constance Faber. "You didn't wait for me, I know."

"And you didn't wait for me or Mat Snead," added Sarah Ketchum, "because we walked down to meet the wagon."

Clara Hooks's face had grown redder and redder during the investigation; but if Clara *was* a put-offer, she was not a coward or a sneak.

"He waited for me," she now said, "but I think it's mean to tell it wherever he goes."

"I haint told it nowheres."

"You just the same as told; you hinted."

"Wouldn't 'ave 'inted ef they hadn't kept slappin' at me," was Bob's defense, which did not go far toward soothing the mortified Clara.

Not all of this party were pert talkers. Two were modest: Valentine Duke and Mat Snead. These sat together, forming what the others called the Quaker settlement, from the silence which prevailed in it. The silence was now broken by a remark from Valentine Duke irrelevant to any preceding.

"Nuts are plentier at Hawley's Grove than at Crow Roost," he jerked, out, and then locked up again.

"Say we go there, then," said Kit Pott.

"Let's take the vote on it. Those in favor of Hawley's say aye."

The ayes came storming out, as though each was bound to be the first and loudest.

"Contrary, no," continued the self-made president; and Bob Trotter voted solidly "No!"

"We didn't ask you to vote," said Dick, returning to his quarrel.

Dick was constitutionally and habitually pugnacious, but he had such a cordial way of forgiving everybody he injured that people couldn't stay mad with him. Indeed, he was quite a favorite.

"I'm the other side of the 'ouse," Bob answered Dick. "You can't carry this hidee through without my 'elp."

"We hired you to take us to the woods."

"You 'ired me and my wagin and them harticles—whoa!" (Bob's "harticles" stopped)—"to take you to Crow Roost. You didn't 'ire me for 'Awley's, and I haint goin' ther' without a new contract."

"What difference is it to you where we go?"^[Page 516] Dick demanded. "You belong to us for the day."

"Four miles further and back,—height miles makes a difference to the harticles."

Murmurs of disapproval rendered Dick bold.

"Suppose we say you've *got* to take us to Hawley's," he said, warmly.

"Suppose you do," said Bob, coolly.

"I'd like to know what you'd say about it," said Dick, warmly.

"Say it and I'll let you know," said Bob, coolly,—so very coolly that Dick was cooled.

A timely prudence enforced a momentary silence. He forebore taking a position he might not be able to hold. "Say, boys, shall we *make* him take us to the grove?"

Bob smiled. Val Duke smiled, too, in his unobtrusive way, and suggested modestly, "We ought to pay extra for extra work."

"Pay him another quarter and be done with it," said Kit Pott.

Beside being good-natured, Kit didn't enjoy the stopping there in the middle of the road.

"It's mighty easy to pay out other people's money," sneered Dick, resenting it that Kit seemed going over to the enemy.

Kit's face was aflame. His father had refused him any money to contribute toward the picnic expenses, and here was Dick taunting him with it before all the girls.

"You boys teased me to come along because you didn't know where to find the nuts," said Kit.

The girls began to nudge each other, making whimpered explanations and commentaries, agreeing that it was mean in Dick to mind Kit, and Clara Hooks spoke up boldly;

"I wanted Kit to come along because he's pleasant and isn't forever quarreling."

"Oh!" Dick sneered more moderately, "we all know you like Kit Pott. You and he had better get hitched; then, you'd be pot-hooks."

This set everybody to laughing, even Dirk's adversary, Bob Trotter.

"Pretty bright!" said Julius Zink.

"Bright, but not pretty," said Mat Snead, blushing at the sound of her voice.

"Hurrah! Mat's waked up," said Julius.

"It's the first time she's spoken since we started," said Sarah Ketchum.

"This isn't the first time you've spoken," Mat quietly retorted, blushing over again.

Everybody laughed again, even Sarah Ketchum.

"Sarah always puts in her oar when there's any water," said Constance Faber.

"I want to know how long we're to sit here, standing in the middle of the road," said Julius.

Again everybody laughed. When grammar-school boys and girls are on a picnic, a thing needn't be very witty or very funny to make them laugh. From the ease with which this party exploded into laughter, it may be perceived that in spite of the high words and the pop-gun firing, there was no deep-seated ill-humor among them.

"To Crow Roost and be done with it!" said Dick.

"All right," assented several voices.

"Crow Roost, Bob, by the lightning express," said Dick, with enthusiasm.

"But, as you were so particular," said Sarah to Bob, "we're going to be, too. We aint going to give you any lunch unless you pay for it."

"Not a mouthful," said Clara.

"Not even a crumb," said Constance.

Nobody saw any dismay in Bob's face.

I don't intend to tell you about all the sayings and all the laughter of those boys and girls on their way to Crow Roost. They wouldn't like to have me, and you wouldn't. Bob Trotter ran over a good many grubs and way-side stumps, and at every jolt Constance screamed, and Dick scolded and then laughed. Mat Snead spoke three words. She and Valentine had been sitting as though in profound meditation for some forty minutes, when he said: "Quite a ride!"

"Very; no, quite," she answered, in confusion.

Sarah Ketchum said everything that Mat didn't say. She was Mat's counterpart.

All grew enthusiastic as they approached the woods, and when the wagon stopped they poured over the side in an excited way.

"What shall we do with the lunch-basket?"

"Leave it in the wagon," said Sarah Ketchum, whose counsel, Kit said, was as free as the waters of the school pump.

Clara objected to leaving it. Bob would eat everything up. "Let's take it along."

"Why, no," said Julius.

He was the largest of the boys, and, according to the knightly code, he remembered the carrying of the basket would devolve upon him.

"Yes, we must carry it along," Sarah Ketchum insisted. "Bob sha'n't have a chance at that basket if I have to carry it around on my back."

Constance, too, said, "Take it along."

"It's easy enough for you girls to insist on having the basket toted around," said Dick, "because girls can't carry anything when there are boys along; but suppose you were a poor little fellow like Jule."

"I wont have to climb the trees with it on my back, will I?" said Julius. "I'll tell you," he continued, lowering his tone—Bob had heard all the preceding remarks—"we'll hang our basket on a hickory limb. It will be safe from hogs, and the leaves will hide it from Bob."

This proposition was approved, and the basket^[Page 517] was carried off a short distance and slyly swung into a sapling. Then the eight went scurrying through the woods, leaving Bob with the horses. Wherever they saw a lemon-tinted tree-top against the sky or crowded into one of those fine autumn bouquets a clump of trees can make, there rushed a squad of boys, each with his basket, followed by a squad of girls, each with her basket.

But in a very short time the girls were tired and the boys hungry. All agreed to go back to the lunch. So back they hurried, the nuts rolling about over the bottoms of the baskets. Julius had the most nuts; he had eleven. Mat had the smallest number; she had one.

"I hope you girls brought along lots of goodies," said Dick. "Seems to me I never was so hungry in my life."

"I believe boys are always hungry," said Sarah Ketchum.

Val Duke was leading the party. He got along faster than the others, because he wasn't turning around every minute to say something. He made an electrifying announcement:

"A cow's in the basket!"

"Gee-whiz!" said Dick, rushing at the cow. "Thunder!" said Julius, and he gathered a handful of dried leaves and hurled them at the beast. Kit said "Ruination!" and threw his cap. Clara said "Begone!" and flapped her handkerchief in a scaring way. Sarah Ketchum said, "Shew! Scat!" and pitched a small tree-top. It hit Dick and Valentine. Constance said "Wretch!" and didn't throw anything. Mat didn't say anything and threw her hickory-nut. Val threw his basket, and hung it on the cow's horn. She shook it off walked away a few yards, then turned and stared at the party.

"Lunch is gone, every smitch of it!" said Kit.

"Hope it'll kill her dead!" said Sarah Ketchum.

"We'd better have left it in the wagon. Bob couldn't have eaten it all," said Clara.

"I wish Jule had taken it along," said Dick.

"I wish Dick had taken it along," said Julius.

"But what're we going to do?" said Constance.

"We might buy something if anybody lived about here."

"There isn't any money."

"Dick might give his note, with the rest of us as indorsers," said Julius.

"We might play tramps and beg something."^[Page 518]

"But nobody lives around here."

"Hurrah!" said Dick, who had been prowling about among the slain. "Here's a biscuit, and here's a half loaf of bread."

"But they're all mussed and dirty," said Sarah.

"You might pare them," Mat suggested.

"Yes, peel them like potatoes," said Julius.

"But what are these among so many? The days of miracles are past."

"What shall we do?" said one and another.

"Milk the cow," said Mat.

Boys and girls clapped their hands with enthusiasm, and cried "Splendid!" "Capital!" etc.

"I'll milk her," said Dick. "Hand me that cup. I'm obliged to the cow for not eating it."

The cow happened to be a gentle animal, so she did not run away at Dick's approach, yet she seemed determined that he should not get into milking position. She kept her broad, white-starred face toward him, and her large, liquid eyes on his, turning, turning, turning, as he tried over and over to approach her flanks, while the others stood watching in mute expectancy.

"Give her some feed," said Mat.

"Feed! I shouldn't think she could bear the sight of anything more after all that lunch," said Dick. "Beside, there isn't any feed about here."

Somebody suggested that Bob Trotter had brought some hay and corn for his horses. Dick proposed that Julius should go for some. Julius proposed that Dick should go. Valentine offered to bring it, and brought it—some corn in a basket.

"Suke! Suke, Bossy! Suke, Bossy! Suke!" Dick yelled as though the cow had been two hundred feet off instead of ten. He held out the basket. She came forward, sniffed at the corn, threw up her lip and took a bite. Dick set the basket under her nose and hastened to put himself in milking position. But that was the end of it. He could not milk a drop.

"I can't get the hang of the thing," he said.

"Let me try," said Kit.

Dick gave way, and Kit pulled and squeezed and tugged and twisted, while the others shouted with laughter.

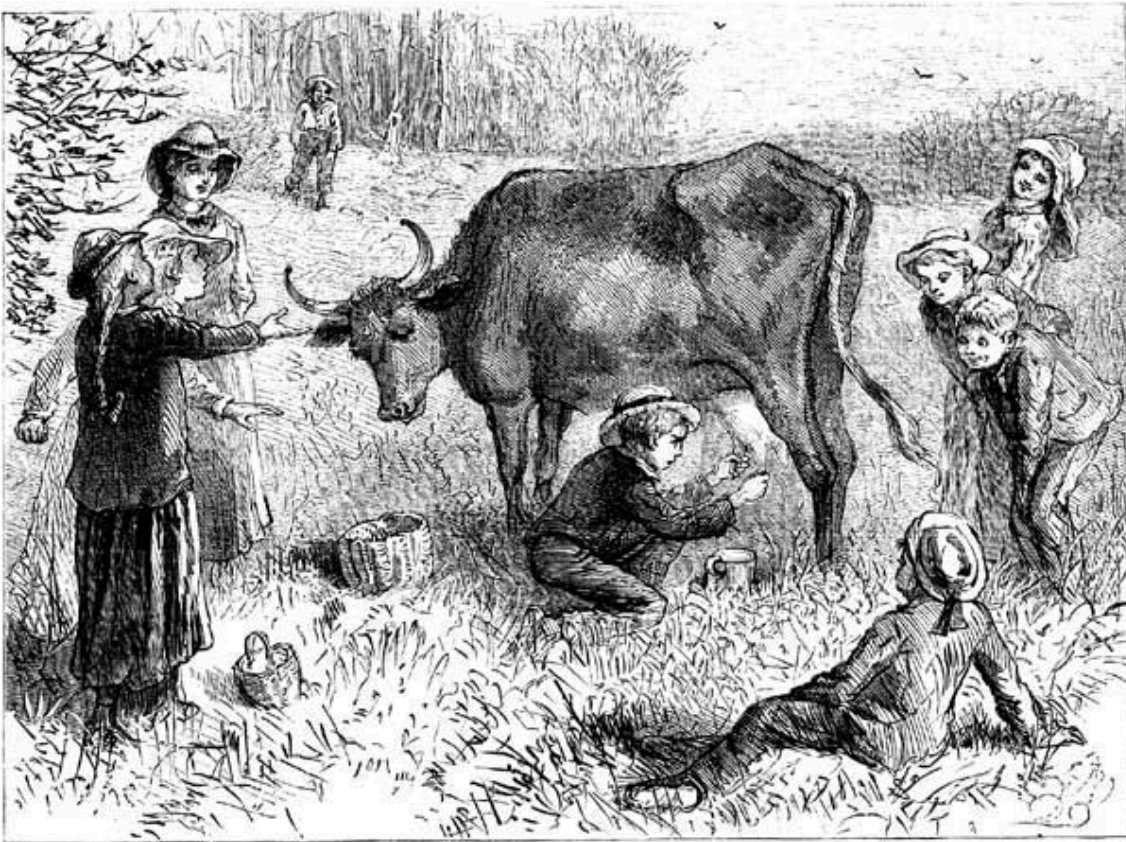

BELIEVE SHE'S GONE DRY,' SAID KIT.

"I believe she's gone dry," said Kit, very red in the face. At this the laughers laughed anew.

"Some of you who are so good at laughing had better try."

Kit set the cup on a stump and retired.

Sarah Ketchum tried to persuade everybody else to try, but the other boys were afraid of failure and the girls were afraid of the cow. Sarah said if somebody would hold the animal's head so that it couldn't hook, she'd milk—she knew she could. But nobody offered to take the cow by the horns; so everything came to a stand-still except Sarah's talking and the cow's eating. Then Bob Trotter came in sight, all his pockets standing out with nuts. They called him. Sarah Ketchum explained the situation and asked him if he could milk.

"I do the milkin' at 'ome," Bob replied.

"Wont you please milk this cow for us? We don't know how, and we want the milk for dinner."

There came a comical look into Bob's face, but he said nothing. The eight knew what his thoughts must be.

"We oughtn't to have said that you couldn't have any of our lunch," said Sarah Ketchum.

"We didn't really mean it," said Clara. "When lunch-time came we would have given you lots of good things."

"That's so," said Dick. "Sarah told us an hour ago that she meant to give you her snow-ball cake because she felt compuncted."

By this time Bob had approached the cow. He spoke some kind words close to her broad ear, and gently stroked her back and flanks. Then he set to work in the proper way, forcing the milk in streams into the cup, the boys watching with admiration Bob's ease and expertness, Dick wondering why he couldn't do what seemed so easy. In a few seconds the cup was filled.

"Now, what're you going to do?" said Bob. "This wont be a taste around."

"You might milk into our hats," said Julius.

"I've got a thimble in my pocket," said Sarah Ketchum.

"Do stop your nonsense," said Constance; "it's a very serious question—a life and death matter. We're a company of Crusoes."

But the boys couldn't stop their nonsense immediately. Dick remarked that if the cow had not licked out the jelly-bowl and then kicked it to pieces it might have been utilized. Then some one remembered a tin water-pail at the wagon. This was brought, and Bob soon had it two-thirds filled with milk. Then the question arose as to how they were all to be served with just that quart-cup and two spoons. They were to take turns, two eating at a time.

"I don't want to eat with Jule," Dick said. "He eats too fast."

The young people paired off, leaving out Bob. Then they all looked at him in a shame-faced, apologetic way.

"You needn't mind me," said Bob, interpreting their glances. "I don't want to heat with none of you. I've got some wittals down to the wagon."

"Why, what have you got?" said Sarah Ketchum. She felt cheap, and so did the others.

"Some boiled heggs and some happles and some raw turnups," said Bob.

Eight mouths watered at this catalogue. Sarah [Page 519] Ketchum whispered:

"For a generous slice of turnip, I'd lay me down and die."

"I don't keer for nothing but a hegg and a happle, myself," said Bob. "May be you folks would heat the hother things. There's a good lot of happles."

The eight protested that they could do with the milk and bread, but urged the milk on Bob.

"No, I thank you," he said.

"He's mad at us yet," Mat whispered.

"Look here," said Sarah Ketchum to Bob, "if you don't eat some of this milk, none of us will. We'll give it to the cow."

"No, we won't do that," Julius said: "we'll hold you and make you drink it. If you have more apples than you wish, we'll be glad of some; but we aren't going to take them unless you'll take your share of the milk."

"And we'll get mad at you again," said Clara.

"I'll drink hall the milk necessary to a make-hup," said Bob.

When the lunch was eaten, Mat said she didn't think they ought to have milked the cow. The folks would be so disappointed when they came to milk her at night. May be a lot of poor children were depending on the milking for their supper. Val, too, showed that his conscience was disturbed.

"You needn't worry," said Dick. "They'll get this milk back from the lunch she stole."

"But they couldn't help her stealing."

"And I couldn't help milking her," said Dick.

At this there was a burst of laughter. Then Mat wrote on a scrap of paper: **"This cow has been milked to save some boys and girls from starvation. The owner can get pay for the milk by calling at Mr. Snead's, Poplar street, Budville."**

"Who'll tie it on her tail?" asked Mat.

"I will," said Val, promptly, glad to ease his conscience.

And this he did with a piece of blue ribbon from Mat Snead's hat.



MRS. PETER PIPER'S PICKLES.

BY E. MÜLLER.



"HERE'S nothing in that bush," said one old crow to another old crow, as they flew slowly along the beach.

"No, nothing worth looking at," answered the other old crow, and then they alighted on a dead tree and complained that the egg season was over.

That was because they were fond of sandpipers' eggs, and there were none in that bush. No eggs were there, to be sure, but there sat Mrs. Peter Sandpiper, talking to two fine young sandpipers, just hatched.

"Nothing worth looking at!" said she, indignantly. "Well, anything but a crow would have more sense! Nothing in this bush, indeed! Pe-tweet, pe-tweet!"

And truly she might well be angry at any one snubbing those young ones of hers. Their eyes were so bright, their legs were so slim, and their beaks so sharp that it was delightful to see them. And they turned out their toes so gracefully that, the first time they went to the sea to bathe, everyone said Mrs. Peter Sandpiper had reason to be proud of her children. But just as soon as they could run they got into all sorts of troubles, and [Page 520] vexed Mrs. Sandpiper out of her wits.

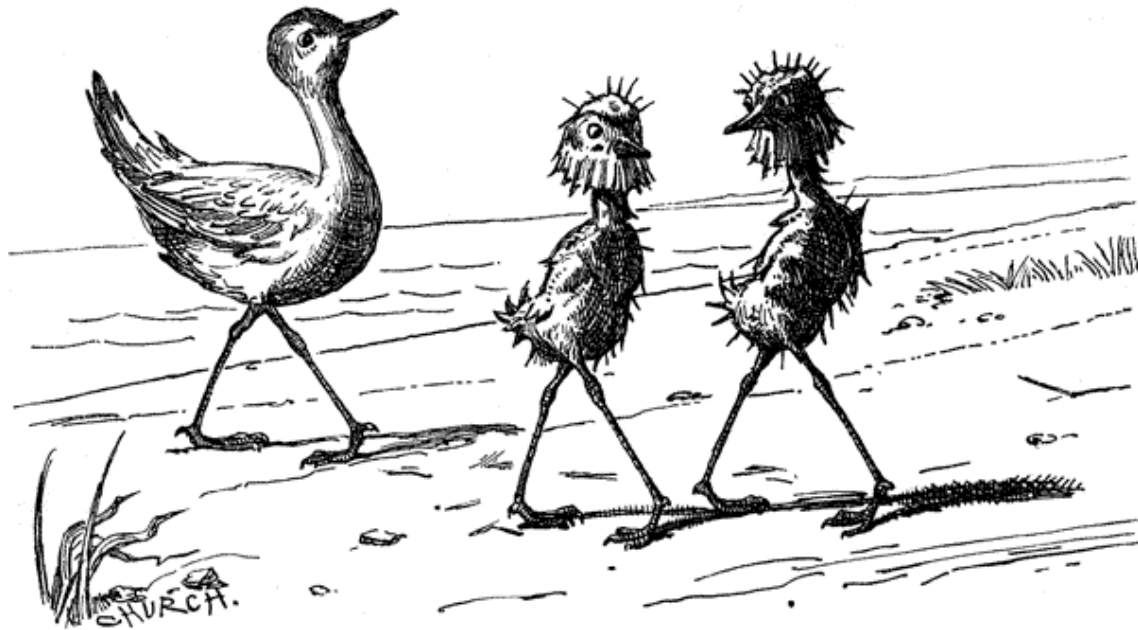

"THEY TURNED OUT THEIR TOES SO GRACEFULLY."

"Such a pair of young pickles I never hatched before!" said she to Mrs. Kingfisher, who came to gossip one day.

"Well, well, my dear," said Mrs. Kingfisher, "boys will be boys; by the time they are grown up they will be all right. Now, my dear Pinlegs was just such—"

But Mrs. Sandpiper had to fly off, to see what Pipsy Sandpiper was doing, and keep Nipsy Sandpiper from swallowing a June beetle twice too big for him. They were great trials. They were always eating the wrong kind of bugs, and having indigestion and headaches. They were forever getting their legs tangled up in long wet grass, and screaming for Mrs. Peter Sandpiper to come help them out, and at night they chirped in their sleep and disturbed Mrs. Sandpiper dreadfully by kicking each other. At last she said she could stand it no longer; they must take care



TANGLED IN THE LONG GRASS

of themselves. So she cried "Pe-tweet, good-by," and then she flew away, leaving Pipsy and Nipsy alone by the sea to take care of themselves.

[Page 521]

It was quite a trouble at first, for Mamma Sandpiper had always helped them to bugs and worms, one apiece, turn about, so all was fair. But now Pipsy always wanted the best of everything, and Nipsy, being good tempered, had to eat what his brother left. One day bugs were very scarce, and both little Sandpipers were so hungry that they could have eaten a whole starfish—if he had come out of his shelter. Suddenly Nipsy, who was a trifle near sighted, said he saw a large beetle coming along the beach. They ran quickly to meet it. But what in the world was it! It had legs; oh, such legs! They were larger than Pipsy's and Nipsy's put together. Its back was like a huge shell, and its eyes were dreadful. The little sandpipers looked at each other in terror.

But a mild little voice from the creature relieved [Page 522] them.

"I beg your pardon," said he. "Let me introduce myself. C. Crab, Esq., of Oyster Bay."

"Oh, ah! Indeed!" said Pipsy. "Glad to know you, I'm sure."

"I think I must have lost my way," said C. Crab, Esq. "Could you oblige me by telling me if you see any boys near?"

"Any boys?" said Pipsy and Nipsy, looking at each other. "Never saw one in my life. What do they look like? Have they many legs? Are they fat? Are they good to eat?" asked both the hungry little sandpipers.

"They are creatures," said the crab, with a groan,— "creatures a thousand times larger than we are. They have strings. They tie up legs and pull. They throw stones. If you ever see a boy, run for your life."

"Good gracious me!" cried both the little sandpipers. "How very dreadful!"

But there were no boys in sight; so C. Crab grew sociable, and offered to show them a place where bugs were plenty. "Just get on my back," said he, "and I'll have you there in no time."



"OH, MY! HE'S GOING BACKWARDS!"

So they got on his back. It was very wet and slippery, but they held on with their toes, while C. Crab gave himself a heave and started.

"Oh, my!" exclaimed Nipsy. "He's going backward!"

"He actually is!" cried Pipsy. "At this rate we'll get there day before yesterday, wont we?"

"Surely," said Nipsy. "How very horrid of him when we are so hungry! What a slow coach!"

"Let's jump off quick, or he'll take us clear into last week!" cried the silly sandpipers, and then they skipped off and ran down the beach in the opposite direction. C. Crab called to them, but it was no use, so he went on his way. But as for the sandpipers, they went on getting into trouble. The day was hot, and after they had run some distance, they stepped into the water to cool off. Nipsy stepped in first, but the water was up to his breast and it frightened him, so he stepped out again.

"Pooh!" said Pipsy. "You're afraid, YOU are! Look at me!"

Then he jumped in, and only his head stuck out.

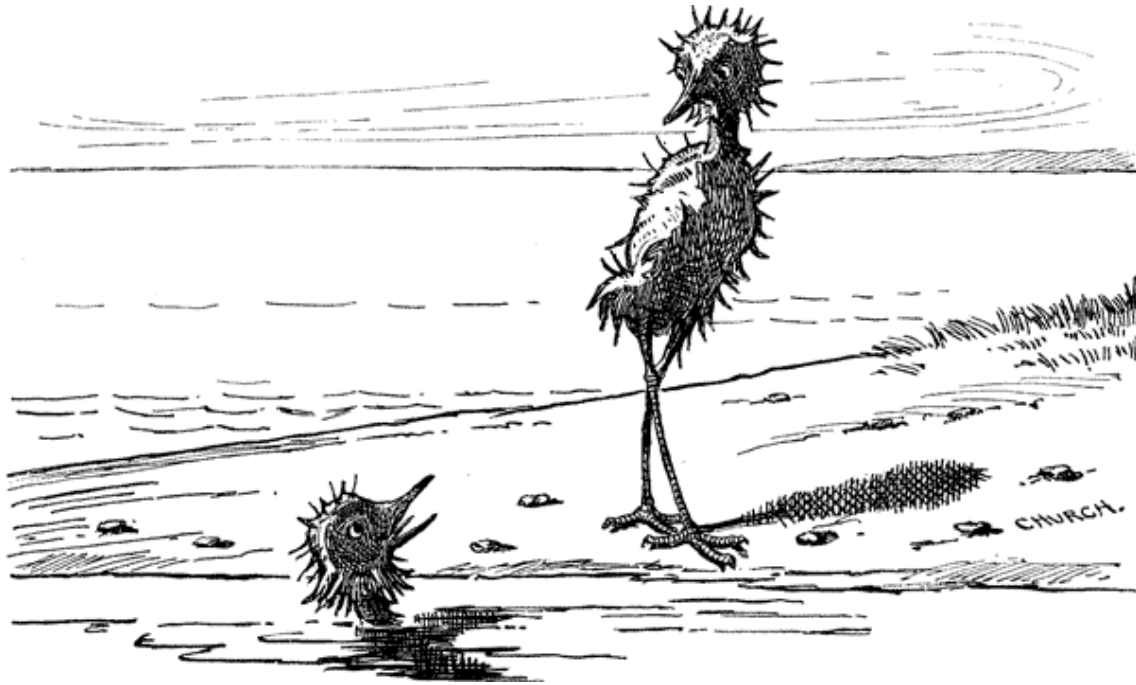

"THIS IS TWICE AS DEEP AS YOU WERE IN."

"This is twice as deep as you were in!" he cried, turning up his bill, and rolling his eyes.

"You're sitting down, *you* are!" cried Nipsy, in scorn.

"I'm not," said Pipsy.

"You are. I can see your toes all doubled up, even if the water *is* muddy," said Nipsy, and rushed at him to punish him for bragging.

They both rolled under the water, and then out on the shore, dripping wet and very angry with each other.

Pipsy went home to the old bush and was very miserable. He wanted something to eat, and did not know where to find anything. Nipsy went high up the beach, and found a lot of young hedge-crickets. But he did not half enjoy them. They were fat and smooth, and he was hungry, but crickets had no flavor without Pipsy to help eat them. But he was angry at him yet.

"He must come to me," he said, sternly, to the cricket he was eating.

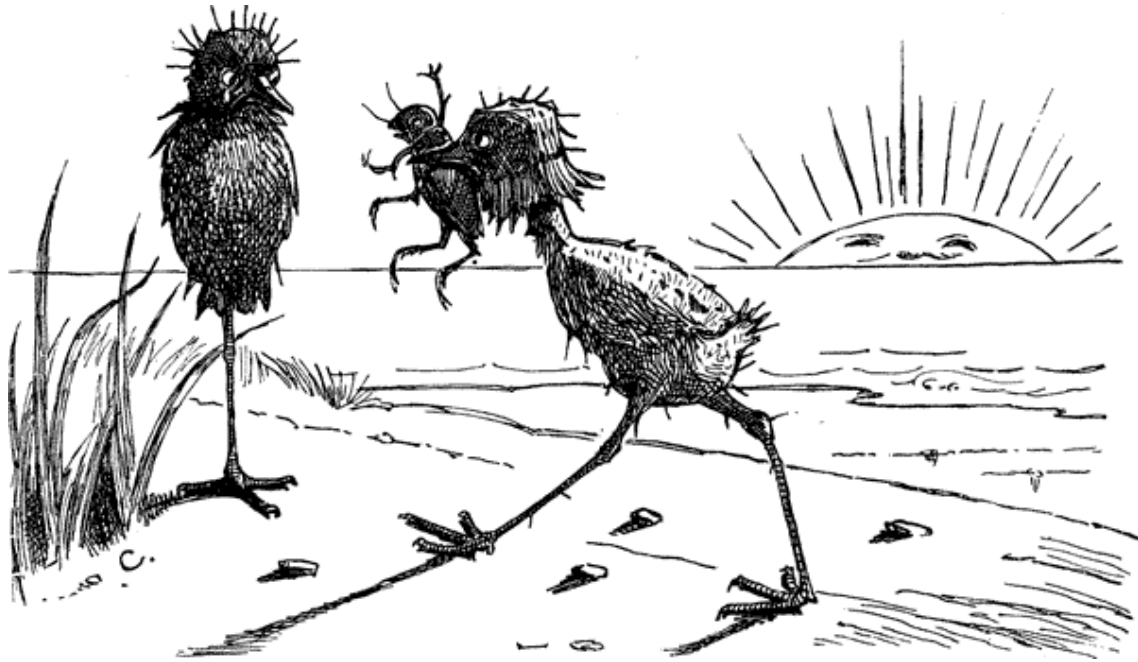

"THERE, IN THE TWILIGHT, HE SAW A LONELY FIGURE STANDING ON ONE LEG."

The cricket said nothing, being half-way down his throat, and pretty soon Nipsy could stand his feelings no longer. Catching up the largest, smoothest, softest cricket, he ran down to the shore as fast as his legs could carry him. There, in the twilight, he saw a lonely figure standing on one leg.

"Pipsy!" he cried.

"Nipsy!" cried Pipsy.

And they flew to each other.

"Here's a glorious fat cricket for you."

"Forgive me, Nipsy," said his brother.

And then they were happy.



UNDER THE LILACS.

BY LOUISA M. ALCOTT.

CHAPTER XIV.

SOMEBODY GETS LOST.

Putting all care behind them, the young folks ran down the hill, with a very lively dog gamboling beside them, and took a delightfully tantalizing survey of the external charms of the big tent. But people were beginning to go in, and it was impossible to delay when they came round to the entrance.

Ben felt that now "his foot was on his native heath," and the superb air of indifference with which he threw down his dollar at the ticket-office, carelessly swept up the change, and strolled into the tent with his hands in his pockets, was so impressive that even big Sam repressed his excitement and meekly followed their leader, as he led them from cage to cage, doing the honors as if he owned the whole concern. Bab held tight to the tail of his jacket, staring about her with round eyes, and listening with little gasps of astonishment or delight to the roaring of lions, the snarling of tigers, the chatter of the monkeys, the groaning of camels, and the music of the very brass band shut up in a red bin.

Five elephants were tossing their hay about in the middle of the menagerie, and Billy's legs shook under him as he looked up at the big beasts whose long noses and small, sagacious eyes filled him with awe. Sam was so tickled by the droll monkeys that they left him before the cage and went on to see the zebra, "striped just like Ma's muslin gown," Bab declared. But the next minute she forgot all about him in her raptures over the ponies and their tiny colts, especially one mite of a thing who lay asleep on the hay, such a miniature copy of its little mouse-colored mamma that one could hardly believe it was alive.

"Oh, Ben, I *must* feel of it!—the cunning baby horse!" and down went Bab inside the rope to pat and admire the pretty creature, while its mother smelt suspiciously at the brown hat, and baby lazily opened one eye to see what was going on.

"Come out of that, it isn't allowed!" commanded Ben, longing to do the same thing, but mindful of the proprieties and his own dignity.

Bab reluctantly tore herself away to find consolation in watching the young lions, who looked so like big puppies, and the tigers washing their faces just as puss did.

"If I stroked 'em, wouldn't they purr?" she asked, bent on enjoying herself, while Ben held her skirts lest she should try the experiment.

"You'd better not go to patting them, or you'll get your hands clawed up. Tigers do purr like fun when they are happy, but these fellers never are, and you'll only see 'em spit and snarl," said Ben, leading the way to the humpy camels, who were peacefully chewing their cud and longing for the desert, with a dreamy, far-away look in their mournful eyes.

Here, leaning on the rope, and scientifically chewing a straw while he talked, Ben played showman to his heart's content till the neigh of a horse from the circus tent beyond reminded him of the joys to come.

"We'd better hurry along and get good seats before folks begin to crowd. I want to sit near the curtain and see if any of Smithers's lot are 'round."

"I aint going way off there; you can't see half so well, and that big drum makes such a noise you can't hear yourself think," said Sam, who had rejoined them.

So they settled in good places where they could see and hear all that went on in the ring and still catch glimpses of white horses, bright colors, and the glitter of helmets beyond the dingy red curtains. Ben treated Bab to peanuts and pop-corn like an indulgent parent, and she murmured protestations of undying gratitude with her mouth full, as she sat blissfully between him and the congenial Billy.

Sancho, meantime, had been much excited by the familiar sights and sounds, and now was greatly exercised in his doggish mind at the unusual proceeding of his master; for he was sure that they ought to be within there, putting on their costumes, ready to take their turn. He looked anxiously at Ben, sniffed disdainfully at the strap as if to remind him that a scarlet ribbon ought to take its place, and poked peanut shells about with his paw as if searching for the letters with which to spell his famous name.

"I know, old boy, I know; but it can't be done. We've quit the business and must just look on. No larks for us this time, Sanch, so keep quiet and behave," whispered Ben, tucking the dog away under the seat with a sympathetic cuddle of the curly head that peeped out from between his feet.

"He wants to go and cut up, don't he?" said Billy, "and so do you, I guess. Wish you were going to. Wouldn't it be fun to see Ben showing off in there?"

"I'd be afraid to have him go up on a pile of [Page 524] elephants and jump through hoops like these folks," answered Bab, poring over her pictured play-bill with unabated relish.

"Done it a hundred times, and I'd just like to show you what I can do. They don't seem to have any boys in this lot; shouldn't wonder if they'd take me if I asked 'em," said Ben, moving uneasily on his seat and casting wistful glances toward the inner tent where he knew he would feel more at home than in his present place.



"AT THE CIRCUS"

"I heard some men say that it's against the law to have small boys now; it's so dangerous and not good for them, this kind of thing. If that's so, you're done for. Ben," observed Sam, with his most grown-up air, remembering Ben's remarks on "fat boys."

"Don't believe a word of it, and Sanch and I could go this minute and get taken on, I'll bet. We are a valuable couple, and I could prove it if I chose to," began Ben, getting excited and boastful.

"Oh, see, they're coming!—gold carriages and lovely horses, and flags and elephants, and everything!" cried Bab, giving a clutch at Ben's arm as the opening procession appeared headed by the band, tooting and banging till their faces were as red as their uniforms.

Round and round they went till every one had seen their fill, then the riders alone were left caracoling about the ring with feathers flying, horses prancing, and performers looking as tired and indifferent as if they would all like to go to sleep then and there.

"How splendid!" sighed Bab, as they went dashing out, to tumble off almost before the horses stopped.

"That's nothing! You wait till you see the bare-back riding and the 'acrobatic exercises,'" said Ben, quoting from the play-bill, with the air of one who knew all about the feats to come, and could never be surprised any more.

"What are 'crowbackic exercises?'" asked Billy, thirsting for information.

"Leaping and climbing and tumbling; you'll see—George! what a stunning horse!" and Ben forgot everything else to feast his eyes on the handsome creature who now came pacing in to dance, upset and replace chairs, kneel, bow, and perform many wonderful or graceful feats, ending with a swift gallop while the rider sat in a chair on its back fanning himself, with his legs crossed, as comfortably as you please.

"That, now, is something like," and Ben's eyes shone with admiration and envy as the pair vanished, and the pink and silver acrobats came leaping into the ring.

The boys were especially interested in this part, and well they might be; for strength and agility are manly attributes which lads appreciate, and these lively

fellows flew about like India rubber balls, each trying to outdo the other, till the leader of the acrobats capped the climax by turning a double somersault over five elephants standing side by side.

"There, sir, how's that for a jump?" asked Ben, rubbing his hands with satisfaction as his friends clapped till their palms tingled.

"We'll rig up a spring-board and try it," said Billy, fired with emulation.

"Where'll you get your elephants?" asked Sam,^[Page 525] scornfully, for gymnastics were not in his line.

"You'll do for one," retorted Ben, and Billy and Bab joined in his laugh so heartily that a rough-looking man who sat behind them, hearing all they said, pronounced them a "jolly set," and kept his eye on Sancho, who now showed signs of insubordination.

"Hullo, that wasn't on the bill!" cried Ben, as a parti-colored clown came in, followed by half a dozen dogs.

"I'm so glad; now Sancho will like it. There's a poodle that might be his ownty donty brother—the one with the blue ribbon," said Bab, beaming with delight as the dogs took their seats in the chairs arranged for them.

Sancho did like it only too well, for he scrambled out from under the seat in a great hurry to go and greet his friends, and, being sharply checked, set up and begged so piteously that Ben found it very hard to refuse and order him down. He subsided for a moment, but when the black spaniel, who acted the canine clown, did something funny and was applauded, Sancho made a dart as if bent on leaping into the ring to outdo his rival, and Ben was forced to box his ears and put his feet on the poor beast, fearing he would be ordered out if he made any disturbance.

Too well trained to rebel again, Sancho lay meditating on his wrongs till the dog act was over, carefully abstaining from any further sign of interest in their tricks, and only giving a sidelong glance at the two little poodles who came out of a basket to run up and down stairs on their fore paws, dance jigs on their hind legs, and play various pretty pranks to the great delight of all the children in the audience. If ever a dog expressed by look and attitude, "Pooh! I could do much better than that, and astonish you all, if I was only allowed to," that dog was

Sancho, as he curled himself up and affected to turn his back on an unappreciative world.

"It's too bad, when he knows more than all those chaps put together. I'd give anything if I could show him off as I used to. Folks always liked it, and I was ever so proud of him. He's mad now because I had to cuff him, and wont take any notice of me till I make up," said Ben, regretfully eyeing his offended friend, but not daring to beg pardon yet.

More riding followed, and Bab was kept in a breathless state by the marvelous agility and skill of the gauzy lady who drove four horses at once, leaped through hoops, over banners and bars, sprang off and on at full speed, and seemed to enjoy it all so much it was impossible to believe that there could be any danger or exertion in it.

Then two girls flew about on the trapeze, and walked on a tight rope, causing Bab to feel that she had at last found her sphere, for, young as she was, her mother often said:

"I really don't know what this child is fit for, except mischief, like a monkey."

"I'll fix the clothes-line when I get home, and show Ma how nice it is. Then, may be, she'll let me wear red and gold trousers, and climb round like these girls," thought the busy little brain, much excited by all it saw on that memorable day.

Nothing short of a pyramid of elephants with a glittering gentleman in a turban and top boots on the summit would have made her forget this new and charming plan. But that astonishing spectacle and the prospect of a cage of Bengal tigers with a man among them, in imminent danger of being eaten before her eyes, entirely absorbed her thoughts till, just as the big animals went lumbering out, a peal of thunder caused considerable commotion in the audience. Men on the highest seats popped their heads through the openings in the tent-cover and reported that a heavy shower was coming up. Anxious mothers began to collect their flocks of children as hens do their chickens at sunset; timid people told cheerful stories of tents blown over in gales, cages upset and wild beasts let loose. Many left in haste, and the performers hurried to finish as soon as possible.

"I'm going now before the crowd comes, so I can get a lift home. I see two or three folks I know, so I'm off;" and, climbing hastily down, Sam vanished without further ceremony.

"Better wait till the shower is over. We can go and see the animals again, and get home all dry, just as well as not," observed Ben, encouragingly, as Billy looked anxiously at the billowing canvas over his head, the swaying posts before him, and heard the quick patter of drops outside, not to mention the melancholy roar of the lion which sounded rather awful through the sudden gloom which filled the strange place.

"I wouldn't miss the tigers for anything. See, they are pulling in the cart now, and the shiny man is all ready with his gun. Will he shoot any of them, Ben?" asked Bab, nestling nearer with a little shiver of apprehension, for the sharp crack of a rifle startled her more than the loudest thunder-clap she ever heard.

"Bless you, no, child; it's only powder to make a noise and scare 'em. I wouldn't like to be in his place, though; father says you can never trust tigers as you can lions, no matter how tame they are. Sly fellers, like cats, and when they scratch it's no joke, I tell you," answered Ben, with a knowing wag of the head, as the sides of the cage rattled down, and the poor, fierce creatures were seen leaping and snarling as if they resented this [Page 526] display of their captivity.

Bab curled up her feet and winked fast with excitement as she watched the "shiny man" fondle the great cats, lie down among them, pull open their red mouths, and make them leap over him or crouch at his feet as he snapped the long whip. When he fired the gun and they all fell as if dead, she with difficulty suppressed a small scream and clapped her hands over her ears; but poor Billy never minded it a bit, for he was pale and quaking with the fear of "heaven's artillery" thundering over head, and as a bright flash of lightning seemed to run down the tall tent-poles he hid his eyes and wished with all his heart that he was safe with mother.

"'Fraid of thunder, Bill?" asked Ben, trying to speak stoutly, while a sense of his own responsibilities began to worry him, for how was Bab to be got home in such a pouring rain.

"It makes me sick; always did. Wish I hadn't come," sighed Billy, feeling, all too late, that lemonade and "lozengers" were not the fittest food for man, or a

stifling tent the best place to be in on a hot July day, especially in a thunderstorm.

"I didn't ask you to come; *you* asked *me*; so it isn't my fault," said Ben, rather gruffly, as people crowded by without pausing to hear the comic song the clown was singing in spite of the confusion.

"Oh, I'm *so* tired," groaned Bab, getting up with a long stretch of arms and legs.

"You'll be tireder before you get home, I guess. Nobody asked *you* to come, anyway;" and Ben gazed dolefully round him wishing he could see a familiar face or find a wiser head than his own to help him out of the scrape he was in.

"I said I wouldn't be a bother, and I wont. I'll walk right home this minute, I aint afraid of thunder, and the rain wont hurt these old clothes. Come along," cried Bab, bravely, bent on keeping her word, though it looked much harder after the fun was all over than before.

"My head aches like fury. Don't I wish old Jack was here to take me back," said Billy, following his companions in misfortune with sudden energy, as a louder peal than before rolled overhead.

"You might as well wish for Lita and the covered wagon while you are about it, then we could all ride," answered Ben, leading the way to the outer tent, where many people were lingering in hopes of fair weather.

"Why, Billy Barton, how in the world did you get here?" cried a surprised voice, as the crook of a cane caught the boy by the collar and jerked him face to face with a young farmer, who was pushing along followed by his wife and two or three children.

"Oh, Uncle Eben, I'm so glad you found me! I walked over, and it's raining, and I don't feel well. Let me go with you, can't I?" asked Billy, casting himself and all his woes upon the strong arm that had laid hold of him.

"Don't see what your mother was about to let you come so far alone, and you just over scarlet fever. We are as full as ever we can be, but we'll tuck you in somehow," said the pleasant-faced woman, bundling up her baby, and bidding the two little lads "keep close to father."

"I didn't come alone. Sam got a ride, and can't you tuck Ben and Bab in too? They aint very big, either of them," whispered Billy, anxious to serve his friends now that he was provided for himself.

"Can't do it, anyway. Got to pick up mother at the corner, and that will be all I can carry. It's lifting a little; hurry along, Lizzie, and let us get out of this as quick as possible," said Uncle Eben, impatiently; for going to a circus with a young family is not an easy task, as every one knows who has ever tried it.

"Ben, I'm real sorry there isn't room for you. I'll tell Bab's mother where she is, and may be some one will come for you," said Billy, hurriedly, as he tore himself away, feeling rather mean to desert the others, though he could be of no use.

"Cut away and don't mind us. I'm all right, and Bab must do the best she can," was all Ben had time to answer before his comrade was hustled away by the crowd pressing round the entrance with much clashing of umbrellas and scrambling of boys and men, who rather enjoyed the flurry.

"No use for us to get knocked about in that scrimmage. We'll wait a minute and then go out easy. It's a regular rouser, and you'll be as wet as a sop before we get home. Hope you'll like that?" added Ben, looking out at the heavy rain pouring down as if it never meant to stop.

"Don't care a bit," said Bab, swinging on one of the ropes with a happy-go-lucky air, for her spirits were not extinguished yet, and she was bound to enjoy this exciting holiday to the very end. "I like circuses so much! I wish I lived here all the time, and slept in a wagon, as you did, and had these dear little colties to play with."

"It wouldn't be fun if you didn't have any folks to take care of you," began Ben, thoughtfully looking about the familiar place where the men were now feeding the animals, setting their refreshment tables, or lounging on the hay to get such rest as they could before the evening entertainment. Suddenly he started, gave a long look, then turned to Bab, and thrusting Sancho's strap into her hand, said, hastily: "I see a fellow I used to know.^[Page 527] May be he can tell me something about father. Don't you stir till I come back."

Then he was off like a shot, and Bab saw him run after a man with a bucket who had been watering the zebra. Sancho tried to follow, but was checked with an

impatient:

"No, you can't go! What a plague you are, tagging around when people don't want you."

Sancho might have answered, "So are you," but, being a gentlemanly dog, he sat down with a resigned expression to watch the little colts, who were now awake and seemed ready for a game of bo-peep behind their mammas. Bab enjoyed their funny little frisks so much that she tied the wearisome strap to a post and crept under the rope to pet the tiny mouse-colored one who came and talked to her with baby whinneys and confiding glances of its soft, dark eyes.

Oh, luckless Bab! why did you turn your back? Oh, too accomplished Sancho! why did you neatly untie that knot and trot away to confer with the disreputable bull-dog who stood in the entrance beckoning with friendly wavings of an abbreviated tail? Oh, much afflicted Ben! why did you delay till it was too late to save your pet from the rough man who set his foot upon the trailing strap and led poor Sanch quickly out of sight among the crowd.

"It *was* Bascum, but he didn't know anything. Why, where's Sanch?" said Ben, returning.

A breathless voice made Bab turn to see Ben looking about him with as much alarm in his hot face as if the dog had been a two years' child.

"I tied him—he's here somewhere—with the ponies," stammered Bab, in sudden dismay, for no sign of a dog appeared as her eyes roved wildly to and fro.

Ben whistled, called and searched in vain, till one of the lounging men said, lazily:

"If you are looking after the big poodle you'd better go outside; I saw him trotting off with another dog."

Away rushed Ben, with Bab following, regardless of the rain, for both felt that a great misfortune had befallen them. But, long before this, Sancho had vanished, and no one minded his indignant howls as he was driven off in a covered cart.

"If he is lost I'll never forgive you; never, never, never!" and Ben found it impossible to resist giving Bab several hard shakes which made her yellow braids fly up and down like pump handles.

"I'm dreadful sorry. He'll come back—you said he always did," pleaded Bab, quite crushed by her own afflictions, and rather scared to see Ben look so fierce, for he seldom lost his temper or was rough with the little girls.

"If he doesn't come back, don't you speak to me for a year. Now, I'm going home." And, feeling that words were powerless to express his emotions, Ben walked away, looking as grim as a small boy could.

A more unhappy little lass is seldom to be found than Bab was, as she pattered after him, splashing recklessly through the puddles, and getting as wet and muddy as possible, as a sort of penance for her sins. For a mile or two she trudged stoutly along, while Ben marched before in solemn silence, which soon became both impressive and oppressive because so unusual, and such a proof of his deep displeasure. Penitent Bab longed for just one word, one sign of relenting; and when none came, she began to wonder how she could possibly bear it if he kept his dreadful threat and did not speak to her for a whole year.

But presently her own discomfort absorbed her, for her feet were wet and cold as well as very tired; pop-corn and peanuts were not particularly nourishing food, and hunger made her feel faint; excitement was a new thing, and now that it was over she longed to lie down and go to sleep; then the long walk with a circus at the end seemed a very different affair from the homeward trip with a distracted mother awaiting her. The shower had subsided into a dreary drizzle, a chilly east wind blew up, the hilly road seemed to lengthen before the weary feet, and the mute, blue flannel figure going on so fast with never a look or sound, added the last touch to Bab's remorseful anguish.

Wagons passed, but all were full, and no one offered a ride. Men and boys went by with rough jokes on the forlorn pair, for rain soon made them look like young tramps. But there was no brave Sancho to resent the impertinence, and this fact was sadly brought to both their minds by the appearance of a great Newfoundland dog who came trotting after a carriage. The good creature stopped to say a friendly word in his dumb fashion, looking up at Bab with benevolent eyes, and poking his nose into Ben's hand before he bounded away with his plummy tail curled over his back.

Ben started as the cold nose touched his fingers, gave the soft head a lingering pat, and watched the dog out of sight through a thicker mist than any the rain made. But Bab broke down; for the wistful look of the creature's eyes reminded

her of lost Sancho, and she sobbed quietly as she glanced back longing to see the dear old fellow jogging along in the rear.

Ben heard the piteous sound and took a sly peep over his shoulder, seeing such a mournful spectacle that he felt appeased, saying to himself as if to excuse his late sternness:

"She *is* a naughty girl, but I guess she is about sorry enough now. When we get to that sign-post [Page 528] I'll speak to her, only I won't forgive her till Sanch comes back."

But he was better than his word; for, just before the post was reached, Bab, blinded by tears, tripped over the root of a tree, and, rolling down the bank, landed in a bed of wet nettles. Ben had her out in a jiffy, and vainly tried to comfort her; but she was past any consolation he could offer, and roared dismally as she wrung her tingling hands, with great drops running over her cheeks almost as fast as the muddy little rills ran down the road.

"Oh dear, oh dear! I'm all stinged up, and I want my supper; and my feet ache, and I'm cold, and everything is *so* horrid!" wailed the poor child lying on the grass, such a miserable little wet bunch that the sternest parent would have melted at the sight.

"Don't cry so, Babby; I was real cross, and I'm sorry. I'll forgive you right away now, and never shake you any more," cried Ben, so full of pity for her tribulations that he forgot his own, like a generous little man.

"Shake me again, if you want to; I know I was very bad to tag and lose Sanch. I never will any more, and I'm so sorry, I don't know what to do," answered Bab, completely bowed down by this magnanimity.

"Never mind; you just wipe up your face and come along, and we'll tell Ma all about it, and she'll fix us as nice as can be. I shouldn't wonder if Sanch got home now before we did," said Ben, cheering himself as well as her by the fond hope.

"I don't believe *I* ever shall, I'm so tired my legs won't go, and the water in my boots makes them feel dreadfully. I wish that boy would wheel me a piece. Don't you s'pose he would?" asked Bab, wearily picking herself up as a tall lad trundling a barrow came out of a yard near by.

"Hullo, Joslyn!" said Ben, recognizing the boy as one of the "hill fellows" who come to town Saturday nights for play or business.

"Hullo, Brown," responded the other, arresting his squeaking progress with signs of surprise at the moist tableau before him.

"Where goin'?" asked Ben with masculine brevity.

"Got to carry this home, hang the old thing!"

"Where to?"

"Batchelor's, down yonder," and the boy pointed to a farm-house at the foot of the next hill.

"Goin' that way, take it right along."

"What for?" questioned the prudent youth, distrusting such unusual neighborliness.

"She's tired, wants a ride; I'll leave it all right, true as I live and breathe," explained Ben, half ashamed yet anxious to get his little responsibility home as soon as possible, for mishaps seemed to thicken.

"Ho, *you* couldn't cart her all that way! she's most as heavy as a bag of meal," jeered the taller lad, amused at the proposition.

"I'm stronger than most fellers of my size. Try, if I aint," and Ben squared off in such scientific style that Joslyn responded with sudden amiability:

"All right, let's see you do it."

Bab huddled into her new equipage without the least fear, and Ben trundled her off at a good pace, while the boy retired to the shelter of the barn to watch their progress, glad to be rid of an irksome errand.

At first, all went well, for the way was down hill, and the wheel squeaked briskly round and round; Bab smiled gratefully upon her bearer, and Ben "went in on his muscle with a will," as he expressed it. But presently the road grew sandy, began to ascend, and the load seemed to grow heavier with every step.

"I'll get out now. It's real nice, but I guess I *am* too heavy," said Bab, as the face before her got redder and redder, and the breath began to come in puffs.

"Sit still. He said I couldn't. I'm not going to give in with him looking on," panted Ben, and pushed gallantly up the rise, over the grassy lawn to the side gate of the Batchelors' door-yard, with his head down, teeth set, and every muscle of his slender body braced to the task.

"Did ever ye see the like of that now? Ah, ha!

'The streets were so wide, and the lanes were so narry,
He brought his wife home on a little wheelbarry,"

sung a voice with an accent which made Ben drop his load and push back his hat, to see Pat's red head looking over the fence.

To have his enemy behold him then and there was the last bitter drop in poor Ben's cup of humiliation. A shrill approving whistle from the hill was some comfort, however, and gave him spirit to help Bab out with composure, though his hands were blistered and he had hardly breath enough to issue the command:

"Go along home, and don't mind him."

"Nice childer, ye are, runnin' off this way, settin' the women disthracted, and me wastin' me time comin' after ye when I'd be milkin' airly so I'd get a bit of pleasure the day," grumbled Pat, coming up to untie the Duke, whose Roman nose Ben had already recognized, as well as the roomy chaise standing before the door.

"Did Billy tell you about us?" asked Bab, gladly following toward this welcome refuge.

"Faith he did, and the Squire sint me to fetch ye home quiet and aisy. When ye found me, I'd jist^[Page 529] stopped here to borry a light for me pipe. Up wid ye, b'y, and not be wastin' me time stramashin' afther a spalpeen that I'd like to lay me whip over," said Pat, gruffly, as Ben came along, having left the barrow in the shed.

"Don't you wish you could? You needn't wait for me; I'll come when I'm ready," answered Ben, dodging round the chaise, bound not to mind Pat, if he spent the night by the road-side in consequence.

"Bedad, and I wont then. It's lively ye are; but four legs is better than two, as ye'll find this night, me young mon!"

With that he whipped up and was off before Bab could say a word to persuade Ben to humble himself for the sake of a ride. She lamented and Pat chuckled, both forgetting what an agile monkey the boy was, and as neither looked back, they were unaware that Master Ben was hanging on behind among the straps and springs, making derisive grimaces at his unconscious foe through the little glass in the leathern back.

At the lodge gate Ben jumped down to run before with whoops of naughty satisfaction, which brought the anxious waiters to the door in a flock; so Pat could only shake his fist at the exulting little rascal as he drove away, leaving the wanderers to be welcomed as warmly as if they were a pair of model children.

Mrs. Moss had not been very much troubled after all; for Cy had told her that Bab went after Ben, and Billy had lately reported her safe arrival among them, so, mother-like, she fed, dried, and warmed the runaways, before she scolded them.

Even then, the lecture was a mild one, for when they tried to tell the adventures which to them seemed so exciting, not to say tragical, the effect astonished them immensely, as their audience went into gales of laughter, especially at the wheelbarrow episode, which Bab insisted on telling, with grateful minuteness, to Ben's confusion. Thorny shouted, and even tender-hearted Betty forgot her tears over the lost dog to join in the familiar melody when Bab mimicked Pat's quotation from Mother Goose.

"We must not laugh any more, or these naughty children will think they have done something very clever in running away," said Miss Celia, when the fun subsided, adding soberly, "I *am* displeased, but I will say nothing, for I think Ben is already punished enough."

"Guess I am," muttered Ben, with a choke in his voice as he glanced toward the empty mat where a dear curly bunch used to lie with a bright eye twinkling out of the middle of it.



CHAPTER XV.

BEN'S RIDE.

Great was the mourning for Sancho, because his talents and virtues made him universally admired and beloved. Miss Celia advertised, Thorny offered rewards, and even surly Pat kept a sharp look-out for poodle dogs when he went to market; but no Sancho or any trace of him appeared. Ben was inconsolable, and sternly said it served Bab right when the *dog-wood* poison affected both face and hands. Poor Bab thought so, too, and dared ask no sympathy from him, though Thorny eagerly prescribed plantain leaves, and Betty kept her supplied with an endless succession of them steeped in cream and pitying tears. This treatment was so successful that the patient soon took her place in society as well as ever, but for Ben's affliction there was no cure, and the boy really suffered in his spirits.

"I don't think it's fair that I should have so much trouble—first losing father and then Sanch. If it wasn't for Lita and Miss Celia, I don't believe I could stand it," he said, one day, in a fit of despair, about a week after the sad event.

"Oh, come now, don't give up so, old fellow. We'll find him if he's alive, and if he isn't I'll try and get you another as good," answered Thorny, with a friendly slap on the shoulder, as Ben sat disconsolately among the beans he had been^[Page 530] hoeing.

"As if there ever could be another half as good!" cried Ben, indignant at the idea; "or as if I'd ever try to fill his place with the best and biggest dog that ever wagged a tail! No, sir, there's only one Sanch in all the world, and if I can't have him I'll never have a dog again."

"Try some other sort of a pet, then. You may have any of mine you like. Have the peacocks; do now," urged Thorny, full of boyish sympathy and good-will.

"They are dreadful pretty, but I don't seem to care about 'em, thank you," replied the mourner.

"Have the rabbits, all of them," which was a handsome offer on Thorny's part, for there were a dozen at least.

"They don't love a fellow as a dog does; all they care for is stuff to eat and dirt to burrow in. I'm sick of rabbits." And well he might be, for he had had the charge of them ever since they came, and any boy who has ever kept bunnies knows what a care they are.

"So am I! Guess we'll have an auction and sell out. Would Jack be a comfort to you? If he will, you may have him. I'm so well now, I can walk, or ride anything," added Thorny, in a burst of generosity.

"Jack couldn't be with me always, as Sanch was, and I couldn't keep him if I had him."

Ben tried to be grateful, but nothing short of Lita would have healed his wounded heart, and she was not Thorny's to give, or he would probably have offered her to his afflicted friend.

"Well, no, you couldn't take Jack to bed with you, or keep him up in your room, and I'm afraid he would never learn to do anything clever. I do wish I had something you wanted, I'd so love to give it to you."

He spoke so heartily and was so kind that Ben looked up, feeling that he had given him one of the sweetest things in the world—friendship; he wanted to tell him so, but did not know how to do it, so caught up his hoe and fell to work, saying, in a tone Thorny understood better than words:

"You are real good to me—never mind, I wont worry about it; only it seems extra hard coming so soon after the other——"

He stopped there, and a bright drop fell on the bean leaves, to shine like dew till Ben saw clearly enough to bury it out of sight in a great hurry.

"By Jove! I'll find that dog, if he is out of the ground. Keep your spirits up, my lad, and we'll have the dear old fellow back yet."

With which cheering prophecy Thorny went off to rack his brains as to what could be done about the matter.

Half an hour afterward, the sound of a hand-organ in the avenue roused him from the brown study into which he had fallen as he lay on the newly mown grass of the lawn. Peeping over the wall, Thorny reconnoitered, and, finding the organ a good one, the man a pleasant-faced Italian, and the monkey a lively animal, he ordered them all in, as a delicate attention to Ben, for music and monkey together might suggest soothing memories of the past, and so be a comfort.

In they came by way of the Lodge, escorted by Bab and Betty, full of glee, for hand-organs were rare in those parts, and the children delighted in them. Smiling till his white teeth shone and his black eyes sparkled, the man played away while the monkey made his pathetic little bows, and picked up the pennies Thorny threw him.

"It is warm, and you look tired. Sit down and I'll get you some dinner," said the young master, pointing to the seat which now stood near the great gate.

With thanks in broken English the man gladly obeyed, and Ben begged to be allowed to make Jacko equally comfortable, explaining that he knew all about monkeys and what they liked. So the poor thing was freed from his cocked hat and uniform, fed with bread and milk, and allowed to curl himself up in the cool grass for a nap, looking so like a tired little old man in a fur coat that the children were never weary of watching him.

Meantime, Miss Celia had come out, and was talking Italian to Giacomo in a way that delighted his homesick heart. She had been to Naples, and could understand his longing for the lovely city of his birth, so they had a little chat in the language which is all music, and the good fellow was so grateful that he played for the children to dance till they were glad to stop, lingering afterward as if he hated to set out again upon his lonely, dusty walk.

"I'd rather like to tramp round with him for a week or so. Could make enough to live on as easy as not, if I only had Sanch to show off," said Ben, as he was coaxing Jacko into the suit which he detested.

"You go wid me, yes?" asked the man, nodding and smiling, well pleased at the prospect of company, for his quick eye and what the boys let fall in their talk showed him that Ben was not one of them.

"If I had my dog I'd love to," and with sad eagerness Ben told the tale of his loss, for the thought of it was never long out of his mind.

"I tink I see droll dog like he, way off in New York. He do leetle trick wid letter, and dance, and go on he head, and many tings to make laugh," said the man, when he had listened to a list of Sanch's beauties and accomplishments.

"Who had him?" asked Thorny, full of interest [Page 531] at once.

"A man I not know. Cross fellow what beat him when he do letters bad.

"Did he spell his name?" cried Ben, breathlessly.

"No, that for why man beat him. He name Generale, and he go spell Sancho all times, and cry when whip fall on him. Ha! yes! that name true one, not Generale?" and the man nodded, waved his hands and showed his teeth, almost as much excited as the boys.

"It's Sanch! let's go and get him, now, right off!" cried Ben, in a fever to be gone.

"A hundred miles away, and no clue but this man's story? We must wait a little, Ben, and be sure before we set out," said Miss Celia, ready to do almost anything, but not so certain as the boys. "What sort of a dog was it? A large, curly, white poodle, with a queer tail?" she asked of Giacomo.

"No, Signorina mia, he no curly, no wite, he black, smooth dog, littel tail, small, so," and the man held up one brown finger with a gesture which suggested a short, wagging tail.

"There, you see how mistaken we were. Dogs are often named Sancho, especially Spanish poodles, for the original Sancho was a Spaniard, you know. This dog is not ours, and I'm so sorry."

The boys faces had fallen dismally as their hope was destroyed; but Ben would not give up, for him there was and could be only one Sancho in the world, and his quick wits suggested an explanation which no one else thought of.

"It may be my dog—they color 'em as we used to paint over trick horses. I told you he was a valuable chap, and those that stole him hide him that way, else he'd be no use, don't you see, because we'd know him."

"But the black dog had no tail," began Thorny, longing to be convinced, but still doubtful.

Ben shivered as if the mere thought hurt him, as he said, in a grim tone:

"They might have cut Sanch's off."

"Oh, no! no! they mustn't, they wouldn't!"

"How could any one be so wicked?" cried Bab and Betty, horrified at the suggestion.

"You don't know what such fellows would do to make all safe, so they could use a dog to earn their living for 'em," said Ben, with mysterious significance, quite forgetting in his wrath that he had just proposed to get his own living in that way himself.

"He no your dog? Sorry I not find him for you. Addio, signorina! Grazia, signor! Buon giorno, buon giorno," and, kissing his hand, the Italian shouldered organ and monkey, ready to go.

Miss Celia detained him long enough to give him her address, and beg him to let her know if he met poor Sanch in any of his wanderings, for such itinerant showmen often cross each other's paths. Ben and Thorny walked to the school-corner with him, getting more exact information about the black dog and his owner, for they had no intention of giving it up so soon.

That very evening, Thorny wrote to a boy cousin in New York giving all the particulars of the case, and begging him to hunt up the man, investigate the dog, and see that the police made sure that everything was right. Much relieved by this performance, the boys waited anxiously for a reply, and when it came found little comfort in it. Cousin Horace had done his duty like a man, but regretted that he could only report a failure. The owner of the black poodle was a suspicious character, but told a straight story, how he had bought the dog from a stranger, and exhibited him with success till he was stolen. Knew nothing of his history and was very sorry to lose him, for he was a remarkably clever beast.

"I told my dog man to look about for him, but he says he has probably been killed, with ever so many more, so there is an end of it, and I call it a mean shame."

"Good for Horace! I told you he'd do it up thoroughly and see the end of it," said Thorny, as he read that paragraph in the deeply interesting letter.

"May be the end of *that* dog, but not of mine. I'll bet he ran away, and if it *was* Sanch he'll come home. You see if he doesn't," cried Ben, refusing to believe that all was over.

"A hundred miles off? Oh, he couldn't find you without help, smart as he is," answered Thorny, incredulously.

Ben looked discouraged, but Miss Celia cheered him up again by saying:

"Yes, he could. My father had a friend who kept a little dog in Paris, and the creature found her in Milan and died of fatigue next day. That was very wonderful, but true, and I've no doubt that if Sanch *is* alive he will come home. Let us hope so, and be happy while we wait."

"We will!" said the boys, and day after day looked for the wanderer's return, kept a bone ready in the old place if he should arrive at night, and shook his mat to keep it soft for his weary bones when he came. But weeks passed, and still no Sanch.

Something else happened, however, so absorbing that he was almost forgotten for a time, and Ben found a way to repay a part of all he owed his best friend.

Miss Celia went off for a ride one afternoon, and an hour afterward, as Ben sat in the porch reading,^[Page 532] Lita dashed into the yard with the reins dangling about her legs, the saddle turned round, and one side covered with black mud, showing that she had been down. For a minute, Ben's heart stood still, then he flung away his book, ran to the horse, and saw at once by her heaving flanks, dilated nostrils and wet coat, that she must have come a long way and at full speed.

"She has had a fall, but isn't hurt or frightened," thought the boy, as the pretty creature rubbed her nose against his shoulder, pawed the ground and champed her bit, as if she tried to tell him all about the disaster, whatever it was.

"Lita, where's Miss Celia?" he asked, looking straight into the intelligent eyes, which were troubled but not wild.

Lita threw up her head and neighed loud and clear as if she called her mistress, and turning, would have gone again if Ben had not caught the reins and held her.

"All right, we'll find her;" and, pulling off the broken saddle, kicking away his shoes, and ramming his hat firmly on, Ben was up like a flash, tingling all over with a sense of power as he felt the bare back between his knees, and caught the roll of Lita's eye as she looked round with an air of satisfaction.

"Hi, there! Mrs. Moss! Something has happened to Miss Celia, and I'm going to find her. Thorny is asleep; tell him easy, and I'll come back as soon as I can."

Then, giving Lita her head, he was off before the startled woman had time to do more than wring her hands and cry out:

"Go for the Squire! Oh, what shall we do?"

As if she knew exactly what was wanted of her, Lita went back the way she had come, as Ben could see by the fresh, irregular tracks that cut up the road where she had galloped for help. For a mile or more they went, then she paused at a pair of bars which were let down to allow the carts to pass into the wide hay-fields beyond. On she went again cantering across the new-mown turf toward a brook, across which she had evidently taken a leap before; for, on the further side, at a place where cattle went to drink, the mud showed signs of a fall.

"You were a fool to try there, but where is Miss Celia?" said Ben, who talked to animals as if they were people, and was understood much better than any one not used to their companionship would imagine.

Now Lita seemed at a loss, and put her head down as if she expected to find her mistress where she had left her, somewhere on the ground. Ben called, but there was no answer, and he rode slowly along the brook-side, looking far and wide with anxious eyes.

"May be she wasn't hurt, and has gone to that house to wait," thought the boy, pausing for a last survey of the great, sunny field, which had no place of shelter in it but one rock on the other side of the little stream. As his eye wandered over it, something dark seemed to blow out from behind it, as if the wind played in the folds of a skirt, or a human limb moved. Away went Lita, and in a moment Ben had found Miss Celia, lying in the shadow of the rock, so white and motionless he feared that she was dead. He leaped down, touched her, spoke to

her, and receiving no answer, rushed away to bring a little water in his leaky hat to sprinkle in her face, as he had seen them do when any of the riders got a fall in the circus, or fainted from exhaustion after they left the ring, where "do or die" was the motto all adopted.

In a minute, the blue eyes opened, and she recognized the anxious face bending over her, saying faintly, as she touched it:

"My good little Ben, I knew you'd find me—I sent Lita for you—I'm so hurt I couldn't come."

"Oh, where? What shall I do? Had I better run up to the house?" asked Ben, overjoyed to hear her speak, but much dismayed by her seeming helplessness, for he had seen bad falls, and had them, too.

"I feel bruised all over, and my arm is broken, I'm afraid. Lita tried not to hurt me. She slipped, and we went down. I came here into the shade, and the pain made me faint, I suppose. Call somebody, and get me home."

Then, she shut her eyes, and looked so white that Ben hurried away and burst upon old Mrs. Paine, placidly knitting at the end door, so suddenly that, as she afterward said, "it sca't her like a clap o' thunder."

"Aint a man nowheres around. All down in the big medder gettin' in hay," was her reply to Ben's breathless demand for "everybody to come and see to Miss Celia."

He turned to mount, for he had flung himself off before Lita stopped, but the old lady caught his jacket and asked half a dozen questions in a breath.



BEN AND LITA AT THE BROOK.

"Who's your folks? What's broke? How'd she fall? Where is she? Why didn't she come right here? Is it a sunstroke?"

As fast as words could tumble out of his mouth Ben answered, and then tried to free himself, but the old lady held on while she gave her directions, expressed her sympathy, and offered her hospitality with incoherent warmth.

"Sakes alive! poor dear! Fetch her right in. Liddy, get out the camphire, and Melissy, you haul down a bed to lay her on. Falls is dretful uncert'in things; shouldn't wonder if her back was [Page 533] broke. Father's down yender, and he and Bijah will see to her. You go call 'em, and I'll blow the horn to start 'em up. Tell her we'll be pleased to see her, and it wont make a mite of trouble."

Ben heard no more, for as Mrs. Paine turned to take down the tin horn he was up and away.

Several long and dismal toots sent Lita galloping through the grassy path as the sound of the trumpet excites a war-horse, and "father and Bijah," alarmed by the signal at that hour, leaned on their rakes to survey with wonder the distracted-looking little horseman approaching like a whirlwind.

"Guess likely grandpa's had 'nother stroke. Told 'em to send over soon's ever it come," said the farmer calmly.

"Shouldn't wonder ef suthing was afire some'r's," conjectured the hired man, surveying the horizon for a cloud of smoke.

Instead of advancing to meet the messenger, both stood like statues in blue overalls and red flannel shirts, till the boy arrived and told his tale.

"Sho, that's bad," said the farmer, anxiously.

"That brook always was the darndest place," added Bijah, then both men bestirred themselves helpfully, the former hurrying to Miss Celia while the latter brought up the cart and made a bed of hay to lay her on.

"Now then, boy, you go for the doctor. My women folks will see to the lady, and she'd better keep quiet up yender till we see what the matter is," said the farmer, when the pale girl was lifted in as carefully as four strong arms could do it. "Hold on," he added, as Ben made one leap to Lita's back. "You'll have to go to Berryville. Dr. Mills is a master hand for broken bones and old Dr. Babcock aint.

'Tisn't but about three mile from here to his house, and you'll fetch him 'fore there's any harm done waitin'."

"Don't kill Lita," called Miss Celia from the cart, as it began to move.

But Ben did not hear her, for he was off across the fields, riding as if life and death depended upon his speed.

"That boy will break his neck!" said Mr. Paine, standing still to watch horse and rider go over the wall as if bent on instant destruction.

"No fear for Ben, he can ride anything, and Lita was trained to leap," answered Miss Celia, falling back on the hay with a groan, for she had involuntarily raised her head to see her little squire dash away in gallant style.

"I should hope so; regular jockey, that boy. Never see anything like it out of a race-ground," and farmer Paine strode on, still following with his eye the figures that went thundering over the bridge, up the hill, out of sight, leaving a cloud of dust behind.

Now that his mistress was safe, Ben enjoyed that wild ride mightily, and so did the bay mare; for Lita had good blood in her, and proved it that day by doing her three miles in a wonderfully short time. People jogging along in wagons and country carry-alls, stared amazed as the reckless pair went by. Women, placidly doing their afternoon sewing at the front windows, dropped their needles to run out with exclamations of alarm, sure some one was being run away with; children playing by the roadside scattered like chickens before a hawk, as Ben passed with a warning whoop, and baby-carriages were scrambled into door-yards with perilous rapidity at his approach.

But when he clattered into town, intense interest was felt in this bare-footed boy on the foaming steed, and a dozen voices asked, "Who's killed?" as he pulled up at the doctor's gate.

"Jest drove off that way; Mrs. Flynn's baby's in a fit," cried a stout lady from the piazza, never ceasing to rock, though several passers-by paused to hear the news, for she was a doctor's wife, and used to the arrival of excited messengers from all quarters at all hours of the day and night.

Deigning no reply to any one, Ben rode away, wishing he could leap a yawning gulf, scale a precipice, or ford a raging torrent, to prove his devotion to Miss Celia, and his skill in horsemanship. But no dangers beset his path, and he found the doctor pausing to water his tired horse at the very trough where Bab and Sancho had been discovered on that ever-memorable day. The story was quickly told, and, promising to be there as soon as possible, Dr. Mills drove on to relieve baby Flynn's inner man, a little disturbed by a bit of soap and several buttons, upon which he had privately lunched while his mamma was busy at the wash-tub.

Ben thanked his stars, as he had already done more than once, that he knew how to take care for a horse; for he delayed by the watering-place long enough to wash out Lita's mouth with a handful of wet grass, to let her have one swallow to clear her dusty throat, and then went slowly back over the breezy hills, patting and praising the good creature for her intelligence and speed. She knew well enough that she had been a clever little mare, and tossed her head, arched her glossy neck, and ambled daintily along, as conscious and coquettish as a pretty woman, looking round at her admiring rider to return his compliments by glances of affection, and caressing sniffs of a velvet nose at his bare feet.

Miss Celia had been laid comfortably in bed by the farmer's wife and daughters, and, when the doctor arrived, bore the setting of her arm bravely.^[Page 534] No other serious damage appeared, and bruises soon heal, so Ben was sent home to comfort Thorny with a good report, and ask the squire to drive up in his big carry-all for her the next day, if she was able to be moved.

Mrs. Moss had been wise enough to say nothing, but quietly made what preparations she could, and waited for tidings. Bab and Betty were away berrying, so no one had alarmed Thorny, and he had his afternoon nap in peace,—an unusually long one, owing to the stillness which prevailed in the absence of the children; and when he awoke he lay reading for a while before he began to wonder where every one was. Lounging out to see, he found Ben and Lita reposing side by side on the fresh straw in the loose box, which had been made for her in the coach-house. By the pails, sponges and curry-combs lying about, it was evident that she had been refreshed by a careful washing and rubbing down, and my lady was now luxuriously resting after her labors, with her devoted groom half asleep close by.

"Well, of all queer boys you are the queerest, to spend this hot afternoon fussing over Lita, just for the fun of it!" cried Thorny, looking in at them with much

amusement.

"If you knew what we'd been doing you'd think I ought to fuss over her, and both of us had a right to rest!" answered Ben, rousing up as bright as a button; for he longed to tell his thrilling tale, and had with difficulty been restrained from bursting in on Thorny as soon as he arrived.

He made short work of the story, but was quite satisfied with the sensation it produced; for his listener was startled, relieved, excited and charmed, in such rapid succession, that he was obliged to sit upon the meal chest and get his breath before he could exclaim, with an emphatic demonstration of his heels against the bin:

"Ben Brown, I'll never forget what you've done for Celia this day, or say 'bow-legs' again as long as I live!"

"George! I felt as if I had *six* legs when we were going the pace. We were all one piece, and had a jolly spin, didn't we, my beauty?" and Ben chuckled as he took Lita's head in his lap, while she answered with a gusty sigh that nearly blew him away.

"Like the fellow that brought the good news from Ghent to Aix," said Thorny, surveying the recumbent pair with great admiration.

"What fellow?" asked Ben, wondering if he didn't mean Sheridan, of whose ride he had heard.

"Don't you know that piece? I spoke it at school. Give it to you now; see if it isn't a rouser."

And, glad to find a vent for his excitement, Thorny mounted the meal-chest, to thunder out that stirring ballad with such spirit that Lita pricked up her ears, and Ben gave a shrill "Hooray!" as the last verse ended,

"And all I remember is friends flocking round,
As I sat with his head 'twixt my knees on the ground,
And no voice but was praising this Roland of mine,
As I poured down his throat our last measure of wine,
Which (the burgesses voted by common consent)
Was no more than his due who brought good news from Ghent."

(To be continued.)



MASTER MONTEZUMA.

(With Illustrations copied from Mexican Hieroglyphics.)

By C.C. Haskins.

[Note.—Montezuma II., the last of the Aztec (or native Mexican) emperors, was born about 1480. He was taken prisoner by Hernando Cortes, the commander of the Spanish army which conquered Mexico, and, in the hope of quelling an insurrection which had arisen among his former subjects, he consented to address them from the walls of his prison. Stung by the apparent desertion of their leader to the cause of the enemy, the Mexicans assaulted him with stones and other missiles. He was struck on the temple by one of the stones, and died from the effects in a few days. The illustrations are true copies of old Mexican pictures, which appeared originally in the "Collection of Mendoza," a work frequently referred to by all writers on ancient Mexico.—C.C.H.]

The Emperor Montezuma was a great man, and historians have recorded much about him, but of his earlier life, when he was plain Master Montezuma, comparatively little is known of this rising young gentleman.

Master M. commenced his earthly career as a crying baby, in the year "one cane," which, when properly figured down according to the Gregorian calendar, would be about the year of our Lord 1480.

No sooner had Master M. reached the fourth day of his existence, than the nurse, under instructions from his anxious mamma, took off what few clothes the poor boy had on, and repairing to the baptismal font in the yard, sprinkled cold water upon his naked breast and lips, presented his credentials in the shape of offerings to propitiate the gods of war, agriculture, etc., whose names you will find further along in this history, repeated a prayer in which "the Lord was implored to wash away the sin that was given him before the foundation of the world, so that the child might be born anew," and told the three little boys who sat near by, what Master M.'s name was to be. The three little boys left off eating their parched corn, and boiled beans, repeated the name, and the little baby was christened.

Now, if Master M. had been a girl—which he was not—the offerings would have been a mat, a spinning machine and a broom, all of which would have been buried under the *metate*, the stone where corn was ground. As it was, the offerings were implements of war, articles of metal, pottery, etc., and these were

buried, as near as they could guess at the location, where they either hoped or feared there might some day be a battle with their enemies.

When Master M. had eaten and slept and kicked and cried for sixteen days longer, his parents took him to the priest, and to the teacher, and promised that he should be instructed by these worthy gentlemen in war, politics, religion, and other branches of general education. They promised that he should be an Alfalqui, or priest, and should also serve in the army as a soldier. In that little, wiggling baby, that seemed all fists and mouth, it was impossible to foresee the future Emperor of Mexico, whose name has since become familiar to the civilized world.

Young Master M. worried along pretty well, and up to six years of age had done nothing remarkable. At this age he was granted one and one-half rolls at a meal, and commenced doing little errands and picking up scattered beans and corn in the Tianquez, which is what the Mexicans called the market-place.

The restless spirit of a military chieftain now began to show itself in the embryo warrior, and, by the time he had reached his eighth year, discipline became necessary to curb his growing inclination to despotism. He was fast becoming one of that class of boys who think "it's too bad to be good all the time." In the second picture see the scalding tears! Whether Master M. is sorry that he has done wrong, or whether he only fears being pricked with those terrible thorns of the aloe with which he is threatened, or is crying because he is cold, who shall tell? It is hard, sometimes, to tell what eight-year-old boys are crying for, whether they live in the United States or in Mexico.

Master M. may have been better than most boys, and it may be that his father was a better driver than leader for his little ones. Some fathers are. In any event, when Master M. was ten years old there came another opportunity for weeping and wailing, and Master M. was submitted to the mortification of lying on the damp ground all day while he listened to a parental lecture; and this, too, after he was twelve years old!

Then Master M. reformed, and became an industrious, faithful boy. I have sometimes questioned whether he wasn't hungry, and if he had been better fed whether he would not have done better. At fourteen years of age they gave him two rolls at a meal, and he was instructed in the art of fishing with a net. You can tell how old the boy is by the number of round marks in the picture, and the person who is speaking is denoted by a tongue in front of the mouth.

When his fifteenth year came, Master M. found he would have plenty to do. After this, old Mr. M. had no trouble with him. It is curious—the[Page 536] more we have to do, the less liable we are to do something we should not, and—let us all study on that half an hour, some day, and see what we can make of it.

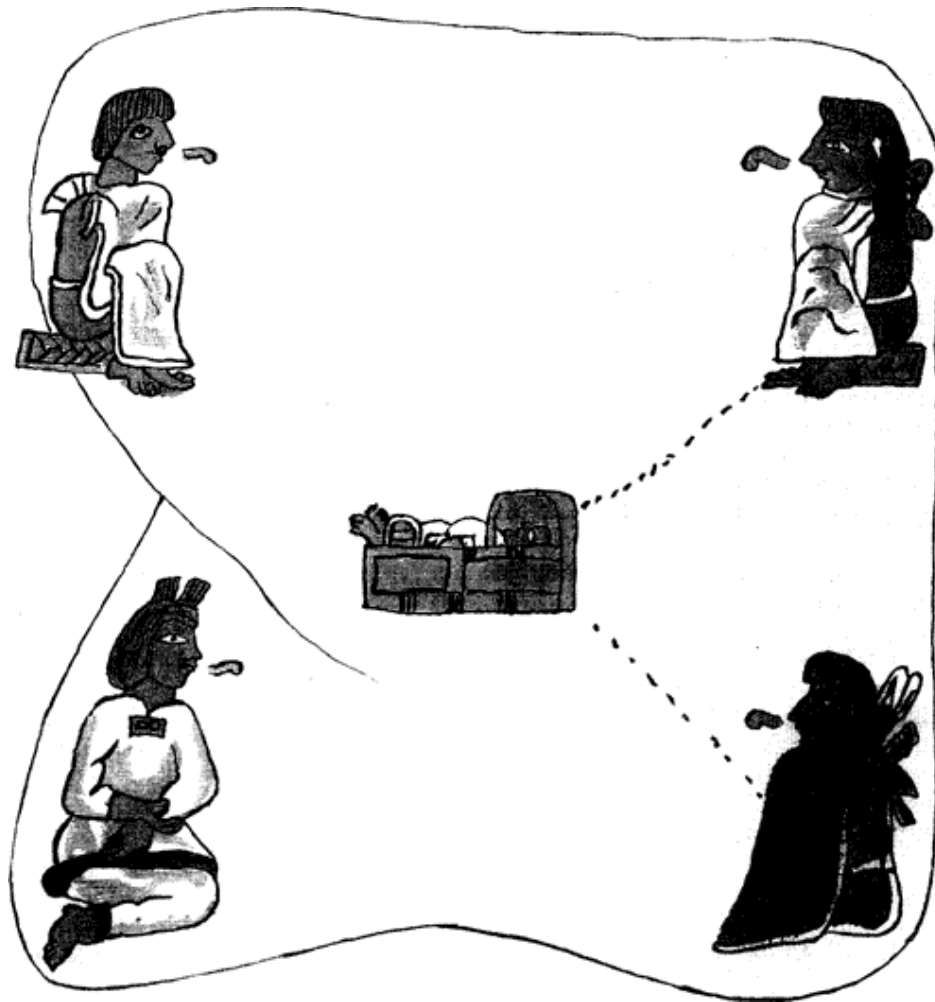

MASTER MONTEZUMA'S PARENTS TAKE HIM TO THE PRIEST AND THE TEACHER.

He had two teachers, the priest and the military professor. It seemed as if everything was to be learned. There was arithmetic, he learned to make figures. A round, blue dot stands for one.

Five of them make five, and ooooo-o (five and one) is six, and in that way it runs up to ten. If he wanted to say "twenty" he made a flag, and for forty he made two flags.

Just imagine such a multiplication table as this: Five times four is one flag. Flag times flag is one plume. Flag times plume is one purse! Let's see; a purse, then, would equal 8,000. Yes, and if he wanted to write 4,000 he would draw only half a purse. All the examples in their arithmetic were worked by such tables as these.

Then there were lessons in time. He had to learn that five days make a week, four weeks make a month, and eighteen months make a year; and as all that footed up only three hundred and sixty days, they threw in what they called the five unlucky days that belonged to no month, to fill up before they commenced a new year. And then he found another arrangement for doing what we do with our leap-year, for, once in fifty-two years they put in twelve and one-half extra days, which is something like setting the clock ahead when you find it is too slow by the town bell or the fire alarm.

He learned that this kind of calendar had been in use a long time, and was the result of careful study and calculation by the wise priests of the olden time; and, when he wanted to know how long, he counted up the bundles of reeds which represented centuries, and found that it had been in use over four hundred years. And all this, you must remember, was before San Salvador was discovered^[Page 537] by Columbus. Then he had to study all about the naming of the years and the cycles. How, if this year was "one rabbit," next year would be "two cane," the third "three flint," the next "four house," and these four elements, representing air, water, fire, earth, would be thus repeated up to thirteen, and then they would commence at one again, so that the fourteenth year would be "one cane," etc., and in four of these cycles of thirteen they would reach a cycle of fifty-two years, or, as they called it, a "bundle," and as the twelve and one-half days additional would end one cycle of fifty-two years at midday, and the next at midnight, they bundled two of these together and called it "an old age."

The number fifty-two was an unlucky number, and these old Mexicans believed that at the end of a cycle of that number of years, at some time, the world would be depopulated, the sun put out, and, after death and darkness had reigned awhile, it would all begin afresh with a new race of people.

So, when a cycle or bundle was completed, all fires were extinguished and not rekindled during the five unlucky days. Household goods which could no longer be of any service, dishes, household articles, etc., were broken; every one gave up all hope, and abandoned himself to despair while awaiting the expected ruin.

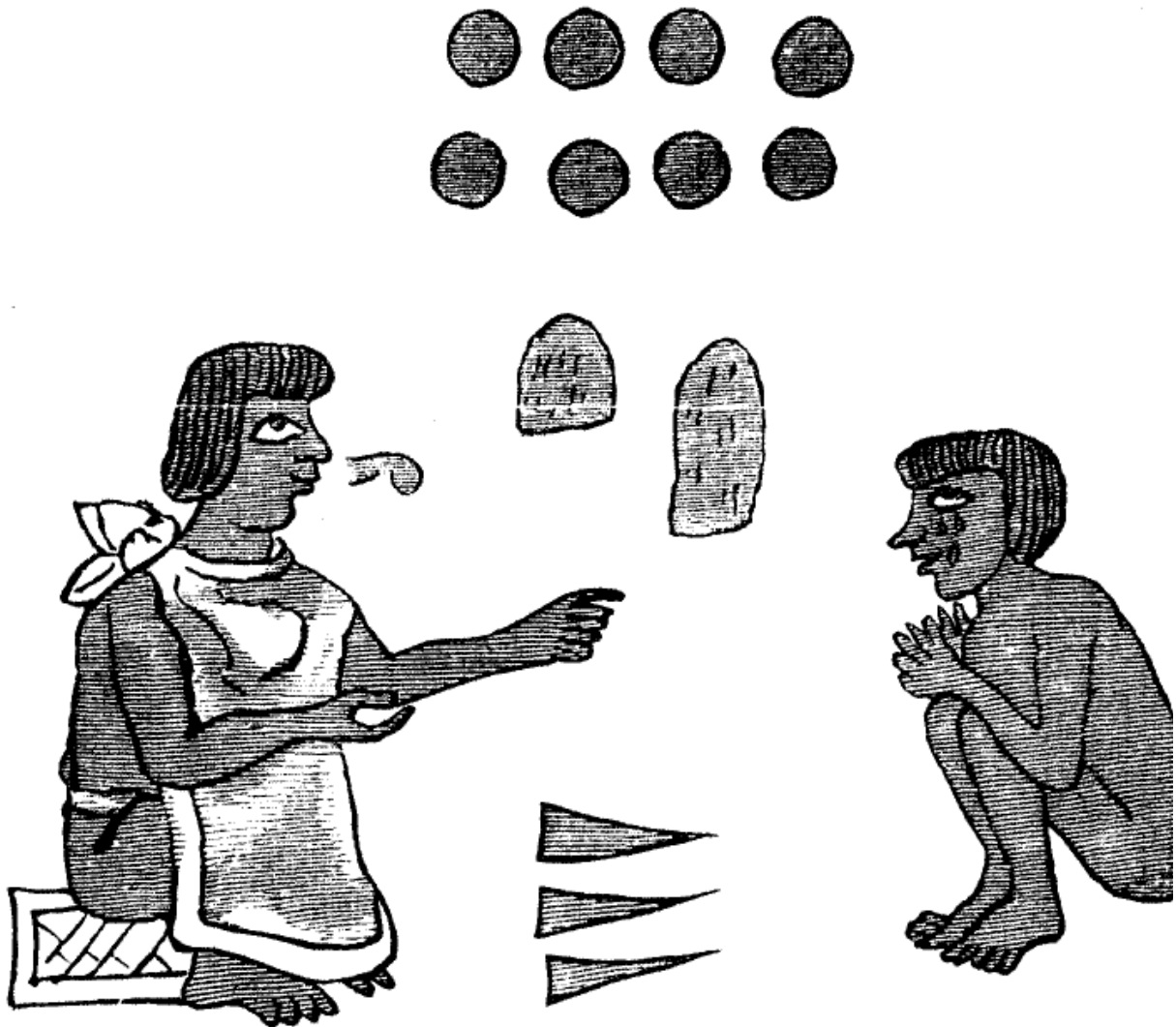

MASTER MONTEZUMA MUST BE PUNISHED.

On the evening of the fifth day of sorrow, the priests gathered the people together in a procession and marched to a temple, about two leagues from the city.

Here they would sit like bumps on a log until midnight, and then, when the constellation which we call the Pleiades came exactly overhead, the danger was over. Two sticks were rubbed together over the breast of a captive who had been selected for the sacrifice, until fire was produced by the friction, the funeral pile was lighted, the body burned, and messengers, many of whom could run long distances, at the rate of seven or eight miles an hour, would light their torches and spread the joyful news of danger averted, while carrying the "new fire" into all parts of the empire. Then would follow a regular old-fashioned frolic,

something like a centennial,—a jollification few had ever seen and most would see but once in a life-time. There must be no drunkenness, however; that was a high crime, in some instances punished by death. If the intemperate party, man or woman, was over seventy years of age, however, no notice was taken of it,—they were old, and had rights and privileges not granted to younger members of the community.

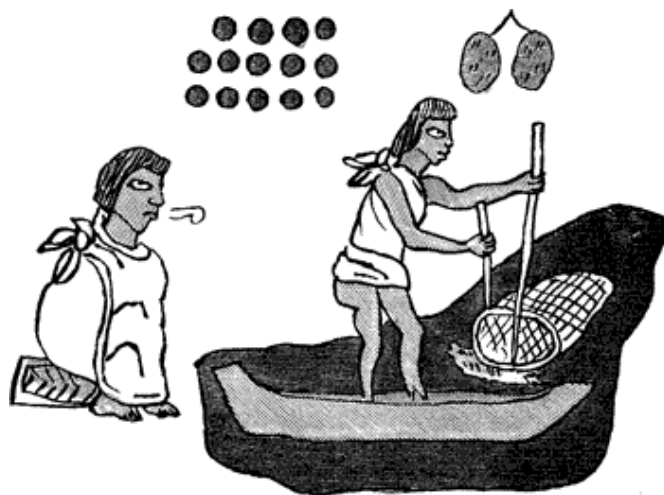

MASTER MONTEZUMA IS TAUGHT HOW TO FISH.

Master M. had much to learn about deities. At the head of these stood one, infinite, supreme ruler, "the unknown God," and next beneath him came [Page 538] Tezcatlipoca, the "son of the world," supposed to be the creator of the earth.



MASTER MONTEZUMA IS TALKED TO BY HIS FATHER.

Huitzilopotchli was the god of war, a sort of Mars, but with very much more name. Then there was the god of air, Quetzatcoatl, who controlled vegetation, metals, and the politics of the country. Here is something Master M. was taught to believe of him:

When this god, whom we will call Q, was on earth, vegetation was so wonderfully prolific that a single ear of corn was all a man could carry. Everything the people needed grew spontaneously. Cotton grew more beautifully tinted than the dyers of the present time could color it. Richest perfumes loaded temperate breezes, and everywhere the gaudiest-colored birds filled the air with most entrancing harmonies. Q had some little difficulty, however, with the rest of the gods, and was obliged to leave his little paradise. When he embarked in his wizard snake-skin canoe on the shore of the gulf, he told his friends that his descendents would one day return and bless the land as

he had done, and that they would be like him,—tall, fine looking, with dark hair, white skins, and flowing beards. Alas! this belief was in no small degree the cause of their ruin; for the invading Spaniards quite nearly answered this description of Q's descendants.



CARRYING THE BRIDE.



THE WEDDING OF MONTEZUMA.

There were thirteen of the principal deities, as Master M. learned, each of whom required sacrifices more or less horrible. For instance, there was the "soul of the world," I forget his other name. He must be propitiated now and then. A year before the fatal day, a tall, beautiful, well-formed, unblemished captive was selected to play the part of this god for one year. He must have all these qualifications to make the resemblance as perfect as possible. He was now treated as a god. Everything he could wish, everything it was thought could possibly conduce to his pleasure, comfort, or happiness, was furnished without stint. He slept on the softest of couches in the most gorgeous of chambers; his raiment was profuse and expensive, and the whole surroundings were, as far as possible, in keeping with his high and holy estate. Birds and music, flowers and

rare perfumes pleased every sense, and everything, save liberty, was his. This happy-go-lucky sort of life continued until the day fixed for the sacrifice. Then joy gave way to sadness, pain, death! Stripped of his costly raiment, he was taken by a procession of priests to a royal barge, thence across a lake to a temple about a league from the city, where, as he mounted the weary steps of the huge edifice, he flung aside the garlands of flowers and broke the musical instruments which had been a joy to him in his past days. At the summit of the temple, in full view of the assembled multitude below, he was barbarously put to death by a priest, in order to propitiate the cruel god to whom the temple was dedicated. And Master M. was taught that the moral of all this savagery was, that human joys are transitory, and the partition between sorrow and happiness is a [Page 539] very thin one, or words to that effect.

Master M. learned that there were many other inferior gods, each of which had festivals, sacrifices, etc., proportioned to his rank and power; that nearly every hour of the day was dedicated to some god or other; but I cannot tell you all he learned of these strange deities.



A PEACE-OFFERING IN THE
YEAR ONE RABBIT.

He studied the history of the temples, and learned why they were four or five stories high with the stairs on the outside, and why he had to go entirely round the temple to find the next flight of stairs as he went up or down; and why each story was smaller than the next lower, and learned that some of these buildings were over one hundred feet square and as many feet high, and had towers forty or fifty feet high on their summits; and all about the everlasting fire which burned on the tops of these temples, and that there were so many of these that the whole country for miles around was always brilliantly illuminated.

I must pass over a long period in the life of Master M. with the mere remark that he graduated in both his military and religious classes with the highest honors, and acquitted himself to the most perfect satisfaction of both the alfalquis, or priests, and the teachcauhs, which is nearly the same as our word teachers.

Master M. had, for a long time, cherished a hope that some day he might press the throne as king of Mexico. So, like the Yorkshire lad who begged salt of a stranger eating eggs near him, so as to have the salt ready in case any one *should* ask him to accept an egg, he prepared himself fully for the possible emergency, and became not only a military general, but a leading alfalqui.

And then he married. I have not room to give you the whole picture, but here is the way it was done.

A lady whose position in society required her to negotiate the match, having previously made all the necessary arrangements, one evening, hoisted the

happy damsel on her back, and accompanied by four young women (I have drawn only one) each bearing a torch, headed the joyous procession and marched to the house of Master M., where she dropped her cargo of precious humanity. Then the alfalqui asked them if they were mutually agreed on matrimony, and of course, they said "yes," when he proceeded to tie their clothes together. Then two old patriarchs and two good old grandmothers (one of each of which I have copied for you) delivered little sermons suited to the occasion. The new couple walked seven times round a blazing fire, partook of a feast with their friends, heard a final sort of a "ninety-ninthly and to conclude" parting word from the four old people, and then, just as all married people do, went to housekeeping, and having their own way as much as possible. One thing they could not do. There was no law of divorce to appeal to then; death was the only judge who could entertain the question of separation.

Master M. will now disappear, to re-appear as the Emperor. In the year "ten rabbits," or A.D. 1502, the monarch died, and the electoral college selected Master M. to supply his place. In the household of each monarch there was an electoral board of four nobles, whose duty it was, on the death of the ruler, to elect his successor from among the sons and nephews of the crown.

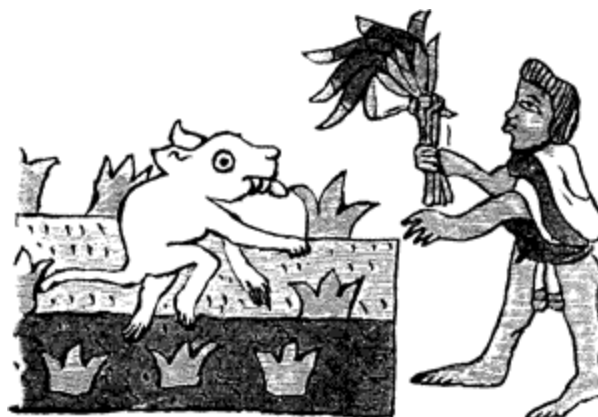

PROTECTING THE GRAIN FROM RATS, IN THE YEAR ONE RABBIT.

Having^[Page 540] done this, and so notified the successor, they selected four nobles to fill their own places, and vacated their electoral chairs. Master M. when waited upon to be notified of his election to fill his uncle's place, was very busy sweeping down the stairs in the great temple dedicated to the god of war!

Four years after becoming emperor, Montezuma, to appease the gods, made a sacrifice of a young gentleman captive by transfixing him with arrows. This, you see, was in the year "one rabbit." It is recorded that in this year the rats overran the country so completely that the inhabitants had to stand

guard at night with blazing torches to prevent their devouring the grain sown in the fields.

With the last picture, I take pleasure in introducing to you Master M. in his new position as Emperor of Mexico, seated in the royal halls.

For further particulars, read "The Conquest of Mexico," by Prescott.

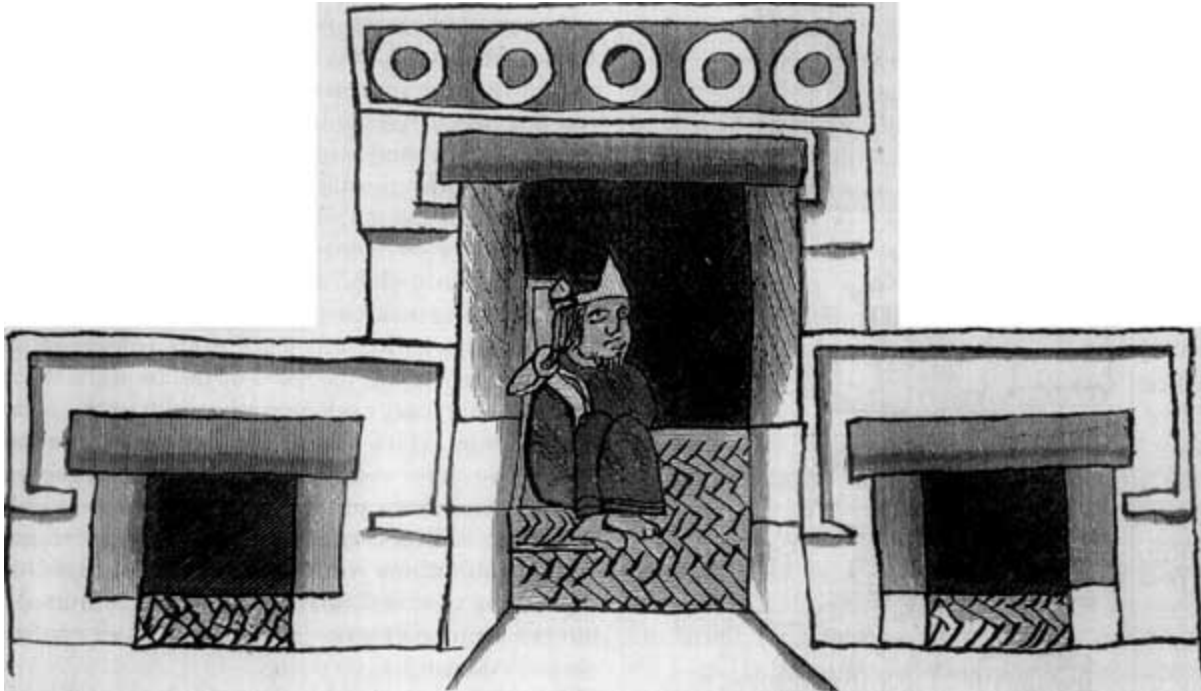

THE EMPEROR MONTEZUMA, SEATED IN THE ROYAL HALLS.

A LONG JOURNEY.

BY JOSEPHINE POLLARD.

"We sail to-day," said the captain gay,
As he stepped on board the boat that lay
So high and dry, "Come now, be spry;
We'll land, at Jerusalem by and by!"

Away they sailed, and each craft they hailed;
While down in the cabin they bailed and bailed;
For the sea was rough, and they had to luff
And tack, till the captain cried out "Enough!"

They stopped at Peru, this jolly crew,
And went to Paris and Timbuctoo;
And after a while they found the Nile,
And watched the sports of the crocodile.

They called on the Shah, and the mighty Czar,
And on all the crowned heads near and far;
Shook hands with the Cid—they really did!
And lunched on top of the pyramid!

To Afric's strand, or northern land,
They steer as the captain gives command;
And fly so fast that the slender mast
Goes quivering, shivering in the blast!

Then on to the ground with a sudden bound,
Leaps Jack—'t was a mercy he wasn't drowned!
The sail is furled, the anchor hurled,
"We've been," cry the children, "all round the world!"

By billows tossed, by tempests crossed,
Yet never a soul on board was lost!
Though the boat be a sieve, I do not grieve,
They sail on the ocean of "Make-believe."

THE LITTLE RED CANAL-BOAT.

BY M.A. EDWARDS.

The morning sun had not mounted high enough in the sky to send his rays into Greta's room, when she was awakened by a noise. She listened. It was the sound of a boat grating against the side of the canal. Who could be coming to their back door so early? She sprang out of bed, and ran quickly to the open window. A disappointment awaited her. It was only her father's boat, which the maid-servant Charlotte was pushing along, slowly making her way to the landing-stairs.

"Where have you been so early, Charlotte?" called out Greta.

"Are you there, youngsters?" said Charlotte, looking up at the two bright faces at the window; for the little Amelia had been roused by her sister's wild jump from the bed, and had also run to the window.

"Bad Charlotte, to wake us so early!" cried Amelia.

Charlotte laughed. "You wouldn't think me bad, Minchen, if you knew all the good things I've been buying at market. Have you forgotten your cousins are coming to-day, all the way from over the sea? I'm sure they'll be hungry enough."

"What you got?" asked Amelia (usually called Minchen).

"Fine Beemster cheese, sweet butter, fresh salad, and plenty of fruit. And there are lots of good things at the bottom of the basket. I'll leave you to find out what they are." And Charlotte made the boat fast, and carried the heavy basket into the house.

It was not necessary for Charlotte to remind these little girls of the cousins who lived in the city of New York, in the far-off land of America. For the last month little else had been talked of in the Van Schaick mansion besides

the expected visit of the Chester family. Mrs. Van Schaick and Mrs. Chester were sisters, and this was but the second visit the latter had paid her old Holland home since her marriage. On the first visit her children were not with her; but now Mr. Chester was coming, and the two boys. Many were the wild speculations the girls indulged in with regard to Americans,—what they would look like, and what they would say and do.

Great, then, was their surprise, when the travelers arrived, to find that their aunt Chester was very like their mother in appearance and dress. Mr. Chester did not in the least resemble their father, but he was not unlike many other men they had seen, and he did not dress in wild-beast skins. As for the boys, Greta poured her tale of woe into the ears of the sympathizing Charlotte. "They are just like English boys!" she said, contemptuously. Greta had often seen English boys, and there was nothing uncommon about them.

This was soon forgotten, however, when Greta discovered what pleasant companions the boys were, and that they could put the Dutch words together almost as correctly as Greta herself. Will Chester, who had reached the dignified age of thirteen, had felt much troubled at the thought that he would have "only girls" to play with at Zaandam, especially as Greta was a year younger than himself. But when the two girls, instead of bringing forward their dolls and tea-sets with which to entertain their visitors, produced from their treasures two good-sized toy canal-boats, fully equipped with everything a canal-boat needed, he admitted to himself that girls who liked to sail boats might be good for something.

Secretly, however, he thought that a canal-boat was a poor kind of vessel to have, and wished his cousins owned such beautiful ships as he and Martin had; for among the last things bought before leaving New York were two little sailing-vessels—the "America" and the "Columbus." Mr. Chester said Holland was full of water, and these were proper toys to take there.

The two canal-boats, being precisely alike, were distinguished from each other only by their names. Greta's had "Wilhelmina" painted on the side in black letters, while Minchen's had "Gouda" in red letters. They were similar to American canal-boats in shape, and of a dark red-brown color. Will thought them stumpy and heavy-looking; and he did not admire the red sails

with crooked gaffs, and smiled at the blue pennants, stretched out on stiff frames that turned with the wind. But when Greta showed him a tiny windlass on the deck, by means of which she easily raised and lowered the mast, he came to the conclusion that a Dutch canal-boat was not to be despised.

"I do this when we pass under bridges," she explained.

"Where are your mules for drawing your boat?"

"My boat sails!" she said, proudly. "If there is no wind, I drag it along myself. That is the way we do in our country."



"CHARLOTTE WAS PUSHING THE BOAT ALONG, MAKING HER WAY TO THE LANDING-STAIRS."

The American vessels were now unpacked and displayed. When the girls saw these sharp-prowed, graceful ships, with their tapering masts and pretty[Page 542] sails, their eyes glistened, and they declared that never before had they seen anything so lovely. Their pride in their canal-boats suffered a

woful downfall. The boys proposed to try all the vessels on the canal at the back of the house, but Greta objected.

"Mother never lets us go there to sail our boats," she said. "It is a dirty place, and she is afraid we will fall in. But there is a beautiful stream by the mill where we are going to-morrow, and there we can try our boats, and see which goes the fastest."

"Let us take a walk, then," said Martin. "I want to look at this queer place."

The Van Shaicks lived in Zaandam, and it is indeed a queer place to American eyes. It is a large town, with but two streets, one on each side^[Page 543] of the Zaan River; but these two extend for a long distance, and are crossed at frequent intervals by canals, so that Martin soon got tired counting the little bridges the children passed over in their walk. Will was not quite sure whether the brick-paved street was all road-way or all sidewalk.

"I don't see any carriages," he said, after studying this matter for some time.

"People don't ride much here," said Greta. "There are plenty of carriages in Amsterdam."

"How do you get about, then?"

"On our feet and in boats. Look at our fine river, and there are ever so many canals! What do we want with carriages?"

"It must be jolly going everywhere in boats," said Will. "I should like that!"

"We have some very pretty boats," said Greta, much pleased. "Oh! wouldn't you like to go fishing? I'll ask father to take us some day soon. I saw a net in the market-boat this morning."

"Well, if that isn't funny!" cried Martin, with a burst of laughter. Will joined in the laugh, and Greta looked around in vain to discover the cause of their merriment.

"Looking-glasses on the *outside* of the houses!" explained Martin, pointing to one opposite. "I guess they're put there for the girls to look in as they walk along," he added, mischievously. "They can't wait to get home to admire themselves."

Sure enough, there was a mirror outside the window, set at such an angle that the persons inside the house could see who was passing up and down the street. And there was a mirror on the next house, and the next.

"Why, they are on all the houses!" said Will.

"To be sure!" said Greta. "What is there funny in that? And the girls don't look in them any more than the boys, Mr. Martin. Don't you ever want to know what is going on in the street?"

"Of course I do."

"How are you going to do it without the looking-glass to tell you?"

"Use my own eyes, to be sure!"

"Whose eyes do you use when you look in a glass?" said Greta.

Martin looked puzzled, and had no reply ready; and Will thought his cousin Greta very clever, although she was a girl, and a year younger than himself.

But Martin soon recovered his composure.

"What lots of flowers!" was his next comment. "They are everywhere, except in this brick pavement, and nothing could grow here, it is so clean."

"And such pretty houses in the gardens!" said Will.

"But they are so small," said Martin, "It would take a dozen of them to make a New York house."

"My goodness!" said Greta, turning her head back as far as she could, and looking at the sky. "How do you ever see up to their roofs?"

"Divide Martin's twelve by four, and you will come nearer the truth," said Will, laughing. "But, at any rate, the houses are pretty—painted green and yellow, with red-tiled roofs."

The next thing the boys observed was the loneliness of the streets. In America a town of twelve thousand inhabitants would have more of an air of bustle, they said. Will liked the quiet, "for a change," as he expressed it, and because it made him feel, somehow, as if he owned the place. Martin declared it to be his opinion that the people kept out of the streets for fear that their shoes would soil them, and that accounted for the almost spotless cleanliness everywhere.

The streets were not deserted, however; for, at intervals, there were row-boat ferries across the river, and occasionally a man or woman would be seen in one of these boats.

There were also a number of children, and some women, in the streets. These apparently belonged to the poorer classes. Hats and bonnets were scarce among them, though all the women, and many of the little girls, had on close-fitting muslin caps. They wore short, loose sacques, and short dress skirts, made up without trimmings. The boys were dressed in jackets and baggy trousers. All wore clumsy wooden shoes.

The Van Schaick family followed the French fashions, as we do in America; the difference between the two countries being that here every one attempts to follow the prevailing style, while in Holland this change of fashion is confined to the wealthy; the middle and lower classes preserving the same style of costume from generation to generation.

A good many of the children in the street were carrying painted iron or stone buckets, with a tea-kettle on the top. After proceeding some distance up the street, Will and Martin saw some of them coming out of a basement door-way, still with the buckets in their hands; but clouds of steam were issuing from the tea-kettle spouts!

"What place is that?" asked Will.

"It is the fire-woman's," said Greta.

"And who and what may she be? I have heard of water-women, sometimes called mermaids, but never before did I hear of a fire-woman."

"She don't *live* in fire," said Greta; "she *sells* it. What do the poor people in your country do in summer without a fire-woman? Come and look in."



AT THE FIRE-WOMAN'S.

By this time they had reached the place. Over the door was the sign "*Water en vuur te koop.*"¹ [Page 544] It was not necessary for the children to go inside. They could see the whole apartment through the wide-open doorway. An old woman stood by a stove, or great oven, with a pair of tongs, taking up pieces of burning peat and dropping them into the buckets of the children, and then filling their tea-kettles with boiling water from great copper tanks on the stove. For this each child paid her a Dutch cent, which is less than half of one of ours.

"I understand it," said Will, after they had stood at the door some time, amused at the scene. "This saves poor people the expense of a fire in the summer-time. They send here for hot water to make their tea."

"Yes," said Greta, "and for the burning peat which cooks the potatoes and the sausage for their supper."

"Why don't they use coal?" asked Martin. "It is ever so much better."

"No, the peat answers their purpose much better," said Will. "It burns slowly, and gives out a good deal of heat for a long time."

"And the smell of it is so delicious," added Greta.

A little further on; the children came out on an open space, which gave them a good view of the surrounding flat country, and of the wind-mills that stand about Zaandam—a forest of towers. It was a marvelous sight. Hundreds of giant arms were beating the air, as if guarding the town from invisible enemies.

Greta was proud and pleased that her cousins were so impressed with the great numbers of towers and the myriads of gigantic whirling spokes.

"My father says there is nothing grander than this in all Holland," she said. "There are four hundred of them, and more, but you can't see them all from here. Do you see that mill over yonder? That is my father's, and we are going there to-morrow."

The boys could not distinguish one tower from another at that distance.

"What kind of mill is it?" asked Will.[Page 545]

"A flour-mill."

"Are all these flour-mills?"

"Oh no! There are saw-mills, colza-oil mills, mustard-mills, flax-mills, and other kinds I don't remember."

It was now nearly supper-time, and the little group returned home.

The next morning, the whole party—four grown-up people, four youngsters, and four boats (the "Wilhelmina," the "Gouda," the "America," and the "Columbus")—were all taken up the Zaan River in a row-boat for about three miles, and then up a small stream to the mill where they were to spend the day.

The first thing in order was the inspection of the mill, which was unlike anything they had ever seen in America. The tower was of brick. It was three stories high, over a basement. In the basement were the stables and wagon-house; over this was the granary, and flour and meal store; above this were the bolting-rooms, the ground wheat running through spouts to the store-rooms below. On the next floor above were the mill-stones, and the simple machinery that turned them. And, above all, at the very top of the tower, was the main shaft of the great wings outside. These wings caught the winds, and compelled them to work the machinery with such force as to make the strong tower tremble. There were balconies around the first and third stories of the mill. It was quite a picturesque object standing among low trees on a pretty, quiet stream, the banks of which were higher and more uneven than was usual in that part of the country.

The miller lived in a small house near the mill with his wife and his little daughter Hildegarde, the latter of whom was near Greta's age.

The boys did not take as much interest in the miller's house as their parents took; but when they were shown into a large outer room, and were told it was the cow-stable, they had no words with which to express their astonishment. They would have said it was the show-room of the place. There was not a speck on the whitewashed walls; the pine ceiling was so clean it fairly glistened; there were crisp, white muslin curtains at the windows. The raised earthen floor was covered with pure white sand, arranged in fancy designs. There were some small round tables standing about, and on them were ornaments of china and silver, and a variety of knick-knacks.

During the summer the cows were in the pasture day and night, but in the winter they occupied this room. Then the tables were removed, but the

place was kept very neatly. This was necessary, for the stable adjoined the house, and the party passed into the barn through a door in the cow-stable.

All except the two boys. Will hung back and motioned to Martin not to go into the barn.

"I am tired of this sort of thing," he said. "Let us go and sail our boats."

"Very well," said Martin, "I'll call the girls."

"No," said Will; "there are too many of them. They'll only be in the way. They'll have a good time together, and we'll have some fun by ourselves."

Martin seldom dissented from Will's decisions, so the two boys went back into the house to get their ships, and passed out of another door to the bridge and across the stream. They had gone but a short distance when Martin, who had seemed very thoughtful, stopped opposite the mill.

"There is a man in the balcony," he said. "I'll ask him to call to the girls to come. It isn't fair to go without them. You know Greta thought *so* much of sailing her boat with ours."

"Nonsense," said Will. "She has got other company now. I don't believe they know how to manage their boats, and we will have to help them. Girls always have to be taken care of."

"But," persisted Martin, "you said that Greta was real smart and a first-rate fellow—girl, I mean."

"She is well enough for girls' plays; but what can she know about boats? Come along!"

Martin said no more, and the boys proceeded for some distance up the stream.

"If we go around that bend," said Will, "we will be out of sight of the mill, and can have our own fun."

Around the bend they found a bridge, and a little way above this the stream widened into a large pool, the banks of which were shaded by willows. There they launched the schooner "America" and the sloop "Columbus" with appropriate ceremonies. The sails and the rudders were properly set for a trip across the pool. The ships bent gracefully to the breeze, and went steadily on their course, the little flags waving triumphantly from the mast-heads. They moved so gracefully and behaved so beautifully that Martin expressed his sorrow that the girls were not there to see them. Will made no reply, but he felt a twinge of remorse as he remembered how Greta had looked forward to this sail as a great event. He tried to quiet his conscience with the consideration that it was much better for her not to be there; for she would certainly have felt mortified at the contrast between their pretty vessels and the poor canal-boats.

The boys crossed the bridge, and were ready for the arrival of their vessels in the foreign port. Then they started them on the return voyage and recrossed the bridge to receive them at home.

This was done several times, but at last there was [Page 546] an accident. Will's schooner, the "America," from some unknown cause, took a wrong tack when near the middle of the pool, and going too far up, got aground upon a tiny, grassy island. She swayed about for a minute, and the boys hoped she would float off, but soon the masts ceased to quiver. The "America" had quietly moored herself on the island as if she intended to remain there forever. What was to be done? The longest pole to be found would not reach the island from either bank, or from the bridge, and the pool was deep. Will began to think it was a pretty bad case.



THE BOYS WITH THEIR BOATS.

"What a beauty!" "Isn't it just lovely!" "Pretty! pretty! pretty!"

These exclamations came respectively from Greta, Hildegarde, and Minchen, and had reference to the "Columbus," which was gliding up to the bank where the boys stood, with its sails gleaming in the sunshine, while it dipped and courtesied on the little waves. The girls were coming around the bend. Greta and Minchen had their canal-boats, and Hildegarde carried a great square of gingerbread.

"That's the most beautiful thing I ever saw!" cried Greta. In her admiration of the vessel, she had forgotten her wounded dignity. For she had arranged with Hildegarde that, after giving the [Page 547] boys their share of gingerbread, they should walk proudly and silently away.

As Greta had broken the compact by speaking, Hildegarde entered upon an explanation: "We have been down the stream looking for you—" But here she was interrupted by a frown from Greta, who suddenly recollected the slight that had been put upon them.

"Naughty boys to run away!" said little Minchen. "You sha'n't see my boat sail!"

"My ship is aground on that island," said Will, willing to change the subject. "I have no way of getting her off. I wonder if the boat we came in is too large to be got up here."

"The boat was taken back to Zaandam," said Hildegarde, "and our boat is away, too."

"The 'America' will have to stay where she is, then," said Will, trying to speak cheerfully.

"Pretty ship is lost! Too bad!" said Minchen, pityingly. Then brightly: "I'll give you mine!-*may be*," she added in a doubtful tone, as her glance fell lovingly upon the boat she was hugging under her arm.

Meantime, Greta had been studying the situation. She now turned to Will. "I can get your ship off," she said. "Take care of my boat till I come back, and don't sail her on any account. I won't be gone long."

She handed her boat to Will, and was around the bend in an instant; and it was not very long before the anxious group heard the sound of her rapid footsteps returning. Will thought she had gone to the mill to get some one to help them, but she came back alone, and all she brought with her was a large ball of cord.

Martin and Minchen asked her twenty questions while she made her preparations, but she would not reveal her plans, although it was evident from the way she went to work that she had a very clear idea of what she intended to accomplish.

In the first place, she said the whole party must go further up the bank, so as to get above the "America," which was on the lower edge of the little island. When they had gone far enough, she tied one end of the cord to the rudder-post of her canal-boat. Then she turned the cunning little windlass, and slowly up went the mast to its full height. The next thing was to unfurl the sail, set it properly, and set the rudder,—all of which she did deftly and correctly, making Will feel ashamed of what he had said about the ignorance of girls.

She placed the boat on the water. The sail filled, and off went the "Wilhelmina" with a slow, true, steady motion, her red sail glowing in the sunshine, and her stiff little pennant standing straight out in the wind. As the boat crossed the pool, Greta played out the cord carefully, so as not to impede its motion. When it reached the other side and had gently grounded on the shelving shore, Greta gave the line into Will's hand.

"If you will hold this," she said, "I will go across the bridge."

"Don't trouble yourself to do that," said Will, "I will go over."

"No," said Greta, "I wish to go. I am captain of my own craft, and I know how to manage my 'Wilhelmina.'"

"I had no idea she was so pretty," said Will. "She is a true, stanch little sailer."

"She don't show off until she is on the water," said Greta, smiling, "and then she sails like a real boat. Do you know what I am going to do when I get to the other side?"

"I can guess. You will send your boat back to me from below the island while I hold this end of the cord. That will bring the line around my ship and pull her off."

"I thought of that, but it is too risky. If anything should go wrong with my boat, the line might get tangled; or there might be too great a strain, and the ship would come off with a jerk and be tumbled bottom upward into the water. I intend to untie the cord from the boat, and you and I must walk slowly down toward the 'America,'—I on that side, and you on this. We must hold the cord low so as to catch the mast under the sail, if we can."

"All right," said Will.

Greta walked quickly down the bank, across the bridge, and up the other side until she reached the "Wilhelmina." Placing the boat on the bank for safety, she took the cord off, and, holding it firmly, walked slowly down toward the island. Will did the same on his side of the pool. The cord went skimming over the surface of the water, then it passed above the tops of the long grass on the island. This brought the line on a level with the top-sail. This would not do; for a pressure up there might capsize the schooner. Both of the workers saw that they must slacken the line a little to get it into the proper place. Now was the critical time; if the line was too much slackened it might slip under the vessel and upset it that way. Gently they lowered it until it lay against the mainmast below the sail.

"Take care!" screamed Will to Greta.

"Go slow!" screamed Greta to Will.

Gently they pulled against the schooner, and, inch by inch, she floated off into the open water.

"Hurrah!" shouted Will, as the "America" gave herself a little shake, and, catching the wind, sailed slowly and somewhat unsteadily for the home

port, which, however, she reached in safety. "Wind up the cord!" shouted Greta, just in [Page 548] time to prevent Will's throwing it aside. He wondered what further use she had for the cord. It might go to the bottom of the pool for aught he cared, now that the ship was safe. But he wound it up as directed. It would have been quite a grief to the thrifty little Dutch girl if so much fine cord had been wasted.

Thus ignominiously came in the stately ship "America," which Will had set afloat with such pride! And it is doubtful whether she would have come in at all, but for the stanch Dutch canal-boat that he had regarded with a good deal of disdain.

If Will had been a girl, he would have exhausted the complimentary adjectives of the Dutch language in praise of his cousin; but being a boy, he only said, "Thank you, Greta."

The children remained at the pool until called to dinner; and after that meal, they went back again and stayed until it was time to return to Zaandam, so fascinated were they with sailing their vessels. These changed hands so often that it was sometimes difficult to tell who had charge of any particular boat, and a good deal of confusion was the result. In justice to the "America," it must be stated that she cut no more capers, and was the admiration of all.

Will had his faults, and one of these was the very high estimate he placed on his own opinions. But he was generous-hearted, and he admitted to himself that Greta had shown more cleverness than he in the "America" affair. "She was *quicker*, anyway," he thought. "It is likely that plan would have occurred to me after a time, but she thought of it first. And it was good of her to help me; for she knew that I went away so as not to play with her." It was not pleasant to him to know that a girl had shown herself superior to him in anything he considered his province; but he magnanimously forgave her for this, and he said to Martin, after they were in bed that night:

"I've pretty much made up my mind to give my schooner to Greta. I believe she thinks it the prettiest thing ever made."

"If you do that," said Martin, "I'll give my sloop to Minchen."

This plan was carried out, and the girls were more delighted than if they had had presents of diamonds. But they insisted that the boys should accept their canal-boats in exchange, the result of which was that the Chesters, on their return to America, produced quite a sensation among their schoolmates. For American-built vessels could be bought in many stores in New York, but a Dutch canal-boat, with a red sail, and a mast that was raised and lowered by a windlass, was not to be found in all the city.

Footnote 1: "Water and fire to sell."

THE BUTTERFLY CHASE

BY ELLIS GRAY.

Dear little butterfly,
Lightly you flutter by,
 On golden wing.
Drops of sweet honey sip,
Deep from the clover tip,
 Then upward spring.

Over the meadow grass
Swift as a fairy pass,
 Blithesome and gay;
Toy with the golden-rod,
Make the blue asters nod—
 Off and away!

Butterfly's dozing now,
Golden wings closing now,—
 Softly he swings.
Tiny hands fold him fast,
Gently unclose at last,—
 Fly, golden wings!

Quick! for he's after you,
With joyous laughter new,—
 Mischievous boy!
Swift you must flutter by;
He wants you, butterfly,
 For a new toy!



[Page 549]



HOW TO MAKE A TELEPHONE.

BY M.F.

What is a telephone?

Up go a hundred hands of the brightest and sharpest of the readers of ST. NICHOLAS, and a hundred confident voices reply:

"An instrument to convey sounds by means of electricity."

Good. That shows you have some definite idea of it; but, after all, that answer is not the right one. The telephone does not convey sound.

"What does its name mean, then?" do you ask?

Simply, that it is a far-sounder; but that does not necessarily imply that it *carries* sounds afar. Strictly speaking, the telephone only changes sound-waves into waves of electricity and back again. When two telephones are connected by means of a wire, they act in this way,—the first telephone changes the sound-waves it receives into electric impulses which travel along the wire until they reach the second telephone, here they are changed back to sound-waves exactly like those received by the first telephone. Accordingly, the listener in New York seems to hear the very tones of his friend who is speaking at the other end of the line, say, in Boston.

Still you don't see how.

It is not surprising, for in this description several scientific facts and principles are involved; and all boys and girls cannot be expected to know much about the laws of sound and electricity. Perhaps a little explanation may make it clearer.

The most of you probably know that sound is produced by rapid motion. Put your finger on a piano wire that is sounding, and you will feel the

motion, or touch your front tooth with a tuning-fork that is singing; in the last case you will feel very distinctly the raps made by the vibrating fork. Now, a sounding body will not only jar another body which touches it, but it will also give its motion to the air that touches it; and when the air-motions or air-waves strike the sensitive drums of our ears, these vibrate, and we *hear* the sound.

You all have heard the windows rattle when it thunders loudly, or when cannons have been fired near-by. The sound waves in the air fairly shake the windows; and, sometimes, when the windows are closed, so that the air-waves cannot pass readily, the windows are shattered by the shock. Fainter sounds act less violently, yet similarly. Every time you speak, your voice sets everything around you vibrating in unison, though ever so faintly.

Thus, from your every-day experience you have proof of two important facts,—first, sound is caused by rapid motion; second, sound-waves give rise to corresponding motion. Both these facts are involved in the speaking telephone, which performs a twofold office,—that of the ear on the one hand, that of our vocal organs on the other.

To serve as an ear, the telephone must be able to take up quickly and nicely the sound-waves of the air. A tightened drum-head will do that; or better, a strip of goldbeaters'-skin drawn tightly over a ring or the end of a tube. But these would not help Professor Bell, the inventor of the telephone we shall describe, since he wanted an ear that would translate the waves of sound into waves of electricity, which would travel farther and faster than sound-waves could.

Just when Mr. Bell was thinking how he could make the instrument he wanted, an important discovery in magnetism was made known to him—a discovery that helped him wonderfully. You know that if you hold a piece of iron close to a magnet the magnet will pull it, and the closer the iron comes to the magnet the harder it is pulled. Now, some one experimenting with a magnet having a coil of silk-covered wire around it, found that when a piece of iron was moved in front of the magnet and close to it without touching, the motion would give rise to electric waves in the coil of wire, which[Page 550] waves could be transmitted to considerable distances.

This was just what Mr. Bell wanted. He said to himself, "The sound of my voice will give motion to a thin plate of iron as well as to a sheet of goldbeaters'-skin; and if I bring this vibrating plate of iron close to a magnet, the motion will set up in it waves of electricity answering exactly to the sound-waves which move the iron plate."

So far, good. But something more was wanted. The instrument must not only translate sound-waves into electric impulses, but change these back again into sound-waves; it must not only hear, but also *speak!*

You remember our first fact in regard to sound: it is caused by motion. All that is needed to make anything speak is to cause it to move so as to give rise to just such air-waves as the voice makes. Mr. Bell's idea was to make the iron plate of his sound-receiver speak.

He reasoned in this way: From the nature of the magnet it follows that when waves of electricity are passed through the wire coil around the magnet, the strength of the magnet must vary with the force of the electric impulses. Its pull on the plate of iron near it must vary in the same manner. The varying pull on the plate must make it move, and this movement must set the air against the plate in motion in sound-waves corresponding exactly with the motion setting up the electric waves in the first place; in other words, the sound-motion in one telephone must be exactly reproduced as sound-waves in a similar instrument joined to it by wire.

Experiment proved the reasoning correct; and thus the speaking-telephone was invented. But it took a long time to find the simplest and best way to make it. At last, however, Mr. Bell's telephone was perfected in the form illustrated below. Fig. 1 shows the inner structure of the instrument. A is the spool carrying the coil of wire; B, the magnet; C, the diaphragm; E, the case; F, F, the wires leading from the coil, and connecting at the end of the handle with the ground and line wires. Fig. 2 shows how a telephone looks on the outside.

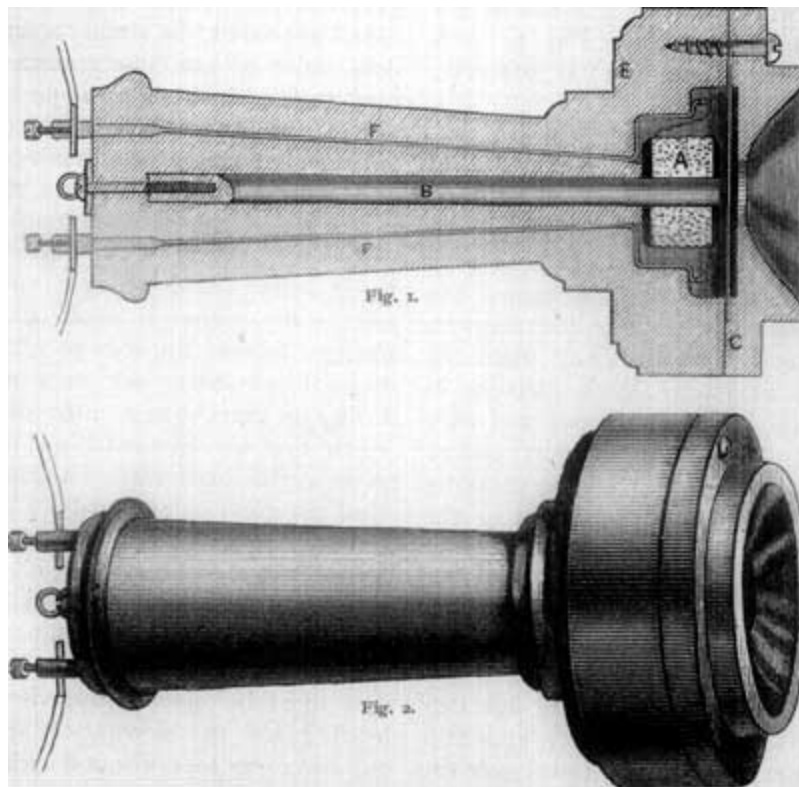

BELL'S TELEPHONE.

So much for description. You will understand it better, perhaps, if you experiment a little. You can easily make a pair for yourself, rude and imperfect, it is true, but good enough for all the tests you may want to apply.

For each you will want: (1) a straight magnet; (2) a coil of silk-covered copper wire; (3) a thin plate of soft iron; (4) a box to hold the first three articles. You will also want as much wire as you can afford, to connect the instruments, and two short pieces of wire to connect your telephones with the ground. (Two wires between the instruments would make the ground-wires unnecessary, but this would use up too much wire.) The magnet and the coil you will have to buy from some dealer in electrical apparatus. They need not cost much. [Page 551] A small cigar-box will answer for the case.

In one end of the box cut a round hole, say, three inches across. Against this hole fasten a disk of thin sheet-iron for the vibrator or "diaphragm." For a mouth-piece use a small can, such as ground spices come in, or even a round paper box.

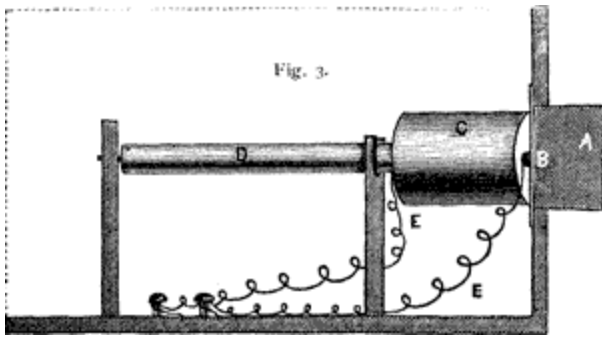

A 'CIGAR-BOX' TELEPHONE.

Now, on the inside of the box, place the magnet, the end carrying the coil almost touching the middle of the diaphragm, and fix it firmly. Then, to the ends of the copper wire of the main coil fasten two wires,—one for the line, the other for the "ground-wire."

This done, you will have an instrument (or rather two of them) very much like Fig. 3. A is the mouth-piece; B, the diaphragm; C, the coil; D, the magnet; E, E, the wires.

The receiving and sending instruments are precisely alike, each answers for both purposes; but there must be two, since one must always be hearing while the other is speaking.

When you speak into the mouth-piece of one telephone, the sound of your voice causes the "diaphragm" to vibrate in front of the magnet. The vibrations cause the magnet's pull upon the diaphragm to vary in force, which variation is answered by electrical waves in the coil and over the wires connected with it. At the other end of the wire the pull of the magnet of the speaking telephone is varied exactly in proportion to the strength of the electric impulses that come over the wire; the varying pull of the magnet sets the diaphragm in motion, and that sets the air in motion in waves precisely like those of the distant voice. When those waves strike the listener's ear, he *seems* to hear the speaker's exact tones, and so, substantially, he does hear them. The circumstance that electric waves, and not sound-waves, travel over the wires, does not change the quality of the resulting sound in the least.

I think you now understand Bell's telephone.

The telephones of Edison, Gray, and others, involve different principles and are differently constructed.

One invention very often leads to another, and the telephone already has an offspring not less wonderful than itself. It is called the speaking-

phonograph. It was invented by Mr. Edison, one of the gentlemen, just mentioned.

Evidently, Mr. Edison said to himself: "The telephone hears and speaks; why not make it write in its own way; then its record could be kept, and any time after, the instrument might read aloud its own writing." Like a great genius as he is, Mr. Edison went to work in the simplest way to make the sound-recorder he wanted. You know how the diaphragm of the telephone vibrates when spoken to? Mr. Edison took away from the telephone all except the mouth-piece and the diaphragm, fastened a point of metal, which we will call a "style," to the center of the diaphragm, and then contrived a simple arrangement for making a sheet of tin-foil pass in front of the style. When the diaphragm is still, the style simply scratches a straight line along the foil. When a sound is made, however, and the diaphragm set to vibrating, the mark of the style is not a simple scratch, but an impression varying in depth according to the diaphragm's vibration. And that is how the phonograph writes. To the naked eye, the record of the sound appears to be simply a line of pin points or dots, more or less close to each other; but, under a magnifier, it is seen to be far more complicated.

Now for the reading. The impression on the foil exactly records the vibrations of the diaphragm, and those vibrations exactly measure the sound-waves which caused the vibrations. The reading simply reverses all this. The strip of foil is passed again before the diaphragm, the point of the style follows the groove it made at first, and the diaphragm follows the style in all its motions. The original vibrations are thus exactly reproduced, setting up sound-waves in the air precisely like those which first set the machine in motion. Consequently, the listener hears a minutely exact echo of what the instrument heard; it might have heard it a minute, or an hour, or a year, or a thousand years before, had the phonograph been in use so long.

What a wonderful result is that! As yet, the phonograph has not been put to any practical use; indeed, it is scarcely in operation yet, and a great deal must be done to increase the delicacy of its hearing and the strength of its voice. It mimics any and every sort of sound with marvelous fidelity, but weakly. Its speech is like that of a person a long way off, or in another room. But its possibilities are almost infinite.

ONLY A DOLL!

BY SARAH O. JEWETT.



Polly, my dolly! why don't you grow?
Are you a dwarf, my Polly?
I'm taller and taller every day;

How high the grass is!—do you see that?
The flowers are growing like weeds, they say;
The kitten is growing into a cat!
Why don't you grow, my dolly?

Here is a mark upon the wall.
Look for yourself, my Polly!
I made it a year ago, I think.
I've measured you very often, dear,
But, though you've plenty to eat and drink,
You haven't grown a bit for a year.
Why don't you grow, my dolly?

Are you never going to try to talk?
You're such a silent Polly!
Are you never going to say a word?
It isn't hard; and oh! don't you see
The parrot is only a little bird,
But he can chatter so easily.
You're quite a dunce, my dolly!

Let's go and play by the baby-house:
You are my dearest Polly!
There are other things that do not grow;
Kittens can't talk, and why should you?
You are the prettiest doll I know;
You are a darling—that is true!
Just as you are, my dolly!

DAB KINZER: A STORY OF A GROWING BOY.

BY WILLIAM O. STODDARD.

Between the village and the inlet, and half a mile from the great "bay," lay the Kinzer farm. Beyond the bay was a sand-bar, and beyond that the Atlantic Ocean; for all this was on the southerly shore of Long Island.

The Kinzer farm had lain right there—acre for acre, no more, no less—on the day when Hendrik Hudson, long ago, sailed the good ship "Half-Moon" into New York Bay. But it was not then known to any one as the Kinzer farm. Neither was there then, as now, any bright and growing village crowding up on one side of it, with a railway station and a post-office. Nor was there, at that time, any great and busy city of New York, only a few hours' ride away, over on the island of Manhattan. The Kinzers themselves were not there then; but the bay and the inlet, with the fish and the crabs, and the ebbing and flowing tides, were there, very much the same, before Hendrik Hudson and his brave Dutchmen knew anything whatever about that corner of the world.

The Kinzer farm had always been a reasonably "fat" one, both as to size and quality, and the good people who lived on it had generally been of a somewhat similar description. It was, therefore, every way correct and becoming for Dabney Kinzer's widowed mother and his sisters to be the plump and hearty beings they were, and all the more discouraging to poor Dabney that no amount of regular and faithful eating seemed to make him resemble them at all in that respect.

Mrs. Kinzer excused his thinness to her neighbors, to be sure, on the ground that he was "such a growing boy;" but, for all that, he caught himself

wondering, now and then, if he would never be done with that part of his trials. For rapid growth has its trials.

"The fact is," he said to himself, one day, as he leaned over the north fence, "I'm more like Ham Morris's farm than I am like ours. His farm is bigger than ours, all 'round; but it's too big for its fences, just as I'm too big for my clothes. Ham's house is three times as large as ours, but it looks as if it had grown too fast. It hasn't any paint, to speak of, nor any blinds. It looks a good deal as if somebody'd just built it there and then forgot it and gone off and left it out-of-doors."

Dabney's four sisters had all come into the world before him, but he was as tall as any of them, and was frequently taken by strangers for a good two years older than he really was.

It was sometimes very hard for him, a boy of fifteen, to live up to what was expected of those two extra years.

Mrs. Kinzer still kept him in roundabouts; but they did not seem to hinder his growth at all, if that was her object in so doing.

There was no such thing, however, as keeping the four girls in roundabouts, of any kind; and, what between them and their mother, the pleasant and tidy little Kinzer homestead, with its snug parlor and its cozy bits of rooms and chambers, seemed to nestle away, under the shadowing elms and sycamores, smaller and smaller with every year that came.

It was a terribly tight fit for such a family, anyway; and, now that Dabney was growing at such a rate, there was no telling what they would all come to. But Mrs. Kinzer came, at last, to the rescue, and she summoned her eldest daughter, Miranda, to her aid.

A very notable woman was the widow. When the new railway cut off part of the old farm, she had split up the slice of land between the iron track and the village into "town lots," and had sold them all off by the time the railway company paid her for the "damage" it had done the property.

The whole Kinzer family gained visibly in plumpness that year,—except, perhaps, Dabney.

Of course, the condition and requirements of Ham Morris and his big farm, just over the north fence, had not escaped such a pair of eyes as those of the widow, and the very size of his great barn of a house finally settled his fate for him.

A large, quiet, unambitious, but well brought up and industrious young man was Hamilton Morris, and he had not the least idea of the good in store for him for several months after Mrs. Kinzer decided to marry him to her daughter Miranda. But all was soon settled. Dab, of course, had nothing to do with the wedding arrangements, and Ham's share was somewhat contracted. Not but what he was at the Kinzer house a good deal; nor did any of the other girls tell Miranda how very much he was in the way. He could talk, however, and one morning, about a fortnight before the day appointed, he said to Miranda and her mother:

"We can't have so very much of a wedding; your house is so small, and you've chocked it so full of furniture. Right down nice furniture it is, too; but there's so much of it. I'm afraid the minister'll have to stand out in the front yard."

"The house'll do for this time," replied Mrs. [Page 554] Kinzer. "There 'll be room enough for everybody. What puzzles me is Dab."

"What about Dab?" asked Ham.

"Can't find a thing to fit him," said Dab's mother. "Seems as if he were all odd sizes, from head to foot."

"Fit him!" exclaimed Ham. "Oh, you mean ready-made goods! Of course you can't. He'll have to be measured by a tailor, and have his new suit built for him."

"Such extravagance!" emphatically remarked Mrs. Kinzer.

"Not for rich people like you, and for a wedding," replied Ham; "and Dab's a growing boy. Where is he now? I'm going to the village, and I'll take him right along with me."

There seemed to be no help for it; but that was the first point relating to the wedding concerning which Ham Morris was permitted to have exactly his own way. His success made Dab Kinzer a fast friend of his for life, and that was something.

There was also something new and wonderful to Dabney himself in walking into a tailor's shop, picking out cloth to please himself, and being so carefully measured all over. He stretched and swelled himself in all directions, to make sure nothing should turn out too small. At the end of it all, Ham said to him:

"Now, Dab, my boy, this suit is to be a present from me to you, on Miranda's account."

Dab colored and hesitated for a moment; but it seemed all right, he thought, and so he came frankly out with:

"Thank you, Ham. You always was a prime good fellow. I'll do as much for you some day. Tell you what I'll do, then. I'll have another suit made, right away, of this other cloth, and have the bill for that one sent to our folks."

"Do it!" exclaimed Ham. "Do it! You've your mother's orders for that. She's nothing to do with my gift."

"Splendid!" almost shouted Dab. "Oh, but don't I hope they'll fit!"

"Vit?" said the tailor. "Vill zay vit? I dell you zay vit you like a knife. You vait und zee."

Dab failed to get a very clear idea of what the fit would be, but it made him almost hold his breath to think of it.

After the triumphant visit to the tailor, there was still a necessity for a call upon the shoe-maker, and that was a matter of no small importance. Dab's

feet had always been a mystery and a trial to him. If his memory contained one record darker than another, it was the endless history of his misadventures with boots and shoes. He and leather had been at war from the day he left his creeping clothes until now. But now he was promised a pair of shoes that would be sure to fit.

So the question of Dab's personal appearance at the wedding was all arranged between him and Ham; and Miranda smiled more sweetly than ever before upon the latter, after she had heard her usually silent brother break out so enthusiastically about him as he did that evening.

It was a good thing for that wedding that it took place in fine summer weather, for neither kith, kin, nor acquaintances had been slighted in the invitations, and the Kinzers were one of the "oldest families."

To have gathered them all under the roof of that house, without either stretching it out wider or boiling the guests down, would have been out of the question, and so the majority, with Dabney in his new clothes to keep them countenance, stood or sat in the cool shade of the grand old trees during the ceremony, which was performed near the open door, and were afterward served with the wedding refreshments, in a style that spoke volumes for Mrs. Kinzer's good management, as well as for her hospitality.

The only drawback to Dab's happiness that day was that his acquaintances hardly seemed to know him. He had had almost the same trouble with himself when he looked in the glass that morning.

Ordinarily, his wrists were several inches through his coat sleeves, and his ankles made a perpetual show of his stockings. His neck, too, seemed usually to be holding his head as far as possible from his coat collar, and his buttons had no favor to ask of his button-holes.

Now, even as the tailor had promised, he had received his "first fit." He seemed to himself, to tell the truth, to be covered up in a prodigal waste of nice cloth. Would he ever, ever grow too big for such a suit of clothes as that? It was a very painful thought, and he did his best to put it away from him.

Still, it was a little hard to have a young lady, whom he had known before she began to walk, remark to him: "Excuse me, sir, but can you tell me if Mr. Dabney Kinzer is here?"

"No, Jenny Walters," sharply responded Dab, "he isn't here."

"Why, Dabney!" exclaimed the pretty Jenny, "is that you? I declare, you've scared me out of a year's growth."

"I wish you'd scare me, then," said Dab. "Then my clothes would stay fitted."

Everything had been so well arranged beforehand, thanks to Mrs. Kinzer, that the wedding had no chance at all except to go off well. Ham Morris was rejoiced to find how entirely he was relieved of every responsibility.

"Don't worry about your house, Hamilton," the [Page 555] widow said to him the night before. "We'll go over there as soon as you and Miranda get away, and it'll be all ready for you by the time you get back."

"All right," said Ham. "I'll be glad to have you take the old place in hand. I've only tried to live in a corner of it. You don't know how much room there is. I don't, I must say."

Dabney had longed to ask her if she meant to have it moved over to the Kinzer side of the north fence, but he had doubts as to the propriety of it, and just then the boy came in from the tailor's with his bundle of new clothes.

CHAPTER II.

Hamilton Morris was a very promising young man, of some thirty summers. He had been an "orphan" for a dozen years, and the wonder was that he should so long have lived alone in the big square-built house his father left him. At all events, Miranda Kinzer was just the wife for him.

Miranda's mother had seen that at a glance, the moment her mind was settled about the house. As to that and his great, spreading, half-cultivated

farm, all either of them needed was ready money and management.

These were blessings Ham was now made reasonably sure of, on his return from his wedding trip, and he was likely to appreciate them.

As for Dabney Kinzer, he was in no respect overcome by the novelty and excitement of the wedding. All the rest of the day he devoted himself to such duties as were assigned him, with a new and grand idea steadily taking shape in his mind. He felt as if his brains, too, were growing. Some of his mother's older and more intimate friends remained with her all day, probably to comfort her for the loss of Miranda, and two or three of them, Dab knew, would stay to tea, so that his services would be in demand to see them safely home.

All day long, moreover, Samantha and Keziah and Pamela seemed to find themselves wonderfully busy, one way and another, so that they paid even less attention than usual to any of the ins and outs of their brother.

Dabney was therefore able, with little difficulty, to take for himself whatever of odd time he might require for putting his new idea into execution.

Mrs. Kinzer herself noticed the rare good sense with which her son hurried through with his dinner and slipped away, leaving her in undisturbed possession of the table and her lady guests, and neither she nor either of the girls had a thought of following him.

If they had done so, they might have seen him draw a good-sized bundle out from under the lilac-thicket in the back yard, and hurry down through the garden.

A few minutes more and Dabney appeared on the fence of the old cross-road leading down to the shore. There he sat, eying one passer-by after another, till he suddenly sprang from his perch, exclaiming: "That's just the chap. Why, they'll fit him, and that's more'n they ever did for me."

Dab would probably have had to search along the coast for miles before he could have found a human being better suited to his present charitable

purposes than the boy who now came so lazily down the road.

There was no doubt about his color, or that he was all over of about the same shade of black. His old tow trousers and calico shirt revealed the shining fact in too many places to leave room for a question, and shoes he had none.

"Dick," said Dabney, "was you ever married?"

"Married!" exclaimed Dick, with a peal of very musical laughter. "Is I married? No! Is you?"

"No," replied Dabney, "but I was mighty near it, this morning."

"Dat so?" asked Dick, with another show of his white teeth. "Done ye good, den. Nebber seen ye look so nice afore."

"You'd look nicer'n I do, if you were only dressed up," said Dab. "Just you put on these."

"Golly!" exclaimed the black boy. But he seized the bundle Dab threw him, and he had it open in a twinkling. "Anyt'ing in de pockets?" he asked.

"Guess

not," said Dab; "but there's lots of room."

"Say dar was!" exclaimed Dick. "But wont dese t'ings be warm!"

It was quite likely, for the day was not a cool one, and Dick never seemed to think of pulling off what he had on before getting into his unexpected present. Coat, vest, and trousers, they were all pulled on with more quickness than Dab had ever seen the young African display before.

"I's much obleeged to ye, Mr. Kinzer," said Dick, very proudly, as he strutted across the road. "On'y I dasn't go back fru de village."

"What'll you do, then?" asked Dab.

"S'pose I'd better go a-fishin'," said Dick. "Will de fish bite?"

"Oh, the clothes wont make any odds to them," said Dabney. "I must go back to the house."

And so he did, while Dick, on whom the cast-off garments of his white friend were really a pretty good fit, marched on down the road, feeling grander than he ever had before in all his life.

"That'll be a good thing to tell Ham Morris when he and Miranda come home again," muttered Dab, as he re-entered the house.

Late that evening, when Dabney returned from [Page 556] his final duties as escort to his mother's guests, she rewarded him with more than he could remember ever receiving of motherly commendation.

"I've been really quite proud of you, Dabney," she said to him, as she laid her plump hand on the collar of his new coat and kissed him. "You've behaved like a perfect gentleman."

"Only, mother," exclaimed Keziah, "he spent too much of his time with that sharp-tongued little Jenny Walters."

"Never mind, Kezi," said Dab. "She didn't know who I was till I told her. I'm going to wear a label with my name on it, when I go over to the village, to-morrow."

"And then you'll put on your other suit in the morning," said Mrs. Kinzer, "You must keep this for Sundays and great occasions."

When the morning came, Dabney Kinzer was a more than usually early riser, for he felt that he had waked up to a very important day.

"Dabney," exclaimed his mother, when he came in to breakfast, "did I not tell you to put on your other suit?"

"So I have, mother," replied Dab; "this is my other suit."

"That!" exclaimed Mrs. Kinzer.

"So it is!" cried Keziah.

"So it isn't," added Samantha. "Mother, that's not what he had on yesterday."

"He's been trading again," mildly suggested Pamela.

"Dabney," said Mrs. Kinzer, "what does this mean?"

"Mean!" replied Dabney, "Why, these are the clothes you told me to buy. The lot I wore yesterday were a present from Ham Morris. He's a splendid fellow. I'm glad he got the best of the girls."

That was a bad thing for Dabney to say, just then, for it was resented vigorously by the remaining three. As soon as quiet was restored, however, Mrs. Kinzer remarked:

"I think Hamilton should have consulted me about it; but it's too late now. Anyhow, you may go and put on your other clothes."

"My wedding suit?" asked Dab.

"No, indeed! I mean your old ones; those you took off night before last."

"Dunno where they are," slowly responded Dab.

"Don't know where they are?" repeated a chorus of four voices.

"No," said Dab. "Bill Lee's black boy had 'em on all yesterday afternoon, and I reckon he's gone a-fishing again to-day. They fit him a good sight better'n they ever did me."

If Dabney had expected a storm to come from his mother's end of the table, he was pleasantly mistaken, and his sisters had it all to themselves for a moment. Then, with an admiring glance at her son, the thoughtful matron remarked:

"Just like his father, for all the world. It's no use, girls. Dabney's a growing boy in more ways than one. Dabney, I shall want you to go over to the

Morris house with me after breakfast. Then you may hitch up the ponies, and we'll do some errands around the village."



DAB GIVES DICK HIS OLD CLOTHES.

Dab Kinzer's sisters looked at one another in blank astonishment, and Samantha would have left the table if she had only finished her breakfast.

Pamela, as being nearest to Dab in age and sympathy, gave a very admiring look at her brother's second "good fit," and said nothing.

Even Keziah finally admitted, in her own mind, that such a change in Dabney's appearance might have its advantages. But Samantha inwardly

declared war.

The young hero himself was hardly used to that second suit as yet, and felt anything but easy in it.

"I wonder," he said to himself, "what Jenny Walters would think of me now? Wonder if she'd know me?"

Not a doubt of it. But, after he had finished his breakfast and gone out, his mother remarked:

"It's really all right, girls. I almost fear I've been neglecting Dabney. He isn't a little boy [Page 557] any more."

"He isn't a man yet," exclaimed Samantha, "and he talks slang dreadfully."

"But then he does grow so!" remarked Keziah.

"Mother," said Pamela, "couldn't you get Dab to give Dick the slang, along with the old clothes?"

"We'll see about it," replied Mrs. Kinzer.

It was very plain that Dabney's mother had begun to take in a new idea about her son. It was not the least bit in the world unpleasant to find out that he was "growing in more ways than one," and it was quite likely that she had indeed kept him too long in roundabouts.

CHAPTER III.

Dick Lee had been more than half right about the village being a dangerous place for him with such an unusual amount of clothing over his ordinary uniform.

The very dogs, every one of whom was an old acquaintance, barked at him on his way home that night; and, proud as were his ebony father and mother, they yielded to his earnest entreaties, first, that he might wear his

present all the next day, and, second, that he might betake himself to the "bay," early in the morning, and so keep out of sight "till he got used to it."

The fault with Dab Kinzer's old suit, after all, had lain mainly in its size rather than its materials, for Mrs. Kinzer was too good a manager to be really stingy.

Dick succeeded in reaching the boat-landing without falling in with any one who seemed disposed to laugh at him; but there, right on the wharf, was a white boy of about his own age, and he felt a good deal like backing out.

"Nebber seen him afore, either," said Dick to himself. "Den I guess I aint afeard ob him."

The stranger was a somewhat short and thick-set but bright and active-looking boy, with a pair of very keen, greenish-gray eyes. But, after all, the first word he spoke to poor Dick was:

"Hullo, clothes! where are you going with all that boy?"

"I knowed it! I knowed it!" groaned Dick. But he answered, as sharply as he knew how: "I's goin' a-fishin'. Any ob youah business?"

"Where'd you learn to fish?" the stranger asked. "Down South? Didn't know they had any there."

"Nebbah was down Souf," was the surly reply.

"Father run away, did he?"

"He nebber was down dar, nudder."

"Nor his father?"

"T aint no business o' your'n," said Dick; "but we's allers lived right heah on dis bay."

"Guess not," replied the white boy, knowingly.

But Dick was right, for his people had been slaves among the very earliest Dutch settlers, and had never "lived South" at all. He was now busily getting one of the boats ready to push off; but his white tormentor went at him again with—

"Well, then, if you've lived here so long, you must know everybody."

"Reckon I do."

"Are there any nice fellows around here? Any like me?"

"De nicest young genelman 'round dis bay," replied Dick, "is Mr. Dab Kinzer. But he aint like you. Not nuff to hurt 'im."

"Dab Kinzer!" exclaimed the stranger. "Where did he get his name?"

"In de bay, I spect," said Dick, as he shoved his boat off. "Caught 'im wid a hook."

"Anyhow," said the strange boy to himself, "that's probably the sort of fellow my father would wish me to associate with. Only it's likely he's very ignorant."

And he walked away toward the village with the air of a man who had forgotten more than the rest of his race were ever likely to find out.

At all events, Dick Lee had managed to say a good word for his benefactor, little as he could guess what might be the consequences.

Meantime, Dab Kinzer, when he went out from breakfast, had strolled away to the north fence, for a good look at the house which was thenceforth to be the home of his favorite sister. He had seen it before, every day since he could remember; but it seemed to have a fresh and almost mournful interest for him just now.

"Hullo!" he exclaimed, as he leaned against the fence. "Putting up ladders? Oh yes, I see! That's old Tommy McGrew, the house-painter. Well, Ham's house needs a new coat as badly as I did. Sure it'll fit, too. Only it aint used to it any more'n I am."

"Dabney!"

It was his mother's voice, and Dab felt like "minding" very promptly that morning.

"Dabney, my boy, come here to the gate."

"Ham's having his house painted," he remarked, as he joined his mother.

"Is he?" she said. "We'll go and see about it."

As they drew nearer, however, Dabney discovered that carpenters as well as painters were plying their trade in and about the old homestead. There were window-sashes piled here and blinds there, a new door or so ready for use, with bundles of shingles, and other signs of approaching "renovation."

"Going to fix it all over," remarked Dab.

"Yes," replied his mother; "it'll be as good as new. It was well built, and will bear mending."

When they entered the house, it became more [Page 558] and more evident that the "shabby" days of the Morris mansion were numbered. There were men at work in almost every room.

Ham's wedding trip would surely give plenty of time, at that rate, and his house would be "all ready for him" on his return.

There was nothing wonderful to Dabney in the fact that his mother went about inspecting work and giving directions. He had never seen her do anything else, and he had the greatest confidence in her knowledge and ability.

Dabney noticed, too, before they left the place, that all the customary farm-work was going ahead with even more regularity and energy than if the owner himself had been present.

"Ham's farm'll look like ours, one of these days, at this rate," he said to his mother.

"I mean it shall," she replied, somewhat sharply. "Now go and get out the ponies, and we'll do the rest of our errands."

If they had only known it, at that very moment Ham and his blooming bride were setting out for a drive at the fashionable watering-place where they had made the first stop in their wedding tour.

"Ham?" said Miranda, "it seems to me as if we were a thousand miles from home."

"We shall be further before we get nearer," said Ham.

"But I wonder what they are doing there,—mother and the girls and dear little Dabney?"

"Little Dabney!" exclaimed Ham. "Why, Miranda, do you think Dab is a baby yet?"

"No, not a baby. But——"

"Well, he's a boy, that's a fact; but he'll be as tall as I am in three years."

"Will he ever be fat?"

"Not till after he gets his full length," said Ham. "We must have him at our house a good deal, and feed him up. I've taken a liking to Dab."

"Feed him up!" said Miranda, with some indignation. "Do you think we starve him?"

"No; but how many meals a day does he get?"

"Three, of course, like the rest of us; and he never misses one of them."

"I suppose not," said Ham, "I never miss a meal myself, if I can help it. But don't you think three meals a day is rather short allowance for a boy like Dab?"

Miranda thought a moment, but then she answered, positively: "No, I don't. Not if he does as well at each one of them as Dab is sure to."

"Well," said Ham, "that was in his old clothes, that were too tight for him. Now he's got a good loose fit, with plenty of room, you don't know how much more he may need. No, Miranda, I'm going to have an eye on Dabney."

"You're a dear, good fellow, anyway," said Miranda, "and I hope mother'll have the house all ready for us when we get back."

"She will," replied Ham. "I shall hardly be easy till I see what she has done with it."

CHAPTER IV.

"That's him!"

Dab was standing by the ponies, in front of a store in the village. His mother was making some purchases in the store, and Dab was thinking how the Morris house would look when it was finished, and it was at him the old farmer was pointing in answer to a question which had just been asked.

The questioner was the sharp-eyed boy who had bothered poor Dick Lee that morning.

At that moment, however, a young lady—quite young—came tripping along the sidewalk, and was stopped by Dab Kinzer with:

"There, Jenny Walters, I forgot my label!"

"Why, Dabney, is that you? How you startled me! Forgot your label?"

"Yes," said Dab; "I'm in another new suit to-day, and I want to have a label with my name on it. You'd have known me, then."

"But I know you now," exclaimed Jenny. "Why, I saw you yesterday."

"Yes, and I told you it was me. Can you read, Jenny?"

"Why, what a question!"

"Because, if you can't, it won't do me any good to wear a label."

"Dabney Kinzer," exclaimed Jenny. "There's another thing you ought to get?"

"What's that?"

"Some good manners," said the little lady, snappishly. "Think, of your stopping me in the street to tell me I can't read."

"Then you mustn't forget me so quick," said Dab. "If you meet my old clothes anywhere you must call 'em Dick Lee. They've had a change of name."

"So, he's in them, is he? I don't doubt they look better than they ever did before."

And Jenny walked proudly away, leaving her old playmate feeling as if he had had a little the worst of it. That was often the way with people who stopped to talk with Jenny Walters, and she was not as much of a favorite as she otherwise might have been.

Hardly had she disappeared before Dab was confronted by the strange boy.

"Is your name Dabney Kinzer?" said he.

"Yes, I believe so."

"Well, I'm Mr. Ford Foster, of New York."

"Come over here to buy goods?" suggested Dab. "Or to get something to eat?"

Ford Foster was apparently of about Dab's age,^[Page 559] but a full head less in height, so that there was more point in the question than there seemed to

be, but he treated it as not worthy of notice, and asked: "Do you know of a house to let anywhere about here?"

"House to let?" suddenly exclaimed the voice of Mrs. Kinzer, behind him, much to Dab's surprise. "Are you asking about a house? Whom for?"

If Ford Foster had been ready to "chaff" Dick Lee, or even Dab Kinzer, he knew enough to speak respectfully to the portly and business-like lady now before him.

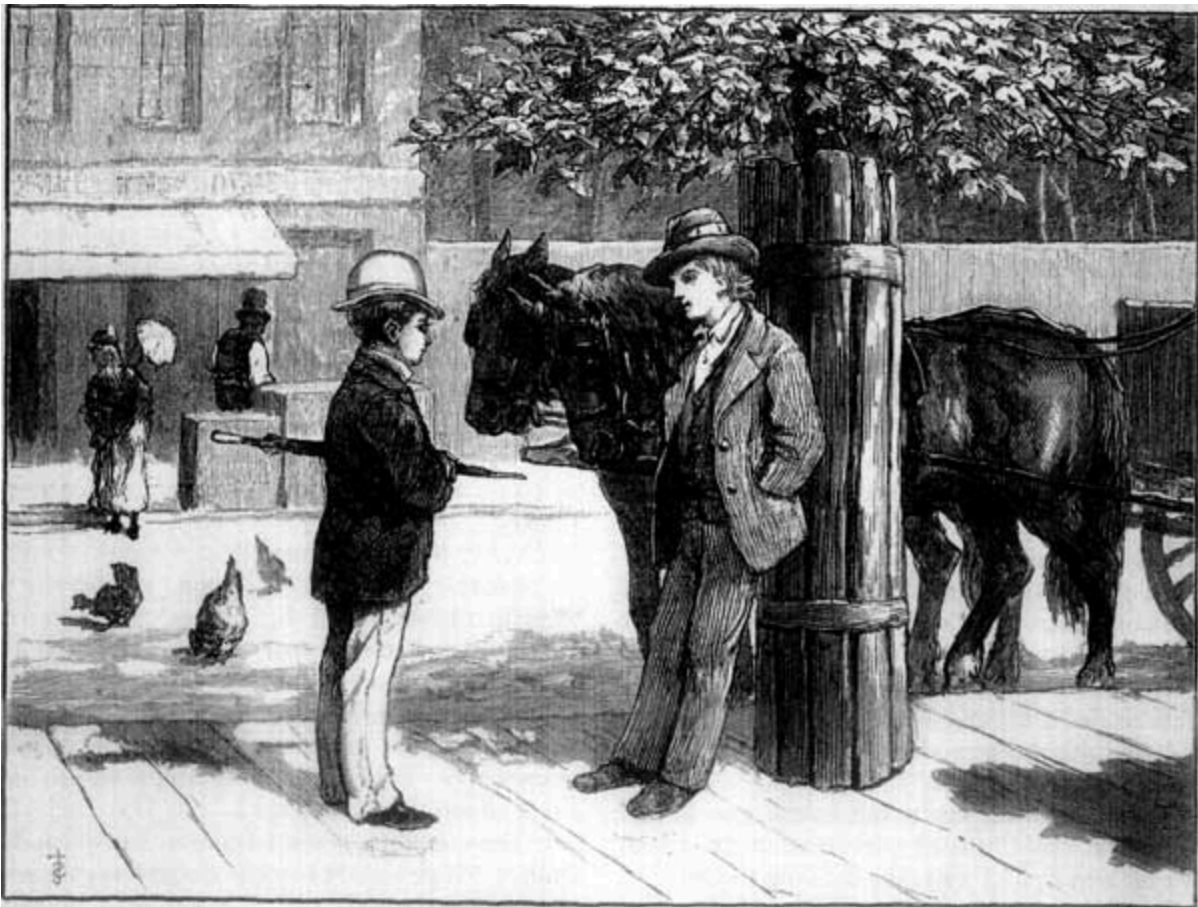

"IS YOUR NAME DABNEY KINZER?"

"Yes, madam," he said, with a ceremonious bow. "I wish to report to my father that I've found an acceptable house in this vicinity."

"You do!"

Mrs. Kinzer was reading the young gentleman through and through as she spoke, but she followed her exclamation with a dozen questions, and then wound up with:

"Go right home, then, and tell your father the only good house to let in this neighborhood will be ready for him next week, and he'd better see me at once. Get into the buggy, Dabney."

"A very remarkable woman!" muttered Ford Foster to himself as they drove away. "I must make some more inquiries."

"Mother," said Dabney, "you wouldn't let 'em have Ham's house?"

"No, indeed; but I don't mean to have our own stand empty." And, with that, a great deal of light began to break in on Dabney's mind.

"That's it, is it?" he said to himself, as he touched up the ponies. "Well, there'll be room enough for all of us there, and no mistake. But what'll Ham say?"

It was not till late the next day, however, that Ford Foster completed his inquiries. He took the afternoon train for the city, satisfied that, much as he knew before he came, he had actually learned a good deal more which was valuable.

He was almost the only person in the car. Trains going toward the city were apt to be thinly peopled at that time of day, but the empty cars had to be taken along all the same, for the benefit of the crowds who would be coming out, later in the afternoon and in the evening. The railway company would have made more money with full loads both ways, but it was well they did not have one on that precise train. Ford had turned over the seat in front of him, and stretched himself out with his feet on it. It was almost like lying down[Page 560] for a boy of his length, but it was the very best position he could have taken if he had known what was coming.

Known what was coming?

Yes, there was a pig coming.

That was all, but it was quite enough, considering what that pig was about to do. He was going where he chose, just then, and he chose not to turn out for the railway train.

"What a whistle!" Ford Foster had just exclaimed. "It sounds more like the squeal of an iron pig than anything else. I——"

But at that instant there came a great jolt and a shock, and Ford found himself suddenly tumbled, all in a heap, on the seat where his feet had been. Then came bounce after bounce and the sound of breaking glass, and then a crash.

"Off the track!" shouted Ford, as he sprang to his feet. "I wouldn't have missed it for anything, but I do hope nobody's killed."

In the tremendous excitement of the moment he could hardly have told how he got out of that car, but it did not seem ten seconds till he was standing beside the conductor and engineer, looking at the battered engine as it lay on its side in a deep ditch. The baggage car, just behind it, was broken all to pieces, but the passenger cars did not seem to have suffered very much, and nobody was badly hurt, as the engineer and fireman had jumped off in time.

"This train'll never get in on time," said Ford to the conductor, a little later. "How'll I get to the city?"

"Well," replied the railway man, who was not in the best of humors, "I don't suppose the city could do without you overnight. The junction with the main road is only two miles ahead, and if you're a good walker you may catch a train there."

Some of the other passengers, none of whom were very much hurt, had made the same discovery, and in a few minutes more there was a long, straggling procession of uncomfortable people marching by the side of the railway track, under the hot sun. The conductor was right, however, and nearly all of them managed to make the two miles to the junction in time.

Mr. Ford Foster was among the very first to arrive, and he was likely to reach home in very fair season in spite of the pig.

As for his danger, he had hardly thought of that, and he would not have missed so important an adventure for anything he could think of, just then.

It was to a great, pompous, stylish, crowded, "up-town boarding-house," that Ford's return was to take him. There was no wonder at all that wise people should wish to get out of such a place in such hot weather. Still, it was the sort of a home Ford Foster had been best acquainted with all his life, and it was partly owing to that that he had become so prematurely "knowing."

He knew too much, in fact, and was only too well aware of it. He had filled his head with an unlimited stock of boarding-house information, as well as with a firm persuasion that there was little more to be had,—unless, indeed, it might be scraps of such outside, knowledge as he had now been picking up over on Long Island.

In one of the great "parlor chambers" of the boarding-house, at about eight o'clock that evening, a middle-aged gentleman and lady, with a fair, sweet-faced girl of about nineteen, were sitting near an open window, very much as if they were waiting for somebody.

Such a kindly, motherly lady! She was one of those whom no one can help liking, after seeing her smile once, or hearing her speak. Whatever may have been his faults or short-comings, Ford Foster could not have put in words what he thought about his mother. And yet he had no difficulty in expressing his respect for his father, or his unbounded admiration for his pretty sister Annie.

"Oh, husband!" exclaimed Mrs. Foster, "are you sure none of them were injured?"

"So the telegraphic report said. Not a bone broken of anybody but the pig that got in the way."

"But how I wish he would come!" groaned Annie. "Have you any idea, papa, how he can get home?"

"Not clearly," said her father, "but you can trust Ford not to miss any opportunity. He's just the boy to look out for himself in an emergency."

Ford Foster's father took very strongly after the son in whose ability he expressed so much confidence. He had just such a square, active, bustling sort of body, several sizes larger, with just such keen, penetrating, greenish-gray eyes. Anybody would have picked him out, at a glance, for a lawyer, and a good one.

That was exactly what he was, and if any one had become acquainted with either son or father, there would have been no difficulty afterward in identifying the other.

It required a good deal more than the telegraphic report of the accident or even her husband's assurances, to relieve the motherly anxiety of good Mrs. Foster, or even to drive away the shadows from the face of Annie.

No doubt if Ford himself had known the state of affairs, they would have been relieved earlier; for even while they were talking about him he was already in the house. It had not so much as occurred to him that his mother would hear of the accident to the pig and the railway train until he himself should tell her, and so, he had made sure of his supper down-stairs, before reporting himself.^[Page 561] He might not have done it, perhaps, but he had come in through the lower way, by the area door, and that of the dining-room had stood temptingly wide open with some very eatable things ready on the table.

That had been too much for Ford, after his car-ride and his smash-up and his long walk. But now, at last, up he came, brimful of new and wonderful experiences, to be more than a little astonished by the manner and enthusiasm of his welcome.

"Why, mother!" he exclaimed, when he got a chance for a word, "you and Annie couldn't have said much more if I'd been the pig himself."

"The pig?" said Annie.

"Yes, the pig that stopped us. He and the engine went home to their families to-night."

"Don't make fun of it, Ford," said his mother, gently; "it's too serious a matter."

Just then his father broke in, almost impatiently, with, "Well, Ford, my boy, have you done your errand, or shall I have to see about it myself? You've been gone two days."

"Thirty-seven hours and a half, father," replied Ford, taking out his watch. "I've kept an exact account of my expenses. We've saved the cost of advertising."

"And spent it on railroading," said his father, with a laugh.

"But, Ford," asked Annie, "did you find a house?—a good one?"

"Yes," added Mrs. Foster, "now I'm sure you're safe, I do want to hear about the house."

"It's all right, mother," said Ford, confidently. "The very house you told me to hunt for. Neither too large nor too small, and it's in apple-pie order."

There were plenty of questions to answer now, but Ford was every way equal to the occasion. His report, in fact, compelled his father to look at him with an expression of face which very clearly meant, "That boy resembles me. I was just like him at his age. He'll be just like me at mine."

There was really very good reason to approve of the manner in which the young gentleman had performed his errand in the country, and Mr. Foster promptly decided to go over, in a day or two, and settle matters with Mrs. Kinzer.

(To be continued.)



MAKING READY FOR A CRUISE.

HOW WILLY WOLLY WENT A-FISHING.

BY S.C. STONE.

One day, on going fishing
Was Willy Wolly bent;
And, as it chanced a holiday,
Why, Willy Wolly went.



Now, Willy Wolly planned, you see,
To catch a speckled trout;
But caught a very different fish
From what he had laid out!

In view of all the fishes,—
Who much enjoyed the joke,
With many a joyous wriggle

And finny punch and poke,—

Young Willy Wolly, leaping [Page 563]

A fence with dire design,
Had carelessly left swinging
His fishing-hook and line.



How Willy Wolly did it,
He really could not tell,
But instantly he had his fish
Exceeding fast and well!

He hooked the struggling monster
Securely in the sleeve;
And, all at once, he found it time
His pleasant sport to leave;—

'T was not a very gamy fish^[Page 564]
For one so large and strong,
That Willy Wolly, blubbering,
Helped carefully along.

The giggling fishes crowded to
The river bank to look,
As Willy Wolly, captive, led
Himself with line and hook!



When Willy Wolly went, you see,
To catch a speckled trout,
Why, Willy Wolly caught *himself!*
And so the joke is out.

His mother saved that barbèd hook,
And sternly bid him now
No more to dare a-fishing go,
Until he has learned how!

CRUMBS FROM OLDER READING.

BY JULIA E. SARGENT.

III.—THOMAS CARLYLE.

"Shakespeare says we are creatures that look before and after. The more surprising, then, that we do not look around a little, and see what is passing under our very eyes."

So writes Thomas Carlyle.

Although he politely says "we," when speaking of people in general, that part of the "we" known as Thomas Carlyle certainly keeps his eyes wide open. So wide, indeed, that much that is disagreeable comes under his notice, as always will be the case with those who choose to see everything.

I once watched the round, red sun as it crimsoned the sparkling waters in which it seemed already sinking. When, at last, I turned my dazzled eyes away, all over lake and sky I saw dancing black suns. Perhaps it is through dwelling long on one idea that Carlyle sees only spots of blackness on what others call clear sky. The great want of that foggy, smoky city where he lives is pure, health-giving light, and this we also miss in his writings, which, like London, have not enough sunshine.

But, whatever people may say, when Carlyle speaks the world is quite ready to listen.

Who is Thomas Carlyle?

He is a Scotchman, a philosopher, an essayist, an historian, a biographer, and an octogenarian.

What has he done to be so famous?

He has written twenty books. But you might live to be an octogenarian yourself without meeting twenty persons who would have read them all. It would not be a hard matter, though, to find those who have read one of his books twenty times; perhaps this very green-covered book with "Sartor Resartus" on the back.

What does it mean, and what is it all about?

It means "The Tailor Re-tailored," and Carlyle says it is a book about clothes. But you need not look for fashion-plates; there are none there. You will hear nothing about new costumes; for this book is full of Carlyle's own thoughts, clothed in such words that you will surely enjoy the book.

Hear how he tells us that nothing that we do is really "of no matter," as we so often think:

"I say, there is not a red Indian hunting by Lake Winnepeg can quarrel with his squaw but the whole world must smart for it: will not the price of beaver rise?"

You think it would not make much difference if the price of beaver should rise? Let us look at the matter. First, Mr. B. Woods, the trader, must pay a larger price for his beaver, and therefore must sell for more to the firm of Bylow & Selhi. These shrewd gentlemen do not intend to lose on their purchase, so they pay a less sum to Mr. Maycup, the manufacturer. This reduction in his income causes Mr. Maycup to curtail family expenses. So his subscription to ST. NICHOLAS is discontinued, and the youthful Maycups are overwhelmed with grief, because of that unfortunate quarrel which raised the price of beaver.

But why should the price change because of that?

Really, Mr. Carlyle should answer you. Perhaps the Indian in his quarrel forgets to set his traps, or the whole neighborhood may become so interested in the little affair that beavers are forgotten.

"Were it not miraculous could I stretch forth my hand and clutch the sun? Yet thou seest me daily stretch forth my hand and clutch many a thing and swing it hither and thither. Art thou a grown baby, then, to fancy that the miracle lies in miles of distance, or in pounds avoirdupois of weight; and not to see that the true miracle lies in this, that I can stretch forth my hand at all?"

What is it that Carlyle thinks so wonderful? See how quietly my hand rests on this table. Why should it move any more than the table on which it rests? Is not Carlyle right when he calls every movement of my hand a wonder? You never thought of it before? That is as Carlyle says: "We do not look around a little and see what is passing under our very eyes."

It was this great old man whose hand brushed the clinging mud from a crust of bread, and placed it on the curbstone, for some dog or pigeon, saying, "My mother taught me never to waste anything."

Here is a word for those who are always planning what great things they will do—who think so much *about* doing that no time is left *for* the doing:

"The end of man is an action, and not a thought, though it were the noblest."

Now, for our final crumb, comes a well-clothed thought that I like better than quarreling Indians or familiar wonders. It is the reason why selfish people are never really happy. Carlyle thinks they have only themselves to blame, for he says:

"Always there is a black spot in our sunshine; it is even, as I said, *the shadow of ourselves.*"



JACK-IN-THE-PULPIT.

Hurrah for June!—bright, rosy June! "Joy rises in me like a summer's morn!" as one of those pleasant people, the poets, has said.

Let everybody be glad! But most of all, you, my youngsters! The month properly belongs to you. Don't I know? Wasn't it set apart by Romulus, ages and ages ago, especially for the young people, or "Juniors," as they then were called? And hasn't their name stuck to it ever since? Yes, indeed! So, be as merry as you can, my chicks; but, with all your fun and frolic, be thankful, and make June weather all about you. June time—any time—is full of joy when hearts, brimming over with thankfulness, carry cheer to other hearts, making

"A noise like of a hidden brook
In the leafy month of June,
That to the sleeping woods all night
Singeth a quiet tune,"—

like the little stream that bubbles by the foot of our meadow.

Now to business. First comes a letter about

A ROPE OF EGGS.

Brooklyn, N.Y.
My Dear Jack-in-the-Pulpit: I know about a rope of eggs, and I will tell you. It is in Japan.
The eggs are plaited and twisted into ropes made from straw, and so it is safe and easy to
handle them. Just think how queer it would seem to buy eggs by the yard!

AMY M.

CONVERSATION BY FISTICUFFS.

After being flurried by clouds of paragrams about sphymographs, and phonographs, and pneumatic telegraphs, and scores of other extraordinary scientific ways of communication, I'm not in the least surprised to learn that ants converse by one tapping another's head.

I'm told that an Englishman named Jesse once put a small caterpillar near an ants' nest, and watched. Soon an ant seized it; but the caterpillar was too heavy to be moved by one ant alone, so away he ran until he met another ant. They stopped for a few moments, during which each tapped the other's head with his feelers in a very lively manner. Then they both hurried off to the caterpillar, and together dragged it home.

A HORSE THAT LOVED TEA.

Dear Jack-in-the-Pulpit: This is a true story of Mary's horse. He was just as Roxbury, Mass. black as a coal all over, except a pretty white star on his forehead.

Once in two or three weeks Mary had him take tea with her and her little brother and sisters. She went to the stable where he lived with Kate and Nell, two pretty twin ponies, and said to him:

"Come, Jack! Don't you want some, tea?"

At that, he came right up to her, and found out the buttons on her dress, and tried to pull them off, and then untied her apron strings.

"Now, Jack," Mary said, "tea is all ready. Come along!"—and he followed her along the walk to the back door and up the three steps into the house.

What a clatter his iron shoes made along the entry to the dining-room!

Harry and Annie and Fanny rushed out, crying:

"Oh, mamma! Here's Jack coming to tea!"

Then mamma filled a large bowl with tea, put in plenty of milk and three or four pieces of white sugar (for Jack had a sweet tooth), and cut a slice of bread into pieces, and put them on a plate, with a doughnut or piece of gingerbread. And Mary said:

"Now, Jack, come up to the table!"

You see, he was too big to sit in a chair; but he came close up to the table and stood there, and drank his tea without slopping any over, and ate up his bread and cake. And when he had done, what do you think he did? Why, he went up to the piano that stood in a corner of the room and smelled the keys, and looked round at Mary. That was to ask her to play him a tune before he went home.

Then she said, "Oh, you dear Jack! I know what you want!" And she sat down and played some merry tune, while he pricked up his ears and put his nose down close to her fingers, he was so pleased. Then he rubbed her shoulder with his nose, and Mary played another tune for him.

"Now, Jack," mamma said, "you've had a nice time; but you must go back to your stable. Kate and Nell will miss you if you stay longer."

Then Mary opened the dining-room door, and Jack followed her down the long entry and out to the stable, just like a dog.—Yours truly, B.P.

TONGUES WHICH CARRY TEETH.

You've heard of folks with biting tongues, I dare say, and very disagreeable they are, no doubt, though, of course, they do not actually bite with their tongues. However, there really is an unpleasant fellow whose tongue carries twenty-six thousand eight hundred teeth! A capital one for biting, you'd suppose. He is nothing but a slug, though, and his army of teeth only scrape, not bite, I'm told. Then, too, there is a sort of cousin of his, a periwinkle, who has a long ribbon-like tongue, armed with six hundred crosswise rows of hooks, about seven in a row.

You can make sure of these surprising facts, my dears, with the aid of patience and a microscope.

DIZZY DISTANCES.

The other day, one of the school-children said to a chum, "The Little Schoolma'am told us this morning that some parts of the ocean are more than four miles deep!"

That's easy to say, thought I, but try to think it, my dear! Fix on a place four miles away from you, and then imagine every bit of that distance stretching down under you, instead of straight before you. Perhaps in this way you may gain an idea of the depth of the ocean; but just consider the height of the air—which, I'm told, is a sort of envelope about the earth—more than nine times the depth of the ocean! Yet, what a wee bit of a way toward the moon would those thirty-six miles take us! And from the earth to the moon is only a very little step on the long way to the sun.

Oh dear! Let's stop and take a breath! Why did I begin talking of such dizzy distances?

LAND THAT INCREASES IN HEIGHT.

Here is a letter in answer to the Little School-ma'am's question which I passed over to you in April, and it raises such startling ideas, that, may be, you'd do well to look farther into the matter:

DEAR JACK: We suppose that the Little Schoolma'am and her writers on Greenland will concede its accidental discovery by Gunnbjorn, as narrated by Cyrus Martin, Jr., in his "Vikings in America" [ST. NICHOLAS, Vol. III., page 586]. We have always thought Iceland appropriately named, and Greenland the reverse.

And now about that question of temperature. If portions of Greenland are colder than formerly, may it not be because less heat comes through its crust from subterranean fires, as well as because the surface is constantly gaining in height, as some report?—Very truly yours,
NED AND WILL WHITFORD.

THE ANGERED GOOSE.

The picture of which you here have an engraving formed at first a kind of panel of a wall, and occupied a space beneath one of the cartoons of Raphael, the great Italian painter, whose grand picture of "The Transfiguration" is thought to be his chief work. This panel-picture, also, was painted by Raphael, as some say, though others think it may be the work of one of his pupils.

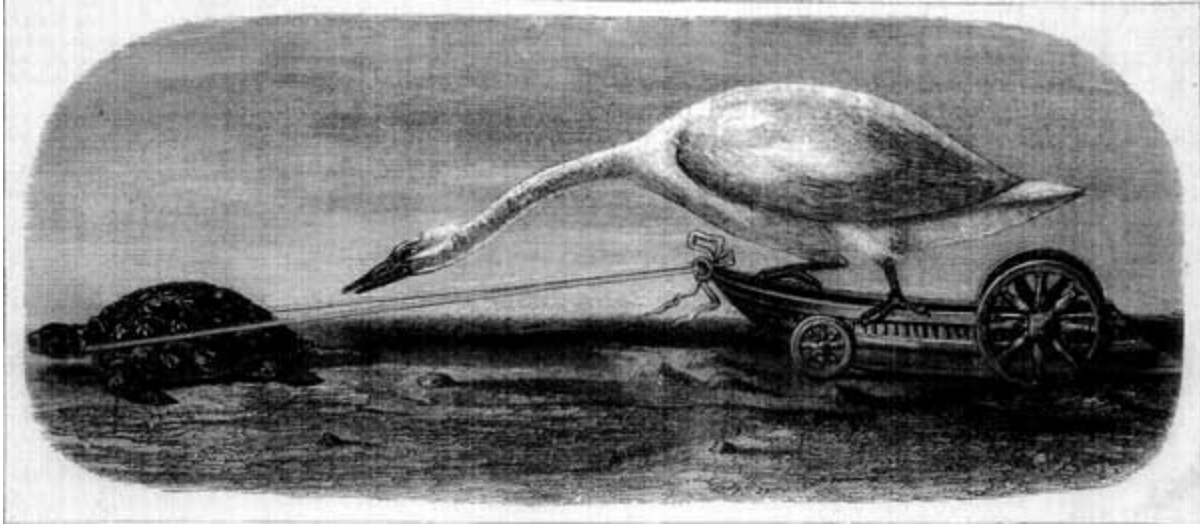

"THE ANGERED GOOSE."

A curious thing about the picture is this: the goose is so excited, and scolding its tortoise so angrily for going slowly, that it has forgotten its own wings, when, if it would only use them, it could fly to its journey's end long before the tortoise could crawl there. Now, there are other two-legged geese who let themselves get angered and excited easily, and so lose many chances of serving others and helping themselves. Perhaps you may know some of them.

That is what the Deacon says; but, for my part, I never knew a goose that *hadn't* two legs.

A CITY UNDER THE WATER.

In past ages, as the Deacon once told some of his older boys in my hearing, the people of some parts of Europe used to live above the surfaces of lakes, in huts built on spiles driven into the water.

Well, now I hear that some one has found, under the water of Lake Geneva, a whole town, with about two hundred stone houses, a large public square, and a high tower; and, from the looks of the town, the shape of the houses,

and the way the stones are cut, some say that the place must have been built more than two thousand years ago!

Now, I can understand how men were able to live in the way the Deacon described, but it strikes me that this other story has something in it that's harder to swallow than water.

Who ever heard of men living in cities under the water, as if they were fishes?

REFLECTION.

The Red School-house.

MY DEAR JACK-IN-THE-PULPIT: Many thanks for putting into your April sermon the picture and letter which I sent to you. Now, I must let you know about the explanations that some of your bright chicks have given.

Arnold Guyot Cameron, S.E.S., O.C. Turner, Louise G. Hinsdale, and the partners E.K.S. and M.G.V. guessed the right word, which is "Reflection"; and, of course, it needed some "reflection" to find it out. The lady in the picture is absorbed in "reflection" upon something she has been reading in her book; but, besides this, the water is represented as sending back a "reflection" of nearly every other object in the picture.

Several others of your youngsters wrote, but they were not so fortunate in their attempts. "Mignon" suggests the word "Heads," for the reason that the guessing has given employment to many heads. John F. Wyatt thinks that "Beautiful" is the word. Alfred Whitman, C.H. Payne, and Nellie Emerson, though writing from three places far apart, agree in giving the word "Reverie" as their notion of the right one. George A. Mitchell thinks it is "Study"; Arthur W. James guesses "Meditation"; and Hallie quietly hints "Calm." "P.," however, believes that the word is "Misrepresented," which he inclines to write, "Miss represented." But Nathalie B. Conkling puts forward the exclamation "Alas!" as the proper solution, spelling it "A lass."

Now, puns are not always good wit, and these two are not puns of the best kind; but they, as well as the other guesses, show that your chicks have lively minds, able to see a thing from more than one point of view, even although their conjectures do not hit the very center of the mark in every instance. I am much obliged to them all for their letters, and to you, dear Jack, for your kindness.—Sincerely your friend, THE LITTLE SCHOOLMA'AM.

"FIDDLE-DIDDLE-DEE!"

Little Davie ran through the garden,—a great slice of bread and butter in one hand, and his spelling-book in the other. He was going to study his lesson for to-morrow.

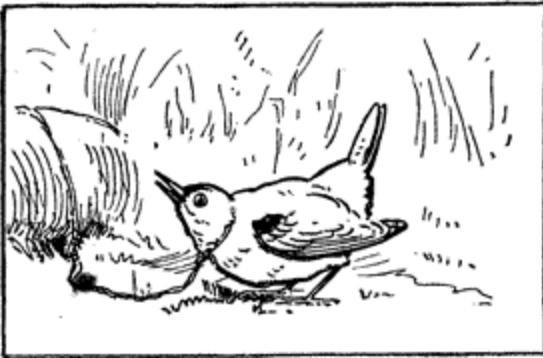

You could not imagine a prettier spot than Davie's "study," as he called it. It was under a great oak-tree, that stood at the edge of a small wood. The little boy sat down on one of the roots and opened his book.

"But first," thought he, "I'll finish my bread and butter."

So he let his book drop, and, as he ate, he began to sing a little song with which his mother sometimes put the baby to sleep. This is the way the song began:

"I bought a bird, and my bird pleased me;
I tied my bird behind a tree;
Bird said——"

"Fiddle-diddle-dee!" sang something, or somebody, behind the oak. Davie looked a little frightened, for that was just what he was about to sing in his song. But he jumped up and ran around to the other side of the tree. And there was a little brown wren, and it had a little golden thread around its neck, and the thread was tied to a root of the big tree.

"Hello!" said Davie, "was that you?"

Now, of course Davie had not expected the wren to answer him. But the bird turned her head on one side, and, looking up at Davie, said:

"Yes, of course it was me! Who else did you suppose it could be?"

"Oh yes!" said Davie, very much astonished. "Oh yes, of course! But I thought you only did it in the song!"

"Well," said the wren, "were not you singing the song, and am not I in the song, and what else could I do?"

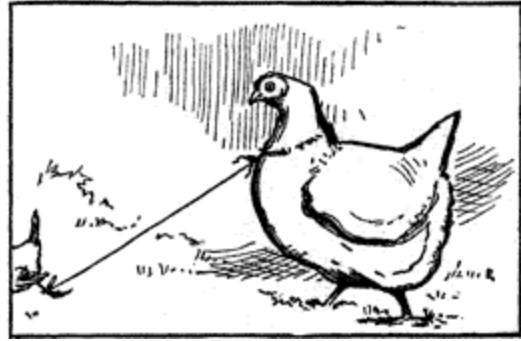

"Yes, I suppose so," said Davie.

"Well, go, then," said the wren, "and don't bother me."

Davie felt very queer. He stopped a moment, but soon thought that he must do as he was bid, and he

began [Page 569] to sing again:

"I bought a hen, and my hen pleased me;
I tied my hen behind a tree;
Hen said——"

"Shinny-shack! shinny-shack!" interrupted another voice, so loudly that Davie's heart gave a great thump, as he turned around. There, behind the wren, stood a little Bantam hen, and around her neck was a little golden cord that fastened her to the wren's leg.

"I suppose that was you?" said Davie.

"Yes, indeed," replied the hen. "I know when my time comes in, in a song. But it was provoking for you to call me away from my chicks."

"I?" cried Davie. "I didn't call you!"

"Oh, indeed!" said the Bantam. "It wasn't you, then, who were singing 'Tied my hen,' just now! Oh no, not you!"

"I'm sorry," said Davie. "I didn't mean to."

"Well, go on, then," said the little hen, "and don't bother."

Davie was so full of wonder that he did not know what to think of it all. He went back to his seat, and sang again:

"I had a guinea, and my guinea pleased me;
I tied my guinea behind a tree——"

But here he stopped, with his mouth wide open; for up a tiny brown path that led into the wood, came a little red man about a foot high, dressed in green, and leading by a long yellow string a plump, speckled guinea-hen! The little old man came whistling along until he reached the Bantam, when he fastened the yellow string to her leg, and went back again down the path, and disappeared among the trees.

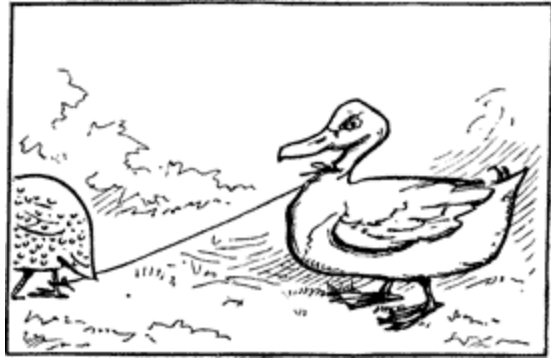

Davie looked and wondered. Presently, the guinea stretched out her neck and called to him in a funny voice:

"Why in the world don't you go on? Do you think I want to wait all day for my turn to come?"

Davie began to sing again: "Guinea said——"

"Pot-rack! pot-rack!" instantly squeaked the speckled guinea-hen.

Davie jumped up. He was fairly [Page 570] frightened now. But his courage soon came back. "I'm not afraid," he said to himself; "I'll see what the end of this song will be!"—and he began to sing again:

"I bought a duck, and my duck pleased me;
I tied my duck behind a tree;
Duck said——"

"Quack! quack!" came from around the oak. But Davie went on:

"I bought a
dog, and the
dog pleased
me;
I tied my dog
behind a tree;
Dog said——"



"Bow-wow!" said a little curly dog, as Davie came around the spreading roots of the tree. There stood a little short-legged duck tied to the guinea's leg, and to the duck's leg was fastened the wisest-looking Scotch terrier, with spectacles on his nose and a walking-cane in his paw.

The whole group looked up at Davie, who now felt perfectly confident. He sat down on a stone close by, and continued his song:

"I had a horse, and my horse pleased me;
I tied my horse behind a tree."

Davie stopped and looked down the little brown path. Then he clapped his hands in great delight; for there came the little old man leading by a golden bridle a snow-white pony, no bigger than Davie's Newfoundland dog.

"Sure enough, it is a boy!" said the pony, as the old man tied his bridle to the dog's hind leg, and then hurried away. "I thought so! Boys are always bothering people."

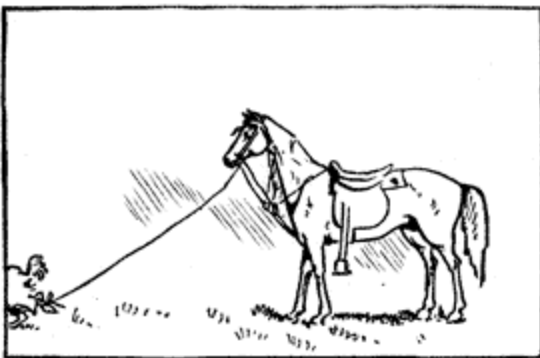

"Who are you, and where did you all come from?" asked delighted Davie.

"Why," said the pony, "we belong to the court of Her Majesty the Queen of the Fairies. But, of course, when the song in which any of the court voices are wanted, is sung, they all have to go."

"I'm sure I'm very sorry," said Davie. "But why haven't I ever seen you all before?"

"Because," said the pony, "you have never sung the song down here before." And then he added: "Don't you think, now that we are all here, [Page 571] you'd better sing the song right end first, and be done with it?"

"Oh, certainly!" cried Davie, "certainly!" beginning to sing.

If you could but have heard that song! As Davie sang, each fowl or animal took up its part, and sang it, with its own peculiar tone and manner, until they all joined in.

"I had a horse, and my horse pleased me;
I tied my horse behind a tree.
Horse said, 'Neigh! neigh!'
Dog said, 'Bow-wow!'
Duck said, 'Quack! quack!'
Guinea said, 'Pot-rack! pot-rack!'
Hen said, 'Shinny-shack! shinny-shack!'
Bird said, 'Fiddle-diddle-dee!'"

Davie was overjoyed. He thought he would sing it all over again. But just then he was sure that his mother called him.

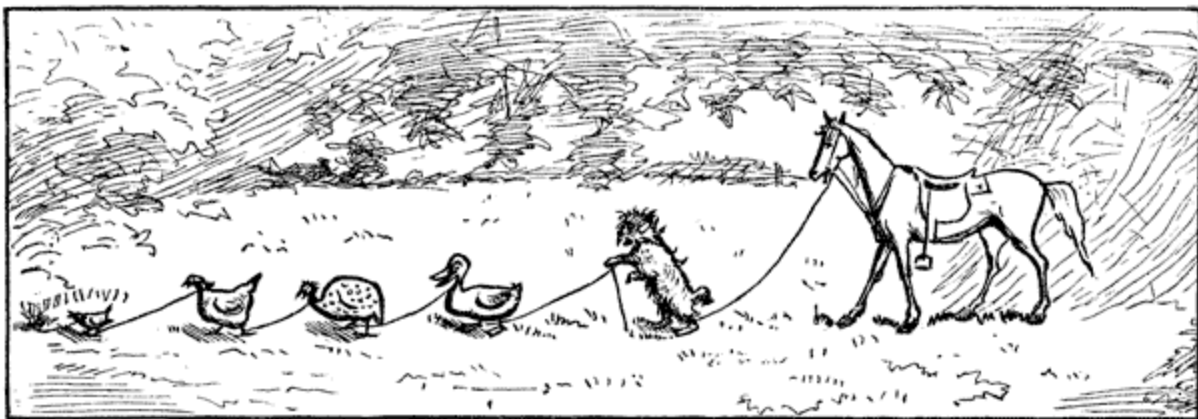

"Wait a minute!" he said to his companions. "Wait a minute! I'm coming back! Oh, it's just like a fairy-tale!" he cried to himself, as he bounded up the garden-walk. "I wonder what mother'll think?"

But his mother said she had not called him, and so he ran back as fast as his legs would carry him.

But they were all gone. His speller lay on the ground, open at the page of his lesson; a crumb or two of bread was scattered about; but not a sign of the white pony and the rest of the singers.

"Well," said Davie, as he picked up his book, "I guess I wont sing it again, for I bothered them so. But I wish they had stayed a little longer."



THE LETTER-BOX.

A BRAVE GIRL.

One summer day, in Union square, New York City, a beautiful deed was done, which our frontispiece tells so well as almost to leave no need of words. A poor blind man started to cross the street just as a car was rapidly approaching. He heard it coming, and, growing confused, stood still—his poor, blind face turned helplessly, pathetically up, as if imploring aid. Men looked on heedlessly, regardless of his danger, or the voiceless appeal in his sightless eyes.

Suddenly, from among the passers-by, a young girl sprang to his side, between him and the great horses which were so near they almost touched her, laid her dainty hand on his, and led him safely over the street, and with gentle words that brought a smile to his withered old face, set him safely on his way.

It was a brave, kindly act, and one may be sure it was neither the first nor the last, of the brave girl who did it.

If Charles Dudley Warner had never been a boy, it would have been impossible for him to write the very interesting little volume he calls "Being a Boy," for it is evident that he knows well, from experience, all that he writes about. It may be that many of our young readers have seen this book, for it has already reached several editions; but if there are any of them who have not read it, and who take an interest in the life of boys who are born, and brought up, and have fun, and drive oxen, and go fishing, and turn grindstones, and eat pumpkin-pie, and catch wood-chucks, all on a New England farm, they would do well to get the book and read it.

If any of those who read it are boys on a farm in New England, they will see themselves, as if they looked in a mirror; and if any of them are city boys or girls, or live in the South or West, or anywhere in the world but in

New England, they will see what sort of times some of the smartest and brightest men in our country had, before they grew up to be governors, book-writers, and other folks of importance.

There is a particular reason why readers of ST. NICHOLAS should see this book, for in it they will meet with some old friends.

Williamsburgh, L.I.

DEAR ST. NICHOLAS: I read in the May "Letter-Box" your answer to Stella G. about long and short words. It reminded me of what I read once about Count Von Moltke, the great German general. The writer described him as "the wonderful silent man who knows how to hold his tongue in eight different languages."—Yours truly,

WILLIE, M.D.

Santa Fé, N.M.

DEAR ST. NICHOLAS: The donkeys here are called "burros." They are very tame, and do not get frightened at anything. A few days ago, the boys in our school tied a bunch of fire crackers to the tail of one, and fired them off. We all thought he would be very frightened at the noise, but he just walked off and began eating grass. My brother Barry had one of these little burros, when we were in Texas, and every evening he would go to a lady's house for something to eat, although he had more than he could eat at home; and if she did not come to the window soon, he would bray as loudly as he could, and she would have to come out and give him something, even if it was only a lump of sugar. Good-bye,—From, your affectionate friend,

BESSIE HATCH.

Coldwater, N.Y.

DEAR ST. NICHOLAS: Having read in the March number an account of the "Great Eastern," I thought perhaps your readers would like to hear something of the history of her captain, which I read a short time ago.

When he was a little boy, he went to sea. As he left home, his mother said: "Wherever you are, Jamie, whether on sea or land, remember to acknowledge your God. Promise me that you will kneel down every morning and night and say your prayers, no matter whether the sailors laugh at you or not."

Jamie gave his promise, and soon he was on shipboard, bound for India. They had a good captain; and, as several of the sailors were religious men, no one laughed at the boy when he knelt down to pray.

On the return voyage, however, some of the former sailors having run away, their places were filled by others, and one of these proved to be a very bad fellow. When he saw little Jamie kneeling down, this wicked sailor went up to him, and, giving him a sound box on the ear, said, "None of that here, sir!"

Another seaman, who saw this, although he himself swore sometimes, was indignant that the child should be so cruelly treated. He told the man to come up on deck and he would give him a thrashing. The challenge was accepted, and the well-deserved beating was duly bestowed. Both then returned to the cabin, and the swearing man said, "Now, Jamie, say your prayers, and if he dares to touch you, I will give him another dressing."

The next night, Jamie was tempted to say his prayers in his hammock. The moment that the friendly sailor saw Jamie get into his hammock without first saying his prayers, he hurried to the spot and, dragging him out, said, "Kneel down at once, sir! Do you think I am going to fight for you, and you not say your prayers, you young rascal?" During the whole voyage back to London this same sailor watched over the boy as if he were his father, and every night saw that he said his prayers.

Jamie soon began to be industrious, and during his spare hours studied his books; he learned all about ropes and rigging, and became familiar with latitude and longitude. Some years after, he became captain of the "Great Eastern." On returning to England after a successful voyage, Queen Victoria bestowed upon him the honor of knighthood, and the world now knows him as Sir James Anderson.

MABEL R.

B.P.R.—Perhaps the little book called "Album Leaves," by Mr. George Houghton, published by Estes & Lauriat, will help you to some verses suitable to be written (sic) in autograph albums.

Mobile, Ala.

DEAR ST. NICHOLAS: The "that" question in your recent numbers brings to mind some "thats" I had when I went to school long years ago, and which some of your young grammarians may never have seen. I would like to have them, especially C.P.S., of Chicago, parse them.

E.S.F.

Now that is a word which may often be joined,
For that that may be doubled is clear to the mind,
And that that that is right, is as plain to the view
As that that that that we use is rightly used too;
And that that that that that line has in it, is right,
And accords with good grammar, is plain in our sight.

DEAR ST. NICHOLAS: I want to tell you about my aunt Hattie. She is only nine years older than I am, being twenty-one, and seems more like a sister than an aunt. When she was about fifteen she was thrown from her pony and hurt her spine, so that she hasn't taken a step since.

But in spite of her great suffering she is the brightest, happiest one in the house, brimful and running over with fun and spirits. Papa calls her our sunbeam, and no one can grumble when they see how patiently and cheerfully she bears her pain. Her bright face and merry laugh will cure the worst case of "blues." She wants me to tell you how much she enjoys ST. NICHOLAS. It is a great comfort to her, and helps to pass away many an hour of pain and loneliness when I am at school and mamma is busy. She says she doesn't know what she could do without it.

Auntie says you must make allowance for what I say of her as I am a partial judge; but she *is* the dearest, best auntie in the world, and I'm not the only one who thinks so. Everybody loves her, and I shall be satisfied if I ever learn to be half as good and patient and unselfish as she is. I don't see how she can be so good and patient and happy when she has to lie still year after year and suffer so much, I should get cross and fret about it, for I can't bear to be sick a day. But she never thinks of her own troubles, but is so afraid she will make us care or trouble. When the pain is very bad she likes to hear music or poetry. It soothes her better than anything else. Whittier's poem on "Patience," is a favorite with her, and so is Mrs. Browning's "Sleep."—Ever your true friend,

ALLIE BERTRAM.

Salem, Mass.

DEAR ST. NICHOLAS: I want to tell you about my little turtle. I got him up in the country last summer, and have had him about six months. I keep him in a bowl of water, with a shell in it. In summer I feed him with flies, and in winter I give him pieces of cooked meat about the size of a fly. My turtle's shell is nearly round, and he is small enough to be put in a tumbler, and then he can turn round as he likes. I named him "Two-forty" (a funny name), because, when you put him down, he stands still, looks around a minute, and then starts off on a run,—Your friend and reader,

JOHNNY P. WILLIS.

Camp Grant, Arizona.

DEAR ST. NICHOLAS: Your coming every month fills us with delight. We cannot wait to read you separately, so mamma reads you aloud after the lamps are lighted, the first evening you are here. Papa lays aside his pen to listen, just like any boy, and so we all enjoy your pages at once. I have one little sister, but no brother.^[Page 573] We live in camp, in far-away Arizona; and, although the "buck-board" brings the mail in every other day, it takes a long while for a letter to come from the East.

There is a pet deer here. He comes out to "guard mounting" on the parade-ground, and trots after the band when the guard passes in review. Every one

is kind to him; even the dogs know they must not chase him.—Your true friend,

MOLLIE GORDON.

New Brunswick, N.J.

DEAR ST. NICHOLAS: I would like to tell you of the nice times that the country children have, although they have no parks. In summer they can go on picnics, and they have a nice garden to play in. And most of the children have little gardens of their own to plant things in,—one for flowers and the other for vegetables. Then, in the winter-time, they can go coasting, sliding and skating; then, last but not least, sleigh-riding on the lovely, pure white snow.

I, for one, would not be a city child. If I lived in the city, I could not have my old pet hen. Good-by, dear ST. NICHOLAS.—From your friend—

MATHILDE WEYER.

P.S.—I have a cat by the name of Pussy Hiawatha.

Covington, Ohio.

DEAR ST. NICHOLAS: Would you like to know how I came to get you? I worked for you. My brother made a bank for me out of a cigar-box, and said if I put ten cents into it every week, I could begin taking you in November. That was in March. Sometimes, I could not get the ten cents, but I made it up the next week, and more, too, if I could; and before July, I had more than enough to pay for you. After that, I saved nearly enough to buy me a suit of clothes. I am working for you for another year. My age is twelve. —From your constant reader,

W.H. PERRY.

The following is sent to us from Josie C.H., aged eleven years, as her own composition:

SOME THINGS WHICH WE EXPECT IN YEARS TO COME.

Some boys, when they go to school, expect to learn. When they are a little older, they expect to go to college; and then, to learn trades and professions, and to become men. The farmer, when he plants his seed in the spring, expects a harvest. The merchant, when he buys his goods, expects to sell them at a profit. The student expects to become a lawyer, minister, etc. All boys expect to become men. We often expect things that never happen, but what we expect we cannot always get; yet we can try for them, which is a good rule to go by.

THE TRUE STORY OF "MARY'S LITTLE LAMB."

Saratoga Springs, N.Y.

DEAR ST. NICHOLAS: I want to tell you what I read lately in a newspaper about Mary and her lamb. Mary herself is now a delightful old lady of threescore and ten, and this is her story:

"I was nine years old, and we lived on a farm. I used to go out to the barn every morning with father, to see the cows and sheep. One cold day, we found that during the night twin lambs had been born. You know that sheep will often disown one of twins, and this morning one poor little lamb was pushed out of the pen into the yard. It was almost starved, and almost frozen, and father told me I might have it if I could keep it alive. So I took it into the house, wrapped it in a blanket, and fed it on peppermint and milk all day. When night came, I could not bear to leave it, for fear it would die. So mother made me up a little bed on the settle, and I nursed the poor little thing all night, feeding it with a spoon, and by morning it could stand. After this, we brought it up by hand, until it learned to love me very much, and would stay with me wherever I went, unless it was tied. I used, before going to school in the morning, to see that the lamb was all right, and securely fastened for the day.

"Well, one morning, when my brother Nat and I were all ready, the lamb could not be found, and, supposing that it had gone out to pasture with the cows, we started on. I used to be very fond of singing, and the lamb would

follow the sound of my voice. This morning, after we had gone some distance, I began to sing, and the lamb hearing me, followed, and overtook us before we got to school. As it happened, we were early; so I went in very quietly, and took the lamb into my seat, where it went to sleep, and I covered it up with my shawl. When the teacher and the rest of the scholars came, they did not notice anything amiss, and all was quiet until my spelling-class was called. Hardly had I taken my place when the patter of little hoofs was heard coming down the aisle, and the lamb stood beside me ready for its word. Of course, the children all laughed, and the teacher laughed too, and the poor creature had to be turned out-of-doors. But it kept coming back, and at last had to be tied in the wood-shed until school was out. Now, that day, there was a young man in the school, John Roulston by name, who had come as a spectator. He was a Boston boy and son of a riding-school master, and was fitting for Harvard College. He was very much pleased over what he saw in our school, and a few days after gave us the first three verses of the song. How or when it got into print, I don't know.

"I took great care of my pet, and would curl its long wool over a stick, Finally, it was killed by an angry cow. I have a pair of little stockings, knitted of yarn spun from the lamb's wool, the heels of which have been raveled out and given away piecemeal as mementoes."—Yours truly,

J.M.D.

Bolinas, Cal.

DEAR ST. NICHOLAS: Were the "Arabian Nights" written by an Englishman or translated from the Arabic? In either case can you tell us the name of the author?—Yours sincerely,

ESTHER R. DE PERSE AND JIMMIE MOORE.

The "Arabian Nights" were collected and translated into English by Edward William Lane, an Englishman; but no one ever has found out where or by whom the tales were first told. On page 42 of ST. NICHOLAS for November, 1874 (the first number), is an article on the subject by Mr. Donald G. Mitchell, which you would do well to read.

Geneva, Switzerland.

DEAR ST. NICHOLAS: Perhaps some of your American readers have visited this far-away city, and even attended school here. Pupils come here for schooling from all parts of the world,—from America, Cuba, England, Germany, Russia, Greece, and even from Egypt. But many of the ST. NICHOLAS children never have been here; so I will tell them about the country and the people.

In the first place, Switzerland is a republic, with president and vice-president, as in the United States, but chosen every year. Switzerland is made up of twenty-two cantons, or states, each of which has two representatives; and, besides these, there are 128 members of the National Assembly, and seven members of the Federal Council, each of which last is chosen once in three years. The country is only one-third as large as the State of New York, being 200 miles long and 156 broad; and two-thirds of it is composed of lofty mountains or deep ravines. The people are apparently such lovers of law and order as to need no rulers at all. I think there must be propriety in the air they breathe. They have honest faces, and honesty beams out of their clear blue eyes. The school-boy even, instead of stopping to throw stones or climb fences or wrestle with another boy, walks along to school, at eight o'clock in the morning, with his square hair-covered satchel on his back, as orderly as if he were the teacher setting an example to his pupils. The laborers, in blouse-frocks of blue or gray homespun, make no noise, no confusion. All is done quietly, orderly and correctly; each one knows his duty and does it.

Although Berne is the capital, Geneva is the largest city; and I think if you could see it as it is, with grand snow-capped mountains at both sides, the clear blue lake,—not always blue, for sometimes it is green, and then the blue Rhone can be distinctly seen flowing through it,—the pretty green parks and gardens, clean streets, and oddly dressed people, you would think, as I do, that it is a very nice place to be in.

There are several little steamers which ply on the lake, and numberless little sail and row boats, and beautiful white swans, with tiny olive-colored cygnets, swimming and diving for food. On the banks of the rapid river,

which leaves the lake at the city, are the wash-houses—a great curiosity. But my letter is getting too long, so I must stop.—Yours truly,

S.H. REDFIELD.

Easton, Pa.

DEAR ST. NICHOLAS: I send you an acrostic which I have made, and I hope you will print it.—Yours truly,

B.

ACROSTIC.

My first has a heart that has ne'er throbb'd with pity;
My next has strong arms, but ne'er strikes for the right;
My third has a head, but is not wise or witty;
My fourth, a neat foot, but in country or city
Is never seen walking, by day or by night;
My fifth, with a mouth that is surely capacious
Enough for a lion, is never voracious.
Guess from these five initials my whole, if you can;
'Tis a path ever used, yet untrodden by man.

Ans. Orbit. Oak, Reel, Barrel, Iambic, Tunnel.

CITY CHILDREN'S COUNTRY REST.

Brooklyn, E.D.

DEAR ST. NICHOLAS: Here is news to do your heart good. Last summer, a Brooklyn lady, who herself has been bed-ridden and in pain for many years, felt very sorry for the children of the tenement houses, who are unable to get relief or a chance to enjoy the fresh air and bright sunlight of the country. She longed to help them, and said so to Mr. P., a clergyman in northern Pennsylvania. He spoke of it to his congregation, and asked them if they would invite some of the poor city children to visit their farm-houses

and cottages for a week or so; and they gladly said they would, and told him he might bring along as many as he could get to come. This generous reply[Page 574] he told to the lady, and she let others know, and the result was that, although late in the season, more than sixty children from the poorest neighborhoods of Brooklyn—pale, deformed, city-worn, and ill-fed—spent a happy fortnight in the country.

The children were ferreted out, and their parents persuaded. They were then taken to the railroad depot, and there given in charge of Mr. P., who went with them, and sorted them among his people; and, when the time was up, brought them back, and turned them over to us at the depot. Then we took them to their homes. The total expense of carrying all the children there and back in three lots was about \$180, and more money could have been had if it had been wanted. In fact, the minute the subject was broached every hearer wanted to help. The railroad company charged only half fares, and the employés got to know Mr. P. and his batches of children, and did all they could to make things easy and cheerful for them.

I can fancy how glad you would have been, dear old ST. NICHOLAS, to see the happy, hearty, bright-eyed boys and girls that came home in place of the pale-faced, dead-and-alive children that left two weeks before! They talked of nothing but the good times they had had. One little fellow, thinking to surprise us, said, "I seen a cow!" All of them fared well, and particularly enjoyed the "good country milk." When they came back, many wore better clothes than they had gone in, and all were laden with good things for the home folks. One boy carried under each arm a "live" chicken,—special gifts for his mother!

Now, if some of your readers in the country follow the example of these Pennsylvania people, they will know what it is to be downright happy; for every person who has had anything to do with this enterprise feels happy about it, and longs to do it again, and more besides.—Yours truly,

C.B.

ANSWERS TO MR. CRANCH'S POETICAL CHARADES, published on page 406 of the April number, were received, before April 18, from Neils E. Hansen, C.W.W., Arnold Guyot Cameron, Helen and Frank Diller, "Sadie," "Marshall," Emma Lathers, Arthur W.

James, Louise G. Hinsdale, Ada C. Okell, E.K.S. and M.G.V., "Sunnyside Seminary," "Persephone," M.W.C., Genevieve Allis and Kittie Brewster, Florence Stryker, "Cosey Club," Mary and Willie Johnson, and Jeanie A. Christie.

ERRATUM.—The answer to No. 23 in "Presidential Discoveries" is "More" (Sir Thomas), not "William Henry," as given in the May number.

ANSWERS TO PUZZLES in the April number were received, before April 18, from R.H. Marr, Grace Sumner, "Prebo," Marion Abbot, Maxwell W. Turner, Willie W. Cooper, "Cosey Club," Samuel J. Holmes, "Three Sisters," Charles G. Todd, W.M., M.E. Adams, Mamie G.A., W. Thomas, Jeanie A. Christie, T. Bowdoin, Robert M. Webb, Allie Bertram, Willie Wilkins, Maggie Simon, Kitty P. Norton, M.W. Collet, Jay Benton, "Kaween," Morris M. Turk, Leonie Giraud, Catherine Cook, Willie B. Dess, Willie Cline, Frances M. Griffiths, Nellie J. Towle, "Isola," Mary C. Warren, Florence I. Turrill, Charles Fritts, "Angeline," Sam Cruse, John V.L. Pierson, "Ollie;" Tillie Powles and May Roys; Tyler Redfield, Grace A. Jarvis, Bennie Swift; Sarah Duffield and "No Name" and Constance F. Grand-Pierre; "Romeo and Juliet," "Jupiter," O.C. Turner, Jessie D. Worstell, Melly Woodward, R. Townsend McKeever, Eleanor N. Hughes, Ben Merrill; Annie and Lucy Wollaston; William Eichelberger and John Cress; "Clover-leaf and Pussy-willow," Alice Getty, Herbert D. Utley; Bertha and Carl Hefenstein and Estella Lohmeyer; C. Speiden and M.F. Speiden; Angeline O., May Filton, "Winnie," Maggie J. Gemmill, Jennie McClure, "X.Y.Z.," Neils E. Hansen, Clara B. Dunster, Bessie L. Barnes, Willie B. McLean, Bessie T., Lauretta V. Whyte, Hattie M. Heath; Charles W. Hutchins and Abbie F. Hutchins; Belle Murray, Harry A. Garfield; Helen and Frank Diller; Gertrude A. Pocock, Helena W. Chamberlain, "Al Kihall," Wm. F. Tort, "Lizzie and Anna," Kittie Tuers, Taylor Goshorn, Emma Lathers, "Marshall," Arthur W. James, Otto A. Dreier, "O.K.," Ada B. Raymond, "Seymour-Ct.," "Three Cousins," "Hallie," Alice Lanigan, Alfred Whitman, "Golden Eagle;" E.K.S. and M.G.V.; H.B. Ayers, Fred Chittenden; William McKinley Cobb and Howell Cobb, Jr.; Katie Hackett and Helen Titus; "35 E. 38th St.," W.D. Utley, Mary Lewis Darlington, Louisa L. Richards, James Barton Longacre, Nellie Emerson, Chas. B. Ebert, Jennie A. Carr, W.H. Wetmore, Mattie Olmsted; Arthur W. Hodgman, E.H. Hoeber, A.H. Peirce; Kittie Brewster and Genevieve Allis; Fannie B. Bates, Louise Eggleston, Florence Stryker, Hattie H. Doyle, Mattie Doyle, Mabel Chester, Alice N. Dunn. A.R., Mary F. Johnson, M. Alice Chase, Alice Anderson, Bessie T. Hosmer, "Heath Hill Club," Anna E. Mathewson, I. Sturges, Addie B. Tiemann, Harriet A. Clark, Clarence H. Young, B.P. Emery, Victor C. Sanborn, "Persephone," Eddie Vultee; "M.," Staten Island; Fred M. Pease, Cyrus C. Clarke, Geo. J. Fiske; and George H. Nisbett, of London, England.

Correct solutions of all the puzzles were received from Arnold Guyot Cameron, "Bessie and her Cousin," Louise G. Hinsdale, Lucy C. Johnson; and L.M. and Eddie Waldo.

THE RIDDLE-BOX.

EASY BEHEADINGS.

The whole, most animals possess; behead it, and transpose, and there will appear an emblem of grief; behead again, and see what all men have; behead and curtail, and find an article.

J.F.S.

ACCIDENTAL HIDINGS.

Find concealed in the following quotations three names for

METRICAL COMPOSITIONS.

"As hope and fear alternate chase
Our course through life's uncertain race."—*Scott*.

"Trained to the chase, his eagle eye
The ptarmigan in snow could spy."—*Scott*.

"Well-dressed, well-bred,
Well-equipped, is ticket good enough."—*Cowper*.

Find concealed in the following quotations three names for

PORTIONS OF TIME.

"From better habitations spurned,
Reluctant dost thou rove."—*Goldsmith*.

"As ever ye heard the greenwood dell
On morn of June one warbled swell."—*Queen's
Wake*.

"Each spire, each tower and cliff sublime,
Was hooded in the wreathy rime."—*Hogg*.

MELANGE.

1. Behead a plant, and leave a friend. 2. Curtail the plant, and give a pungent spice. 3. Syncopate the plant, and find an envelope. 4. Behead the spice, and leave affection. 5. Syncopate and transpose the friend, and find learning. 6. Behead the envelope, and leave above. 7. Syncopate and transpose the envelope, and give the inner part. 8. Transpose above, and find to ramble. 9. Syncopate to ramble, and leave a wild animal. ISOLA.

EASY CLASSICAL ACROSTIC.

My first is in deaf, but not in hear;
My second in doe, and also in deer;
My third is in May, but not in June;
My fourth is in song, but not in tune;
My fifth is in house, and also in shed;
My sixth is in cot, but not in bed;
My seventh is in chair, but not in stool;
My eighth is in lake, but not in pool;
My ninth is in pencil, and also in ink;
My tenth is in blue, but not in pink;
My eleventh is in dish, but not in pan;
My whole was a Greek and a well-spoken man.

ANNAN.

ENIGMA.

I am a common adage frequently used by good housewives, and am composed of twenty-two letters.

My 9 15 3 8 16 22 is pertaining to the place of birth. My 10 20 19 14 are things used to cook with. My 6 1 5 is a domestic animal. My 11 21 is a preposition. My 18 17 13 12 is to appear. My 7 4 2 is a pronoun.

BESSIE.

[Page 575]

ANAGRAMS.

Each anagram is formed from a single word, and a clue to the meaning of that word is given after its anagram.

1. A dry shop; rambling composition. 2. I clean rum; belonging to number. 3. Poet in dread; the act of making inroads. 4. Oxen are set; clears from blame. 5. Gin danger; displacing.

CYRIL DEANE.

PICTORIAL PUZZLE



What animal, besides the dog and the cat, is to be found in the above picture?

EASY DIAMOND PUZZLE.

1. A vowel. 2. A fairy. 3. Change. 4. Not many. 5. A consonant.

WILLIE F.

CHARADE.

I.

My first, a god once worshiped, now fills a lowly place,
Though sometimes raised to favor by the wayward human
race.

II.

My second, a bold captain, leads a goodly company,
Whose numbers march in columns, like knights of chivalry.
They serve us at our bidding, yet we are in their power,
And the weapons that they carry may wound us in an hour.
It grandly leads the ages, as their cycles onward roll,
But stoops to lend its presence to my shadowy, fearful
whole.
It lives in ancient romance, it floats upon the air,
And flower-deck'd May without it would not be half so fair.

III.

My third holds humble office, a servant at your will,
But an instrument of torture if 'tis not used with skill.
Beauty before her mirror studies its use with care,
And deigns, perchance, to choose it an ornament to wear.

IV.

Consider, all ye people, what my strange whole may be;
'Tis gloomy, dark and awful, and full of mystery.
Ponder the tales of ages, of human sin and woe,
Turn to historic pages, if you its name would know.
E'en kings their heads have rested, a-weary of the crown,
Upon its curious couches, though not of silk or down.
The stately seven-hilled city may boast her ancient birth,
But this was old and hoary ere she had place on earth.
Some tremble when they see it; some its secrets would
explore,
And, peering through its shadows, they seek its mystic lore.

A.M.W.

NUMERICAL PUZZLE.

A boy named 1 2 3 4 5 6 7 8 9 10 thought it singular he should become such a monster as a 1 2 3 4 6 7 8 9 10 by dropping the first letter of his surname.

C.D.

FOUR-LETTER SQUARE-WORD.

The base is a title. Fill the blanks in the following sentence with words which can be arranged in order, as they come, to form a word-square:

The (1)—— made an (2)—— of his minstrel, and yet he himself could not tell one (3)—— from another, or distinguish a dirge from a (4)——.

B.

EASY CROSS-WORD ENIGMA.

1. In road, but not in street;
2. In hunger, not in eat;
3. In inn, but not in tavern;
4. In grot, but not in cavern.

The whole is the name of one of the United States.

R.L. M'D.

METAGRAM.

Whole, (1) I am to beat; change my head, and I become, in succession, (2) stouter, (3) final, (4) substance, (5) to sprinkle, (6) to rend, and (7) a terrier of a much prized kind.

A.C. CRET.

EASY ACROSTIC.

My first is in can, but not in may;
My second in opera, not in play;
My third is in shine, but not in bright;
My fourth is in string, but not in kite;
My fifth is in tea, but not in coffee;
My sixth in candy, also in taffy;
My seventh is in rain, but not in hail;
My eighth is in bucket, but not in pail;
My ninth is in ice, but not in snow;
My tenth is in run, but not in go;
My eleventh is in hop, but not in run;
My twelfth in powder, but not in gun;
My thirteenth is in bell, but not in ring;
My fourteenth is in scream, but not in sing.
My whole is a noted city of Europe.

GOLD ELSIE.

BLANK WORD-SYNCOPATIONS.

Fill the first blank, in each sentence, with a certain word; the second, with a word taken out of the word chosen for the first blank; and the third with the letters of that word which remain after filling the second blank.

1. On the —— we first played ——, and then we all began to ——.

2. While —— on the wharf, we saw a vessel come into ——, which made us —— again.

3. The game of —— I will —— you play, if you will show me the —— to the fair.

CYRIL DEANE.

CHARADE.

My first embodies all despair;
My second fain my first would flee,
Yet, flying to my whole, full oft
Flies but to life-long misery.

Still Holy Writ doth plainly show;
My whole, though causing, cureth woe.

M. O'B.D.

TRANSPOSITIONS OF PROPER NAMES.

1. At ——, Fla., may be obtained —— —— for washing purposes.
2. Are not the public —— small in the State of ——?
3. In —— you may not see —— —— ——, though you certainly will see many in Pennsylvania.
4. Amid the mountains of —— there is doubtless many a —— ——.
5. Having occasion to visit the city of ——, to my surprise I —— —— except a few worn-out —— ——.
6. If you wish to find or to —— —— -trees, you need not go to——.
7. When in —— City I saw an old —— ——, which was quite a relic.
8. In the city of —— the cooks surely know how to —— ——.
9. ——, my brother, —— the falsehood by giving it a flat ——.
10. My aunt —— planted a rose-bush —— —— —— allotted to fruit trees.

W.

SQUARE-WORD.

1. Sour fruit. 2. Imaginary. 3. To immerse. 4. A large bird. 5. Unconscious rest.

B.

ADDITIONS.

1. Add some liquor to a spirit, and make to fix on a stake. 2. Add something belonging to animals to the animals themselves, and make a lantern. 3. Add sharp to a girl's name, and make a kind of cloth. 4. Add an era to a vegetable, and make a boy-servant. 5. Add a boy's name to a cave, and make a foreign country. 6. Add anger to a serpent, and make to long after.

LABYRINTH.

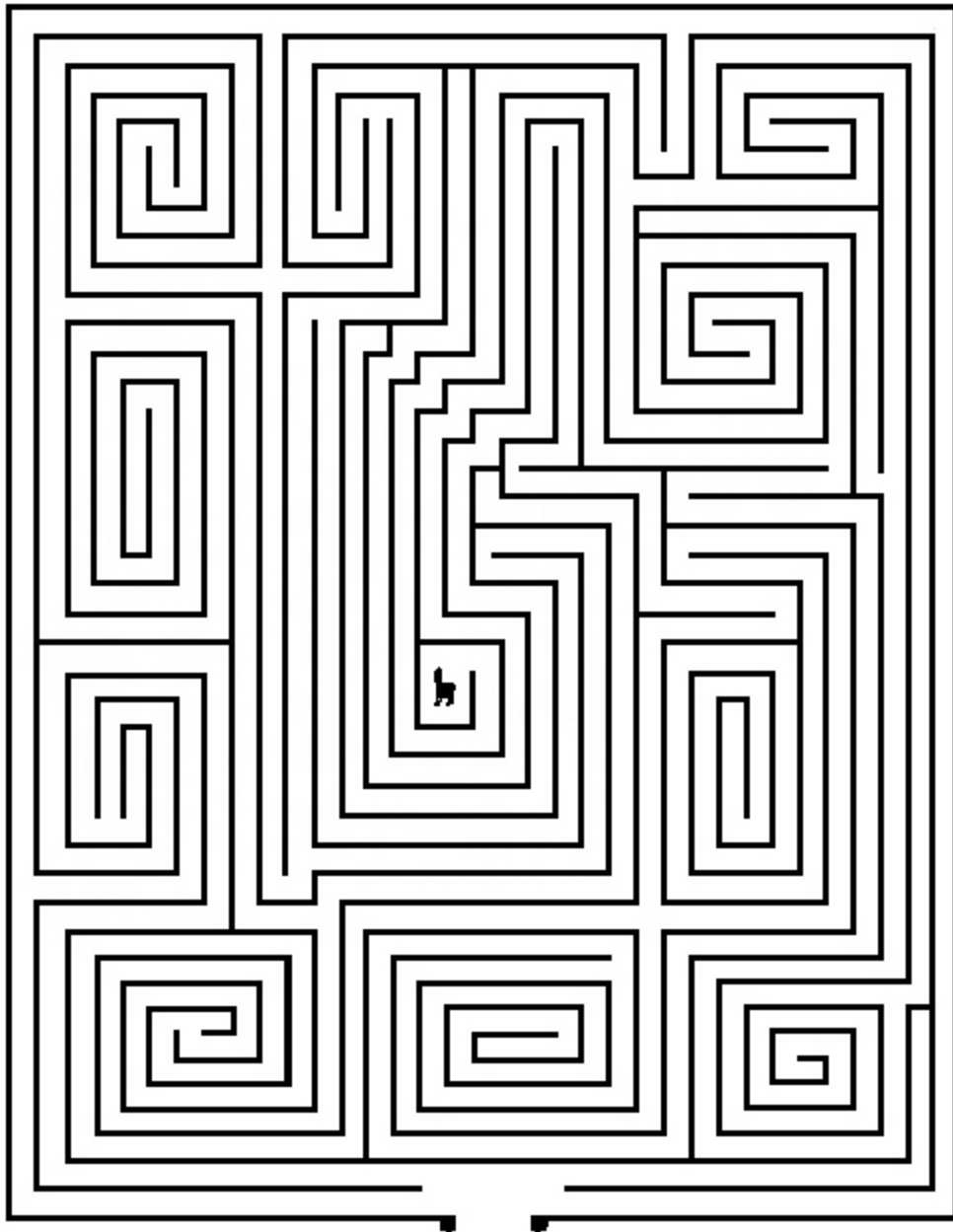

"Trace a way to the center of this labyrinth without crossing a line."

ANSWERS TO PUZZLES IN MAY NUMBER.

HOUR-GLASS PUZZLE.—Centrals: Greyhound. Across: Alligator. 2. Adoring. 3. Enemy. 4. Dye. 5. H. 6. Pop. 7. Elude. 8. Evangel. 9. Amendable.

BLANK APOCOPES.—1. Rafters, raft. 2. Rushlight, rush. 3. Larder, lard. 4. Scarlet, scar.

FRAME PUZZLE.—

	F			G			
	R			R			
H	E	A	D	B	A	N	D
	G			D			
	R			U			
C	H	A	P	L	A	I	N
	N			T			
	T			E			

EASY BEHEADINGS.—1. Beat, eat. 2. Candy, Andy. 3. She, he; your, our. 4. Table, able. 5. Pink, ink. 6. Scent, cent. 7. Brain, rain. 8. Orange, range. 9. Skate, Kate. 10. Helm, elm. 11. Crow, row. 12. Hash, ash. 13. Bowl, owl. 14. Scare, care. 15. Brush, rush.

EASY TRIPLE ACROSTIC.—Primals, Crow; centrals, Bear; finals, Gnat, 1. ComBinG. 2. ReverbEratioN. 3. OmAhA. 4. WoRsT.

HIDDEN FRENCH SENTENCE.—Ma ville de pierre,—"My city of stone," or "My city of Peter;" *i.e.* St. "Peter's-burg." ["Pierre" means "Peter" as well as "stone."]

PICTORIAL ANAGRAM PROVERB PUZZLE.—"It is good to be merry and wise."

THREE EASY SQUARE-WORDS.—

1—	P	O	E	2—	F	I	R	3—	L	A	W
	O	R	E		I	R	E		A	G	E
	E	E	L		R	E	D		W	E	D

EASY ENIGMA.—Diamond.

REVERSIBLE DOUBLE DIAMOND AND CONCEALED WORD-SQUARE.

Perpendiculars, Revel; horizontals, Lever. Word-square: 1. Ten. 2. Eve. 3. Net.

EASY SYNCOPATIONS.—1. Brass, bass. 2. Bread, bead. 3. Chart, cart. 4. Clove, cove. 5. Crane, cane. 6. Farce, face. 7. Heart, hart. 8. Horse, hose. 9. Mouse, muse. 10. Peony, pony.

PICTORIAL TRANSPOSITION PUZZLES.—1. Entitles (ten tiles). Raja (ajar). 3. Palm (lamp). 4. Satyr (trays). 5. Causer (saucer).

EASY SQUARE-WORD.—1. Balm. 2. Aloe. 3. Lore. 4. Meek.

EASY DIAMOND.—1. W. 2. Nag. 3. Water. 4. Gem. 5. R.

[For the names of those who sent answers to puzzles in the April number, see the "Letter-Box," page 574.]



*** END OF THE PROJECT GUTENBERG EBOOK ST. NICHOLAS
MAGAZINE FOR BOYS AND GIRLS, VOL. 5, NO. 08, JUNE 1878 ***

Updated editions will replace the previous one—the old editions will be renamed.

Creating the works from print editions not protected by U.S. copyright law means that no one owns a United States copyright in these works, so the Foundation (and you!) can copy and distribute it in the United States without permission and without paying copyright royalties. Special rules, set forth in the General Terms of Use part of this license, apply to copying and distributing Project Gutenberg™ electronic works to protect the PROJECT GUTENBERG™ concept and trademark. Project Gutenberg is a registered trademark, and may not be used if you charge for an eBook, except by following the terms of the trademark license, including paying royalties for use of the Project Gutenberg trademark. If you do not charge anything for copies of this eBook, complying with the trademark license is very easy. You may use this eBook for nearly any purpose such as creation of derivative works, reports, performances and research. Project Gutenberg eBooks may be modified and printed and given away—you may do practically ANYTHING in the United States with eBooks not protected by U.S. copyright law. Redistribution is subject to the trademark license, especially commercial redistribution.

START: FULL LICENSE

THE FULL PROJECT GUTENBERG™ LICENSE

PLEASE READ THIS BEFORE YOU DISTRIBUTE OR USE THIS WORK

To protect the Project Gutenberg™ mission of promoting the free distribution of electronic works, by using or distributing this work (or any other work associated in any way with the phrase “Project Gutenberg”), you agree to comply with all the terms of the Full Project Gutenberg License available with this file or online at www.gutenberg.org/license.

Section 1. General Terms of Use and Redistributing Project Gutenberg electronic works

1.A. By reading or using any part of this Project Gutenberg electronic work, you indicate that you have read, understand, agree to and accept all the terms of this license and intellectual property (trademark/copyright) agreement. If you do not agree to abide by all the terms of this agreement, you must cease using and return or destroy all copies of Project Gutenberg electronic works in your possession. If you paid a fee for obtaining a copy of or access to a Project Gutenberg electronic work and you do not agree to be bound by the terms of this agreement, you may obtain a refund from the person or entity to whom you paid the fee as set forth in paragraph 1.E.8.

1.B. “Project Gutenberg” is a registered trademark. It may only be used on or associated in any way with an electronic work by people who agree to be bound by the terms of this agreement. There are a few things that you can do with most Project Gutenberg electronic works even without complying with the full terms of this agreement. See paragraph 1.C below. There are a lot of things you can do with Project Gutenberg electronic works if you follow the terms of this agreement and help preserve free future access to Project Gutenberg electronic works. See paragraph 1.E below.

1.C. The Project Gutenberg Literary Archive Foundation (“the Foundation” or PGLAF), owns a compilation copyright in the collection of Project Gutenberg electronic works. Nearly all the individual works in the collection are in the public domain in the United States. If an individual work is unprotected by copyright law in the United States and you are located in the United States, we do not claim a right to prevent you from copying, distributing, performing, displaying or creating derivative works

based on the work as long as all references to Project Gutenberg are removed. Of course, we hope that you will support the Project Gutenberg mission of promoting free access to electronic works by freely sharing Project Gutenberg works in compliance with the terms of this agreement for keeping the Project Gutenberg name associated with the work. You can easily comply with the terms of this agreement by keeping this work in the same format with its attached full Project Gutenberg License when you share it without charge with others.

1.D. The copyright laws of the place where you are located also govern what you can do with this work. Copyright laws in most countries are in a constant state of change. If you are outside the United States, check the laws of your country in addition to the terms of this agreement before downloading, copying, displaying, performing, distributing or creating derivative works based on this work or any other Project Gutenberg work. The Foundation makes no representations concerning the copyright status of any work in any country other than the United States.

1.E. Unless you have removed all references to Project Gutenberg:

1.E.1. The following sentence, with active links to, or other immediate access to, the full Project Gutenberg License must appear prominently whenever any copy of a Project Gutenberg work (any work on which the phrase “Project Gutenberg” appears, or with which the phrase “Project Gutenberg” is associated) is accessed, displayed, performed, viewed, copied or distributed:

This eBook is for the use of anyone anywhere in the United States and most other parts of the world at no cost and with almost no restrictions whatsoever. You may copy it, give it away or re-use it under the terms of the Project Gutenberg™ License included with this eBook or online at www.gutenberg.org. If you are not located in the United States, you will have to check the laws of the country where you are located before using this eBook.

1.E.2. If an individual Project Gutenberg electronic work is derived from texts not protected by U.S. copyright law (does not contain a notice indicating that it is posted with permission of the copyright holder), the work can be copied and distributed to anyone in the United States without paying any fees or charges. If you are redistributing or providing access to a work with the phrase “Project Gutenberg” associated with or appearing on the work, you must comply either with the requirements of paragraphs 1.E.1 through 1.E.7 or obtain permission for the use of the work and the Project Gutenberg trademark as set forth in paragraphs 1.E.8 or 1.E.9.

1.E.3. If an individual Project Gutenberg electronic work is posted with the permission of the copyright holder, your use and distribution must comply with both paragraphs 1.E.1 through 1.E.7 and any additional terms imposed by the copyright holder. Additional terms will be linked to the Project Gutenberg License for all works posted with the permission of the copyright holder found at the beginning of this work.

1.E.4. Do not unlink or detach or remove the full Project Gutenberg License terms from this work, or any files containing a part of this work or any other work associated with Project Gutenberg.

1.E.5. Do not copy, display, perform, distribute or redistribute this electronic work, or any part of this electronic work, without prominently displaying the sentence set forth in paragraph 1.E.1 with active links or immediate access to the full terms of the Project Gutenberg License.

1.E.6. You may convert to and distribute this work in any binary, compressed, marked up, nonproprietary or proprietary form, including any word processing or hypertext form. However, if you provide access to or distribute copies of a Project Gutenberg work in a format other than “Plain Vanilla ASCII” or other format used in the official version posted on the official Project Gutenberg website (www.gutenberg.org), you must, at no additional cost, fee or expense to the user, provide a copy, a means of exporting a copy, or a means of obtaining a copy upon request, of the work in its original “Plain Vanilla ASCII” or other form. Any alternate format must include the full Project Gutenberg License as specified in paragraph 1.E.1.

1.E.7. Do not charge a fee for access to, viewing, displaying, performing, copying or distributing any Project Gutenberg works unless you comply with paragraph 1.E.8 or 1.E.9.

1.E.8. You may charge a reasonable fee for copies of or providing access to or distributing Project Gutenberg electronic works provided that:

- You pay a royalty fee of 20% of the gross profits you derive from the use of Project Gutenberg works calculated using the method you already use to calculate your applicable taxes. The fee is owed to the owner of the Project Gutenberg trademark, but he has agreed to donate royalties under this paragraph to the Project Gutenberg Literary Archive Foundation. Royalty payments must be paid within 60 days following each date on which you prepare (or are legally required to prepare) your periodic tax returns. Royalty payments should be clearly marked as such and sent to the Project Gutenberg Literary Archive Foundation at the address specified in Section 4, "Information about donations to the Project Gutenberg Literary Archive Foundation."
- You provide a full refund of any money paid by a user who notifies you in writing (or by e-mail) within 30 days of receipt that s/he does not agree to the terms of the full Project Gutenberg™ License. You must require such a user to return or destroy all copies of the works possessed in a physical medium and discontinue all use of and all access to other copies of Project Gutenberg™ works.
- You provide, in accordance with paragraph 1.F.3, a full refund of any money paid for a work or a replacement copy, if a defect in the electronic work is discovered and reported to you within 90 days of receipt of the work.
- You comply with all other terms of this agreement for free distribution of Project Gutenberg™ works.

1.E.9. If you wish to charge a fee or distribute a Project Gutenberg™ electronic work or group of works on different terms than are set forth in this agreement, you must obtain permission in writing from the Project Gutenberg Literary Archive Foundation, the manager of the Project

Gutenberg™ trademark. Contact the Foundation as set forth in Section 3 below.

1.F.

1.F.1. Project Gutenberg volunteers and employees expend considerable effort to identify, do copyright research on, transcribe and proofread works not protected by U.S. copyright law in creating the Project Gutenberg™ collection. Despite these efforts, Project Gutenberg™ electronic works, and the medium on which they may be stored, may contain “Defects,” such as, but not limited to, incomplete, inaccurate or corrupt data, transcription errors, a copyright or other intellectual property infringement, a defective or damaged disk or other medium, a computer virus, or computer codes that damage or cannot be read by your equipment.

1.F.2. LIMITED WARRANTY, DISCLAIMER OF DAMAGES - Except for the “Right of Replacement or Refund” described in paragraph 1.F.3, the Project Gutenberg Literary Archive Foundation, the owner of the Project Gutenberg™ trademark, and any other party distributing a Project Gutenberg™ electronic work under this agreement, disclaim all liability to you for damages, costs and expenses, including legal fees. YOU AGREE THAT YOU HAVE NO REMEDIES FOR NEGLIGENCE, STRICT LIABILITY, BREACH OF WARRANTY OR BREACH OF CONTRACT EXCEPT THOSE PROVIDED IN PARAGRAPH 1.F.3. YOU AGREE THAT THE FOUNDATION, THE TRADEMARK OWNER, AND ANY DISTRIBUTOR UNDER THIS AGREEMENT WILL NOT BE LIABLE TO YOU FOR ACTUAL, DIRECT, INDIRECT, CONSEQUENTIAL, PUNITIVE OR INCIDENTAL DAMAGES EVEN IF YOU GIVE NOTICE OF THE POSSIBILITY OF SUCH DAMAGE.

1.F.3. LIMITED RIGHT OF REPLACEMENT OR REFUND - If you discover a defect in this electronic work within 90 days of receiving it, you can receive a refund of the money (if any) you paid for it by sending a written explanation to the person you received the work from. If you received the work on a physical medium, you must return the medium with your written explanation. The person or entity that provided you with the defective work may elect to provide a replacement copy in lieu of a refund. If you received the work electronically, the person or entity providing it to

you may choose to give you a second opportunity to receive the work electronically in lieu of a refund. If the second copy is also defective, you may demand a refund in writing without further opportunities to fix the problem.

1.F.4. Except for the limited right of replacement or refund set forth in paragraph 1.F.3, this work is provided to you 'AS-IS', WITH NO OTHER WARRANTIES OF ANY KIND, EXPRESS OR IMPLIED, INCLUDING BUT NOT LIMITED TO WARRANTIES OF MERCHANTABILITY OR FITNESS FOR ANY PURPOSE.

1.F.5. Some states do not allow disclaimers of certain implied warranties or the exclusion or limitation of certain types of damages. If any disclaimer or limitation set forth in this agreement violates the law of the state applicable to this agreement, the agreement shall be interpreted to make the maximum disclaimer or limitation permitted by the applicable state law. The invalidity or unenforceability of any provision of this agreement shall not void the remaining provisions.

1.F.6. INDEMNITY - You agree to indemnify and hold the Foundation, the trademark owner, any agent or employee of the Foundation, anyone providing copies of Project Gutenberg™ electronic works in accordance with this agreement, and any volunteers associated with the production, promotion and distribution of Project Gutenberg™ electronic works, harmless from all liability, costs and expenses, including legal fees, that arise directly or indirectly from any of the following which you do or cause to occur: (a) distribution of this or any Project Gutenberg work, (b) alteration, modification, or additions or deletions to any Project Gutenberg work, and (c) any Defect you cause.

Section 2. Information about the Mission of Project Gutenberg

Project Gutenberg is synonymous with the free distribution of electronic works in formats readable by the widest variety of computers including obsolete, old, middle-aged and new computers. It exists because of the

efforts of hundreds of volunteers and donations from people in all walks of life.

Volunteers and financial support to provide volunteers with the assistance they need are critical to reaching Project Gutenberg's goals and ensuring that the Project Gutenberg collection will remain freely available for generations to come. In 2001, the Project Gutenberg Literary Archive Foundation was created to provide a secure and permanent future for Project Gutenberg and future generations. To learn more about the Project Gutenberg Literary Archive Foundation and how your efforts and donations can help, see Sections 3 and 4 and the Foundation information page at www.gutenberg.org.

Section 3. Information about the Project Gutenberg Literary Archive Foundation

The Project Gutenberg Literary Archive Foundation is a non-profit 501(c)(3) educational corporation organized under the laws of the state of Mississippi and granted tax exempt status by the Internal Revenue Service. The Foundation's EIN or federal tax identification number is 64-6221541. Contributions to the Project Gutenberg Literary Archive Foundation are tax deductible to the full extent permitted by U.S. federal laws and your state's laws.

The Foundation's business office is located at 41 Watchung Plaza #516, Montclair NJ 07042, USA, +1 (862) 621-9288. Email contact links and up to date contact information can be found at the Foundation's website and official page at www.gutenberg.org/contact

Section 4. Information about Donations to the Project Gutenberg Literary Archive Foundation

Project Gutenberg™ depends upon and cannot survive without widespread public support and donations to carry out its mission of increasing the number of public domain and licensed works that can be freely distributed in machine-readable form accessible by the widest array of equipment

including outdated equipment. Many small donations (\$1 to \$5,000) are particularly important to maintaining tax exempt status with the IRS.

The Foundation is committed to complying with the laws regulating charities and charitable donations in all 50 states of the United States. Compliance requirements are not uniform and it takes a considerable effort, much paperwork and many fees to meet and keep up with these requirements. We do not solicit donations in locations where we have not received written confirmation of compliance. To SEND DONATIONS or determine the status of compliance for any particular state visit www.gutenberg.org/donate.

While we cannot and do not solicit contributions from states where we have not met the solicitation requirements, we know of no prohibition against accepting unsolicited donations from donors in such states who approach us with offers to donate.

International donations are gratefully accepted, but we cannot make any statements concerning tax treatment of donations received from outside the United States. U.S. laws alone swamp our small staff.

Please check the Project Gutenberg web pages for current donation methods and addresses. Donations are accepted in a number of other ways including checks, online payments and credit card donations. To donate, please visit: www.gutenberg.org/donate.

Section 5. General Information About Project Gutenberg electronic works

Professor Michael S. Hart was the originator of the Project Gutenberg concept of a library of electronic works that could be freely shared with anyone. For forty years, he produced and distributed Project Gutenberg eBooks with only a loose network of volunteer support.

Project Gutenberg eBooks are often created from several printed editions, all of which are confirmed as not protected by copyright in the U.S. unless a

copyright notice is included. Thus, we do not necessarily keep eBooks in compliance with any particular paper edition.

Most people start at our website which has the main PG search facility:
www.gutenberg.org.

This website includes information about Project Gutenberg, including how to make donations to the Project Gutenberg Literary Archive Foundation, how to help produce our new eBooks, and how to subscribe to our email newsletter to hear about new eBooks.