

PHILLIP REIS
INVENTOR OF
THE TELEPHONE

BY

SILVANUS P. THOMPSON B.A., D.Sc.



PHILLIP REIS
INVENTOR OF
THE TELEPHONE

BY

SILVANUS P. THOMPSON B.A., D.Sc.

**The Project Gutenberg eBook of Philipp Reis: Inventor of the
Telephone**

This eBook is for the use of anyone anywhere in the United States and most other parts of the world at no cost and with almost no restrictions whatsoever. You may copy it, give it away or re-use it under the terms of the Project Gutenberg License included with this eBook or online at www.gutenberg.org. If you are not located in the United States, you will have to check the laws of the country where you are located before using this eBook.

Title: Philipp Reis: Inventor of the Telephone

Author: Silvanus P. Thompson

Release date: February 11, 2018 [eBook #56542]

Language: English

Other information and formats:

www.gutenberg.org/ebooks/56542

Credits: Produced by Chris Curnow, Chris Jordan and the Online

Distributed Proofreading Team at <http://www.pgdp.net>

(This

file was produced from images generously made available by The Internet Archive)

*** START OF THE PROJECT GUTENBERG EBOOK PHILIPP
REIS: INVENTOR OF THE TELEPHONE ***

PREFACE.
PHILIPP REIS.
CHAPTER I.
CHAPTER II.
CHAPTER III.
CHAPTER IV.
CHAPTER V.
APPENDIX I.
APPENDIX II.
APPENDIX III.
APPENDIX IV.
ADDITIONAL PREFERENCES
CONCERNING REIS'S TELEPHONE.
JUST PUBLISHED.
NOW COMPLETE.
FOOTNOTES:



**MEDALLION AND AUTOGRAPH FROM
MONUMENT TO PHILIPP REIS AT
FRIEDRICHSDORF.**

PHILIPP REIS:

INVENTOR OF
THE TELEPHONE.

A BIOGRAPHICAL SKETCH,
WITH DOCUMENTARY TESTIMONY, TRANSLATIONS OF
THE ORIGINAL PAPERS OF THE INVENTOR AND
CONTEMPORARY PUBLICATIONS.

BY

SILVANUS P. THOMPSON, B.A., D.Sc., PROFESSOR OF
EXPERIMENTAL PHYSICS IN UNIVERSITY COLLEGE, BRISTOL.

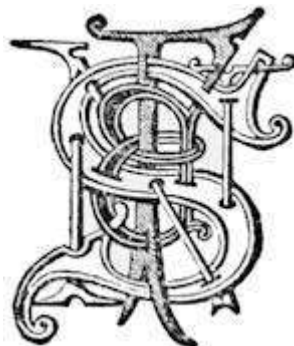

LONDON: E. & F. N. SPON, 16, CHARING CROSS.
NEW YORK: 35, MURRAY STREET.
1883.

PREFACE.

The title of this little work sufficiently indicates its nature and scope. The labour of preparing it has not been slight, and has involved the expenditure of much time in prosecuting inquiries both in this country and in Germany amongst the surviving contemporaries of Philipp Reis. To set forth the history of this long-neglected inventor and of his instrument, and to establish upon its own merits, without special pleading, and without partiality, the nature of that much-misunderstood and much-abused invention, has been the aim of the writer. The thought that he might thus be of service in rendering justice to the memory of the departed worthy has inspired him to his task. He has nothing to gain by making Reis's invention appear either better or worse than it really was. He has therefore preferred to let the contemporary documents and the testimony of eye-witnesses speak for themselves, and has added that which seemed to him desirable in the way of argument in the form of four appendices.

The author's acknowledgments are due in an especial manner to Mr. Albert Stetson, A.M., of Cohasset, Massachusetts, who has given him much valuable assistance in the collection of information both in Germany and in this country, and who has also assisted in the translation of some of the contemporary documents to be found in the work. To the friends, acquaintances, and pupils of Philipp Reis, and especially to the surviving members of the family at Friedrichsdorf, who have most kindly furnished many details of information, the author would express his most cordial thanks. The testimony now adduced as to the aim of Philipp Reis's invention, and the measure of success which he himself attained, is such, in the author's opinion, and in the opinion, he trusts, of all right-thinking persons, to place beyond cavil the rightfulness of the claim which Reis himself put forward of being the inventor of the Telephone. Full and sufficient as that testimony is, much more remains as yet unpublished. The author has, for example, been permitted to examine a mass of evidence collected by the Dolbear Telephone Company, which entirely corroborates that which is here presented. It is, however, for

certain reasons beyond the author's control, deemed well at the present moment to withhold this testimony for a little while from publication. The appearance of this volume at the present time needs no apology from the author. He is conscious that all he can do will add little or nothing to the lustre with which the name of Philipp Reis will be handed down to posterity. When the Jubilee of Philipp Reis comes to be celebrated in 1884 (January 7th), the world will find out its indebtedness to the great man whose thoughts survive him.

PHILIPP REIS.

CHAPTER I.

BIOGRAPHY OF THE INVENTOR.

[Compiled chiefly from papers left by the deceased, and from the biographical notice of the late Professor Schenk.]

Philipp Reis, or, as his full name appears from his autobiographical sketch to have been, Johann Philipp Reis, was born on the 7th of January, 1834, at Gelnhausen, in the principality of Cassel. His father, who belonged to the Evangelical Church, was a master baker, but also pursued farming to some extent, as the circumstances of small provincial towns generally require. As his mother had died young, his paternal grandmother undertook the bringing up of the boy. "While my father," writes Herr Reis, "strove constantly to cultivate my mental powers by instruction concerning the things which surrounded me (by discussing that which was actually observed), my grandmother turned her activity to training my disposition and to the development of the religious sentiments to which she was eminently fitted by the experiences of a long life, by being well-read, and especially by her gift of narration."

On attaining his sixth year the boy was sent to the common school of his native town. His teachers soon recognised that he possessed no ordinary endowments, and sought to induce his father to entrust him later to a higher institution of learning. His father agreed to this; and the plan was to have been carried out after the boy had passed the middle-class of the common school. How the father contemplated the carrying out of the plan is not known; he died ere the son had yet completed his tenth year.

As a considerable number of children from Frankfort-on-the-Main and its neighbourhood, attended that time Garnier's Institute at Friedrichsdorf, near Homburg, the idea occurred to his guardian and his grandmother to entrust the boy to this school. He entered there when in his eleventh year. "The foreign languages, English and French, taught in the Institute, attracted me specially. The library of the Institute, rich and well chosen for its size, gave my mind excellent nourishment." At the

end of his fourteenth year he had passed through the school, organised as it then was, and he now went to Hassel's Institute at Frankfort-on-the-Main. His delight in the study of language induced him to learn Latin and Italian. And here, also, the taste for the study of natural sciences and mathematics appears to have been awakened in him. The lively zeal with which he applied himself to both these disciplines induced his teachers to advise his guardian that he should allow the boy to attend the Polytechnic School at Karlsruhe, on finishing his course at the Institute. "All the endeavours of my well-wishing teachers shattered themselves, however, against the will of one of my guardians, who was also my uncle. He wished that I should follow mercantile pursuits.... I wrote him at that time that I should, indeed, be obedient and learn the pursuit prescribed for me, but that I should in any case continue my studies later."

On the 1st of March, 1850, Philipp Reis entered the colour establishment of Mr. J. F. Beyerbach, of Frankfort, as an apprentice. By diligence and punctuality he soon won the esteem of his principal. All his leisure time he bestowed upon his further education. He took private lessons in mathematics and physics, and attended the lectures of Professor R. Böttger, on Mechanics, at the Trade School. And so the end of his apprenticeship arrived. At the conclusion of it he entered the Institute of Dr. Poppe, in Frankfort. "Several of my comrades in this establishment, young people of sixteen to twenty years old, found it, as I did, a defect that no natural history, history, or geography, was taught. We determined, therefore, to instruct one another in these subjects. I undertook geography, and formed from this first occasion of acting as teacher the conviction that this was my vocation. Dr. Poppe confirmed me in this view and aided me by word and deed."

In the year 1851, whilst resident in Frankfort, Reis had become a member of the Physical Society of that city. This Society, which still flourishes, then held, and still continues to hold, its meetings in the Senckenburg Museum. Lectures in Chemistry and Physics are delivered by resident professors in regular courses every week throughout the winter, under the auspices of this Society; and every Saturday evening is devoted to the exposition of recent discoveries or inventions in the world of physical science, astronomy, etc. The most active members of this Society during the time of Reis's connection with it were the late

Professor Böttger, Professor Abbe (now of Jena), and Dr. Oppel, all of whom contributed many valuable original memoirs to the *Jahresberichte*, or Annual Reports, published by the Society. Amongst its corresponding and honorary members it counted the names of all the best scientific men of Germany, and also the names of Professor Faraday, Professor Sturgeon, and Sir Charles Wheatstone. Doubtless the discussion of scientific questions at this Society greatly influenced young Reis. He remained for three years a member, but dropped his connexion for a time on leaving Frankfort. He subsequently rejoined the Society in the session of 1860-61, remaining a member until 1867, when he finally resigned.

In the winter of 1854-5 we find him most zealously busied with preparations for carrying out his decision to become a teacher. In 1855, he went through his year of military service at Cassel. Returning to Frankfort, he worked away with his customary and marvellous energy, attended lectures on mathematics and the sciences, worked in the laboratory, and studied books on Pedagogy. "Thus prepared, I set my mind on going to Heidelberg in order to put the finishing touch to my education as teacher. I wanted to settle down in Frankfort in this capacity, and undertake instruction in mathematics and science in the various schools. Then in the spring of 1858, I visited my former master, Hofrath Garnier, in whom I had ever found a fatherly friend. When I disclosed to him my intentions and prospects, he offered me a post in his Institute. Partly gratitude and attachment, and partly the ardent desire to make myself right quickly useful, induced me to accept the proffered post."

In the autumn of the year 1858 he returned to Friedrichsdorf, and in September 1859 he married and founded his peaceful home.

Until Easter, 1859, he had but few lessons to give; that he utilised every moment of his spare time most conscientiously in earnest activity and sound progress is nothing more than was to be expected from what has been said above.

It was during this time that Reis undertook the first experimental researches of an original nature. Working almost alone, and without any scientific guide, he was led into lines of thought not previously trodden. He had conceived an idea that electrical forces could be propagated across space without any material conductor in the same way as light is propagated. He made many experiments on the subject, the precise

nature of which can never now be known, but in which a large concave mirror was employed in conjunction with an electroscope and a source of electrification. The results which he obtained he embodied in a paper, of which no trace now remains, bearing as its title 'On the Radiation of Electricity.' This paper he sent in 1859 to Professor Poggendorff for insertion in Poggendorff's well-known 'Annalen der Physik.' Greatly to his disappointment the memoir was not accepted by Professor Poggendorff. Its rejection was a great blow to the sensitive and highly strung temperament of the young teacher; and as will be seen was not without its consequences.

The other piece of original work undertaken at this time was the research which resulted in his great invention—the Telephone. From the brief biographical notes written by the lamented inventor in 1868 we extract the following:—

“Incited thereto by my lessons in Physics in the year 1860, I attacked a work begun much earlier concerning the organs of hearing, and soon had the joy to see my pains rewarded with success, since I succeeded in inventing an apparatus, by which it is possible to make clear and evident the functions of the organs of hearing, but with which also one can reproduce tones of all kinds at any desired distance by means of the galvanic current. I named the instrument 'Telephon.' The recognition of me on so many sides, which has taken place in consequence of this invention, especially at the Naturalists' Association (Versammlung Deutscher Naturforscher) at Giessen, has continually helped to quicken my ardour for study, that I may show myself worthy of the luck that has befallen me.”

His earliest telephones were made by his own hands, in a little workshop behind his house, whence he laid on wires into an upper room. He also carried a wire from the physical cabinet of Garnier's Institute across the playground into one of the class-rooms for experimental telephonic communication; and a firmly established tradition of the school is still preserved, that the boys were afraid of making a noise in that class-room for fear Herr Reis should hear them in his place amongst his favourite instruments.

In 1862 Reis sent once again to Professor Poggendorff a memoir, this time on the Telephone. This, in spite of the advocacy of Professor

Böttger and of Professor Müller of Freiburg, both of whom wrote, was declined by Professor Poggendorff, who treated the transmission of speech by electricity as a myth. Reis, who was convinced that the rejection was because he was “only a poor schoolmaster,” was more deeply pained than ever.

Of the various public exhibitions of the Telephone given by Reis in the years 1861 to 1864, much will be found in the latter part of this book in which the contemporary notices are reprinted. The first public lecture was in 1861, before the Physical Society of Frankfort (see p. 50), the last the above-mentioned occasion at Giessen (see p. 93) in 1864. By this time Reis’s invention was becoming widely known. In addition to his own lectures on the subject, the Telephone had been the subject of lectures in various parts of Germany. It was lectured upon by Professor Buff in Giessen twice, by Professor Böttger both in Frankfort and in Stettin; by Professor H. Pick, by Professor Osann of Würzburg, by Professor Paul Reis of Mainz, and by others. In 1863 Reis’s Telephone was shown by Dr. Otto Volger, Founder and President of the Free German Institute (Freies Deutsches Hochstift), to the Emperor of Austria and to King Max of Bavaria, then on a visit to Frankfort.

Telephones were being sent to various parts of the world. They were to be found in the Physical Laboratories of Munich, Erlangen, Wiesbaden, Vienna, and Cologne. They were sent to distant parts of the world, to London,^[1] to Dublin, to Tiflis in the Caucasus. In Manchester, before the Literary and Philosophical Society, Reis’s Telephone was shown in 1865 by Professor Clifton, who, however, from not having Reis’s own original memoirs on the subject before him, utterly mistook—if the Journal of Proceedings be not in error—the nature of the instrument, and not knowing the theory of vibration of the tympanum so beautifully demonstrated by Reis, imagined the instrument to be a mere harmonic telegraph for transmitting code signals in fixed musical tones! Telephones, too, were becoming an article of commerce and, good and bad,^[2] were being bought for the purpose of placing them in collections of scientific apparatus. The invention was, however, too soon for the world. To Reis’s great disappointment, the Physical Society of Frankfort took no further notice of the invention, the lustre of which shone upon them. He resigned his membership in the Society in October 1867. The Free German Institute of Frankfort, to which Reis had next betaken

himself, though electing him to the dignity of honorary membership, left the invention aside as a philosophic toy. The Naturalists' Assembly, including all the leading scientific men of Germany, had indeed welcomed him at Giessen; but too late. The sensitive temperament had met with too many rebuffs, and the fatal disease with which he was already stricken told upon his energies. In particular the rejection of his earlier researches had preyed upon his disposition. It is narrated by eye-witnesses still living, how, after his successful lecture on the Telephone at Giessen, Reis was asked by Professor Poggendorff, who was present, to write an account of his instrument for insertion in the 'Annalen,' to which request Reis's reply was: "*Ich danke Ihnen recht sehr, Herr Professor; es ist zu spät. Jetzt will ich nicht ihn schicken. Mein Apparat wird ohne Beschreibung in den Annalen bekannt werden.*"

Hæmorrhage of the lungs and a loss of voice, which eventually became almost total, intervened to incapacitate him for work, and especially from working with the telephone. In 1873 he disposed of all his instruments and tools to Garnier's Institute. To Herr Garnier he made the remark that he had showed the world the way to a great invention, which must now be left to others to develop. At last the end came. The annual Report of Garnier's Institute for the academic year 1873-1874 contains the following brief notice of the decease and labours of Philipp Reis:—

"At first active in divers subjects of instruction, he soon concentrated his whole faculties upon instruction in Natural Science, the subject in which his entire thought and work lay. Witnesses of this are not only all they who learned to know him in Frankfort, in the period when he was preparing for his vocation as teacher, but also his colleagues at the Institute, his numerous pupils, and the members of the Naturalists' Association (Naturforscher Versammlung) at Giessen, who, recognising his keen insight, his perseverance and his rich gifts, encouraged him to further investigations in his newly propounded theories. To the Association at Giessen he brought his Telephone. To the Association at Wiesbaden, in September 1872, he intended to exhibit a new ingeniously constructed gravity-machine, but his state of health made it impossible. This had become such during several years, that he was enabled to discharge the duties of his post only by self-control of a special, and, as is generally admitted, unusual nature; and the practice of his vocation

became more difficult when his voice also failed. In the summer of 1873 he was obliged, during several weeks, to lay aside his teaching. As by this rest and that of the autumn vacation an improvement in his condition occurred, he acquired new hopes of recovery, and resumed his teaching in October with his customary energy. But it was only the last flickering up of the expiring lamp of life. Pulmonary consumption, from which he had long suffered, laid him in December upon the sickbed, from which after long and deep pains, at five o'clock in the afternoon, on the 14th of January, 1874, he was released by death."

The closing words of his autobiographical notes, or "*curriculum vitæ*," as he himself styled them, were the following:—

"As I look back upon my life I can indeed say with the Holy Scriptures that it has been 'labour and sorrow.' But I have also to thank the Lord that He has given me His blessing in my calling and in my family, and has bestowed more good upon me than I have known how to ask of Him. The Lord has helped hitherto; He will help yet further."

In 1877, when the Magneto-Telephones of Graham Bell began to make their way into Europe, the friends of Philipp Reis were not slow to reclaim for their deceased comrade the honours due to him. In December 1877, as the columns of the *Neue Frankfurter Presse* show, a lecture was given upon the history of the Telephone, at the Free German Institute, in Frankfort, by Dr. Volger, its President, the same who in 1863 had shown the Telephone to the Emperor of Austria. On that occasion the Telephone of Reis's own construction, presented by him to the Institute after his exhibition of it in 1862, was shown.

Early in 1878 a subscription was raised by members of the Physical Society of Frankfort for the purpose of erecting a monument to the memory of their former colleague. This monument, bearing a portrait medallion, executed by the sculptor, Carl Rumpf, was duly inaugurated on Sunday, December 8, 1878, when an appropriate address was pronounced by the late Dr. Fleck, of Frankfort. The 'Jahresbericht,' of the Physical Society for 1877-78 (p. 44), contains the following brief record:

—

"The Society has erected to the memory of its former member, the inventor of the Telephone, Philipp Reis (deceased in 1874),

teacher, of Friedrichsdorf (see 'Jahresbericht,' 1860-61, pp. 57-64; and 1861-62, p. 13), in the cemetery of that place, a monument which was inaugurated on the 8th of December, 1878. This monument, an obelisk of red sandstone, bears in addition to the dedication, a well-executed medallion portrait of Philipp Reis, modelled by the sculptor, A. C. Rumpf, and executed galvanoplastically by G. v. Kress."

The inscription on Reis's monument in the Friedrichsdorf Cemetery is:—

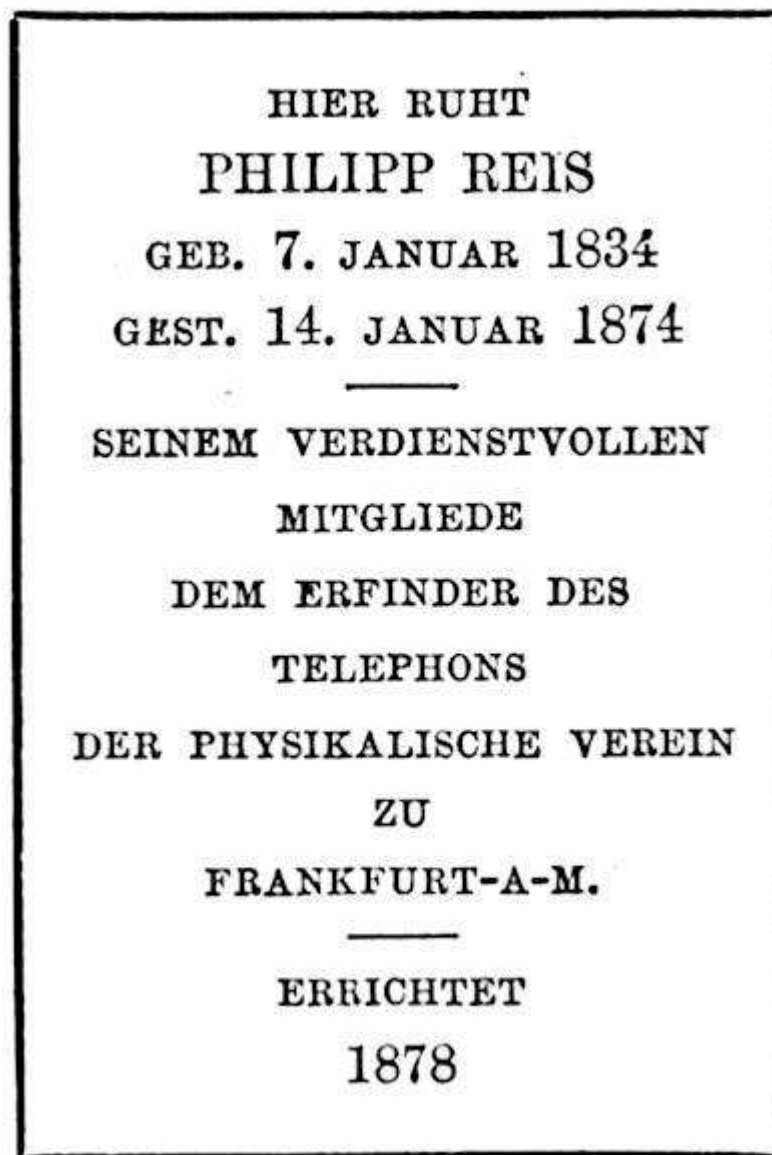

PRINCIPAL DATES IN REIS'S LIFE.

1834	January 7	Philipp Reis born.
1850	March 1	Apprenticed to Beyerbach. Year of Military Service at Cassel. Settled in Friedrichsdorf.
1859	September 14	Married. Invented the Telephone.
1861	October 26	Read Paper "On Telephony by the Galvanic Current" before the Physical Society of Frankfort-on-the-Main.
"	November 16	Read Paper to the Physical Society of Frankfort-on-the-Main, entitled "Explanation of a new Theory concerning the Perception of Chords and of Timbre as a Continuation and Supplement of the Report on the Telephone."
1861	December	Wrote out his Paper "On Telephony," as printed in the 'Jahresbericht.'
1862	May 8	Notice in 'Didaskalia' of Reis's invention.
"	May 11	Lectured and showed the Telephone to the Free German Institute (Freies

Deutsches Hochstift) in Frankfort-on-the-Main.

Article on the Telephone, communicated by Inspector Von Legat to the Austro-German Telegraph Society, and subsequently printed in its 'Zeitschrift' (Journal).

- 1863 July 4 Showed his improved Telephone to the Physical Society of Frankfort-on-the-Main.
- “ September 6 Reis's Telephone shown to the Emperor of Austria and the King of Bavaria, then visiting Frankfort.
- “ Sept. 17-24 Meeting of the “Deutscher Naturforscher” at Stettin; Reis's Telephone shown there by Professor Böttger.
- 1864 February 13 Meeting of the “Oberhessische Gesellschaft für Natur- und Heilkunde” at Giessen; Lecture by Professor Buff, and exhibition by Reis of his Telephone.
- “ September 21 Meeting of the “Deutscher Naturforscher” at Giessen. Reis gave an explanation of the Telephone and the history of its invention, and exhibited it in action before the most

distinguished scientific men of
Germany.

1872 September Meeting of the “Deutscher
Naturforscher” at Wiesbaden; Reis
announced to show his
“Fallmaschine,” but prevented by ill-
health.

1874 January 14 Philipp Reis died.



Fig. 1.
**Monument to Philipp Reis in the Cemetery at
Friedrichsdorf.**

CHAPTER II.

THE INVENTOR'S APPARATUS.

In describing the various forms successively given by the inventor to his apparatus, as he progressed, from the earliest to the latest, it will be convenient to divide them into two groups, viz. the Transmitters and the Receivers.

A.—Reis's Transmitters.

So far as can be learned, Reis constructed transmitters in some ten or twelve different forms. The complete series in this course of evolution does not now exist, but the principal forms still remain and will be described in their historical order. Theoretically, the last was no more perfect than the first, and they all embody the same fundamental idea: they only differ in the mechanical means of carrying out to a greater or less degree of perfection the one common principle of imitating the mechanism of the human ear, and applying that mechanism to affect or control a current of electricity by varying the degree of contact at a loose joint in the circuit.

First Form.—THE MODEL EAR.

Naturally enough the inventor of the Telephone began with crude and primitive^[3] apparatus. The earliest form of telephone-transmitter now extant, was a rough model of the human ear carved in oak wood, and of the natural size, as shown in Figs. [2](#), [3](#), [4](#), & [5](#).

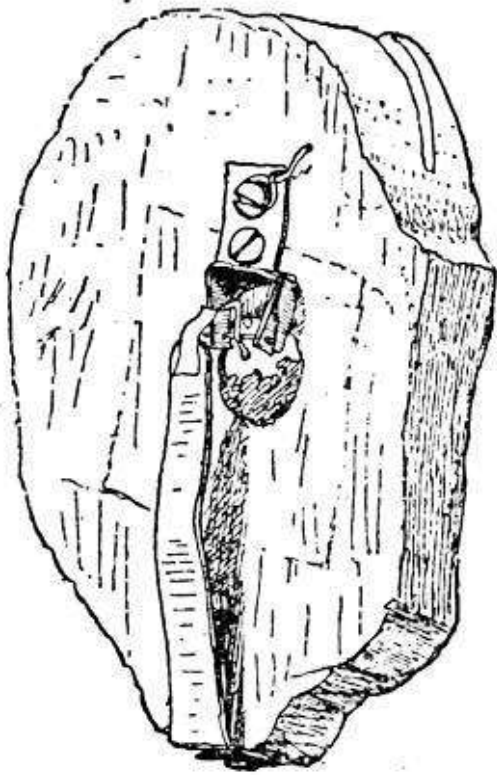

Fig. 2.

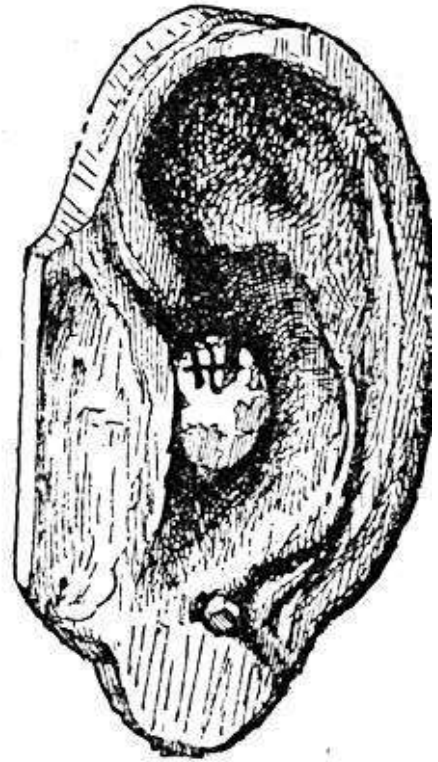

Fig. 3.



Fig. 4.

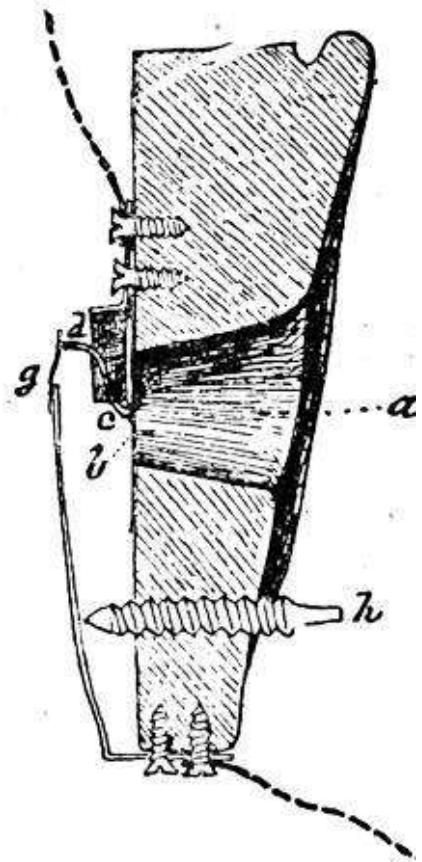

Fig. 5.

The end of the aperture *a* was closed by a thin membrane *b*, in imitation of the human tympanum. Against the centre of the tympanum rested the lower end of a little curved lever *c d*, of platinum wire, which represented the “hammer” bone of the human ear. This curved lever was attached to the membrane by a minute drop of sealing-wax, so that it followed every motion of the same. It was pivoted near its centre by being soldered to a short cross-wire which served as an axis; this axis passing on either side through a hole in a bent strip of tin-plate screwed to the back of the wooden ear. The upper end of the curved lever rested in loose contact against the upper end *g* of a vertical spring, about one inch long, also of tin-plate, bearing at its summit a slender and resilient strip of platinum foil. An adjusting-screw, *h*, served to regulate the degree of contact between the vertical spring and the curved lever. The conducting-wires by which the current of electricity entered and left the apparatus were connected to the screws by which the two strips of tin-plate were fixed to the ear. In order to make sure that the current from the upper support of tin should reach the curved lever, another strip of platinum foil was soldered on the side of the former, and rested lightly against the end of the wire-axis, as shown in

magnified detail in [Fig. 6](#). If now any words or sounds of any kind were uttered in front of the ear the membrane was thereby set into vibrations, as in the human ear. The little curved lever took up these motions precisely as the “hammer”-bone of the human ear does; and, like the “hammer”-bone, transferred them to that with which it was in contact. The result was that the contact of the upper end of the lever was caused to vary. With every rarefaction of the air the membrane moved forward and the upper end of the little lever moved backward and pressed more firmly than before against the spring, making better contact and allowing a stronger current to flow. At every condensation of the air the membrane moved backwards and the upper end of the lever moved forward so as to press less strongly than before against the spring, thereby making a less complete contact than before, and by thus partially interrupting the passage of the current, caused the current to flow less freely. The sound waves which entered the ear would in this fashion throw the electric current, which flowed through the point of variable contact, into undulations in strength. It will be seen that this principle of causing the voice to control the strength of the electric current by causing it to operate upon a loose or imperfect contact, runs throughout the whole of Reis’s telephonic transmitters. In later times such pieces of mechanism for varying the strength of an electric current have been termed current-regulators.^[4] It would not be inappropriate to describe the mechanism which Reis thus invented as a combination of a tympanum with an electric current-regulator, the essential principle of the electric current-regulator being the employment of a loose or imperfect contact between two parts of the conducting system, so arranged that the vibrations of the tympanum would alter the degree of contact and thereby interrupt in a corresponding degree the passage of the current.

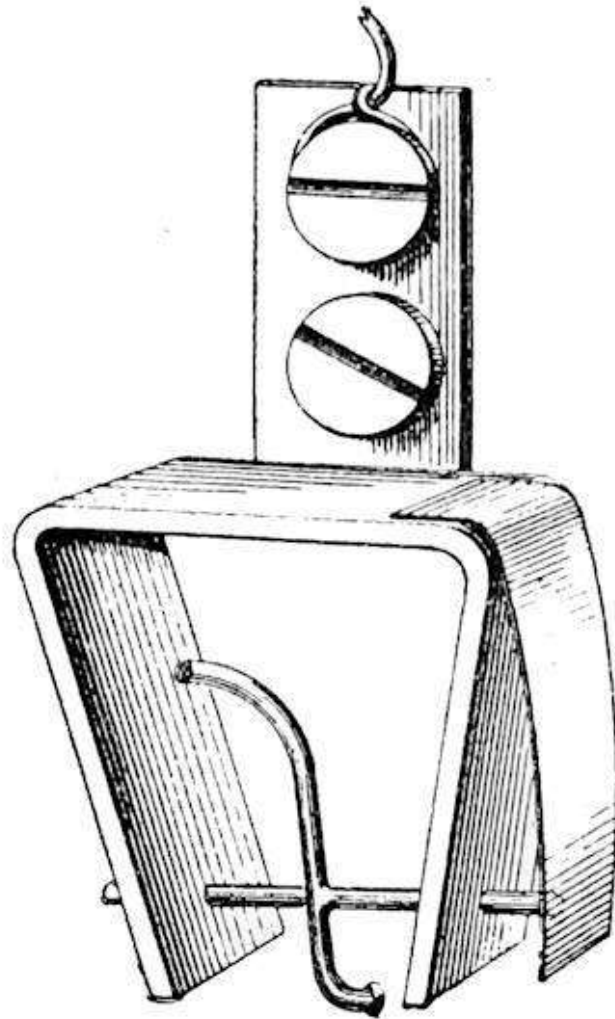

Fig. 6.

Mr. Horkheimer, a former pupil of Reis, informs me that a much larger model of the ear was also constructed by Reis. No trace of this is, however, known.

Second Form.—TIN TUBE.

The second form, a tube constructed by Reis himself, of tin, is still to be seen in the Physical cabinet of Garnier's Institute, at Friedrichsdorf, and is shown in [Fig. 7](#). It consists of an auditory tube *a*, with an embouchure representing the pinna or flap of the ear. This second apparatus shows also a great similarity with the arrangement of the ear, having the pinna or ear-flap, the auditory passage, and the drum-skin (*a, b, c*). Upon the bladder *c* there still remains some sealing-wax, by means of which a little strip of platinum, for the all-essential loose-contact that controlled the current, had formerly been cemented to the apparatus.

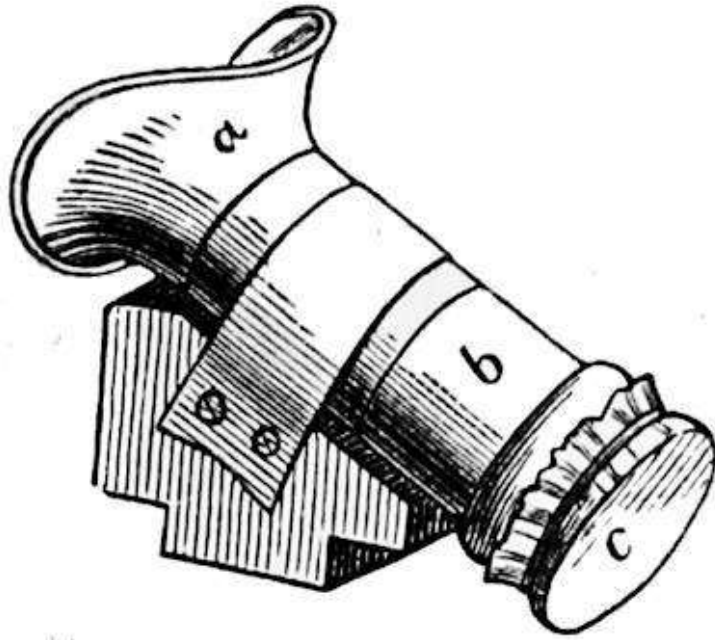

Fig. 7.

Third Form.—THE COLLAR-BOX.

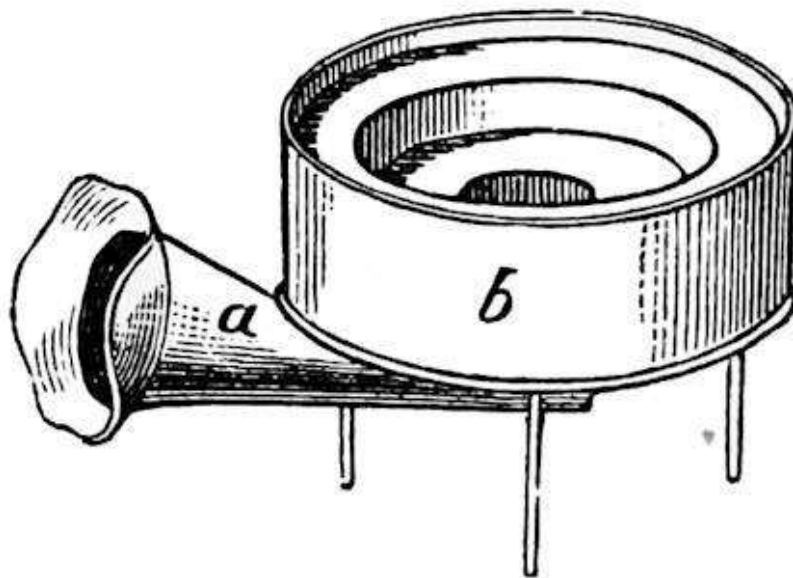

Fig. 8.

The third form, also preserved in the collection in Garnier's Institute, is given in [Fig. 8](#), which, with the preceding, is taken by permission from the pamphlet of the late Professor Schenk, consists of a round tin box, the upper part of which fits upon the lower precisely like the lid of a collar-box. Over this lid *b*, which is 15 centimetres in diameter, was formerly stretched the

vibrating membrane, there being also an inner flange of metal. Into a circular aperture below opened an auditory tube *a*, with an embouchure representing the pinna. The precise arrangements of the contact-parts of this apparatus are not known. Mr. Horkheimer, who aided Reis in his earlier experiments, has no knowledge of this form, which he thinks was made later than June 1862. This is not improbable, as the design with horizontal membrane more nearly approaches that of the tenth form, the “Square-box” pattern.

Fourth Form.—THE BORED-BLOCK.

The instrument described by Reis in his paper “On Telephony,” in the Annual Report of the Physical Society of Frankfort-on-the-Main, for 1860-61 (see p. 50), comes next in order. The inventor’s own description of this telephone ([Fig. 9](#)) is as follows:—

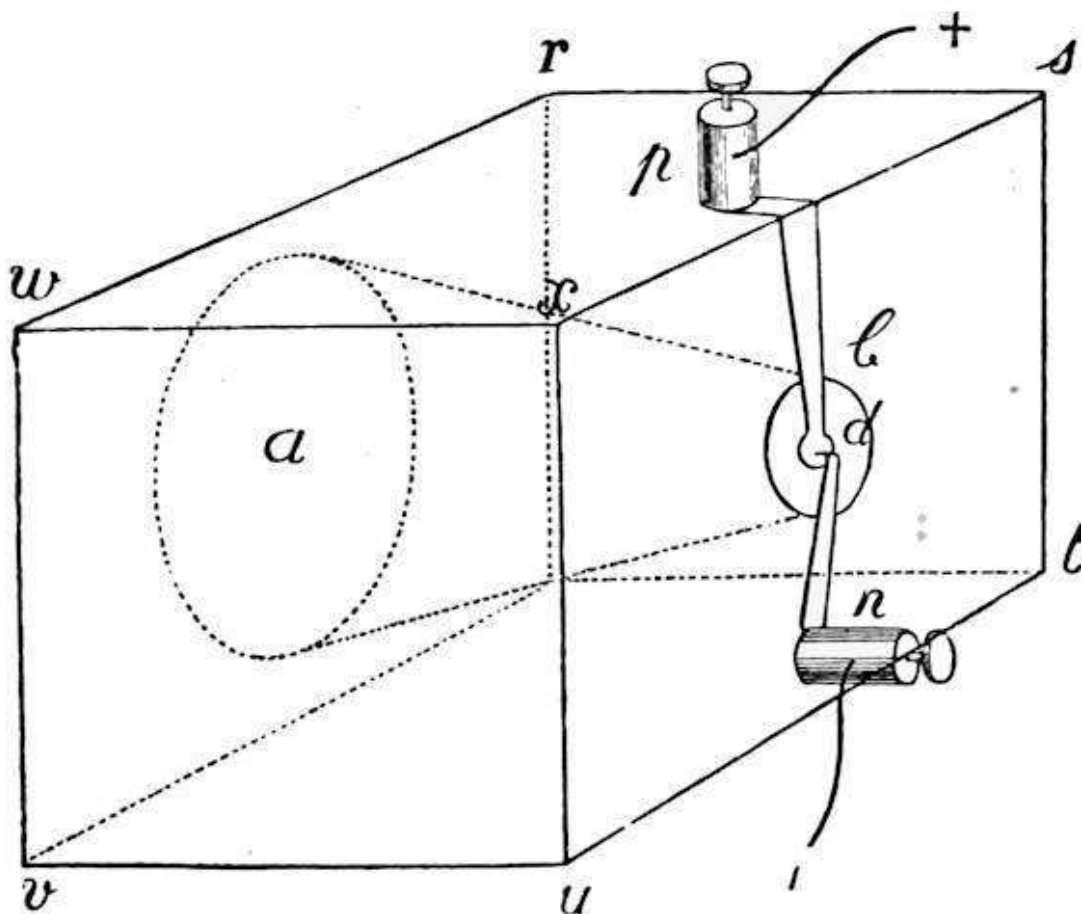

Fig. 9.

“In a cube of wood, *r s t u v w x*, there is a conical hole *a*, closed at one side by the membrane *b* (made of the lesser intestine of the pig), upon the middle of which a little strip of platinum is cemented as a conductor [or

electrode]. This is united with the binding screw *p*. From the binding screw *n* there passes likewise a thin strip of metal over the middle of the membrane, and terminates here in a little platinum wire, which stands at right-angles to the length and breadth of the strip. From the binding-screw *p* a conducting wire leads through the battery to a distant station.” The identical apparatus used by Reis was afterwards given by him to Professor Böttger, who later gave it to Hofrath Dr. Th. Stein, of Frankfort, from whose hands it has recently passed into the possession of the author of this work. It possesses one feature not shown in the original cut, viz. an adjusting screw, *h*, which, so far as the writer can learn, was put there by Reis himself. There appears no reason to doubt this, since there was an adjusting screw in Reis’s very earliest form of transmitter, the wooden ear. A section of the actual instrument is given in [Fig. 10](#).

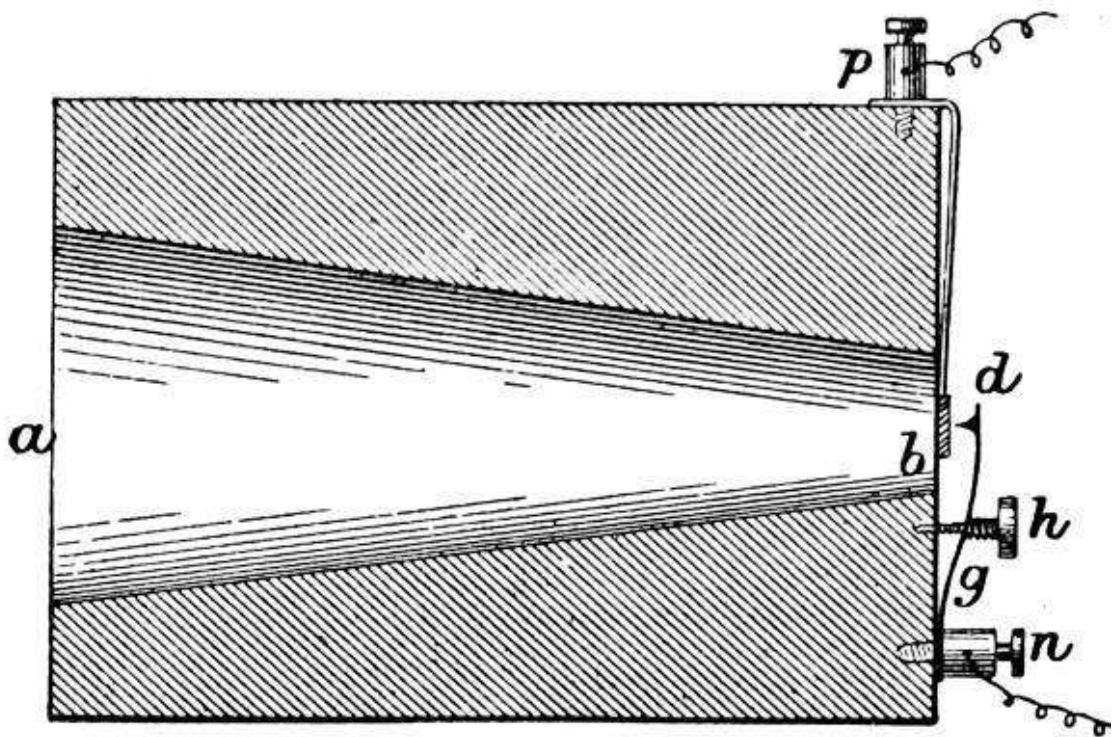

Fig. 10.

Fifth Form.—THE HOLLOW CUBE.

Another form, a mere variety of the preceding, is described as follows by Professor Böttger in his “Polytechnisches Notizblatt” (see p. 61):—

“A little light box, a sort of hollow cube of wood, has a large opening at its front side and a small one at the back of the opposite side. The latter is closed with a very fine membrane (of pig’s smaller intestine) which is

strained stiff. A narrow springy strip of platinum foil, fixed at its outer part to the wood, touches the membrane at its middle; a second platinum strip is fastened by one of its ends to the wood at another spot, and bears at its other end a fine horizontal spike, which touches the other little platinum strip where it lies upon the membrane.”

Sixth Form.—THE WOODEN CONE.

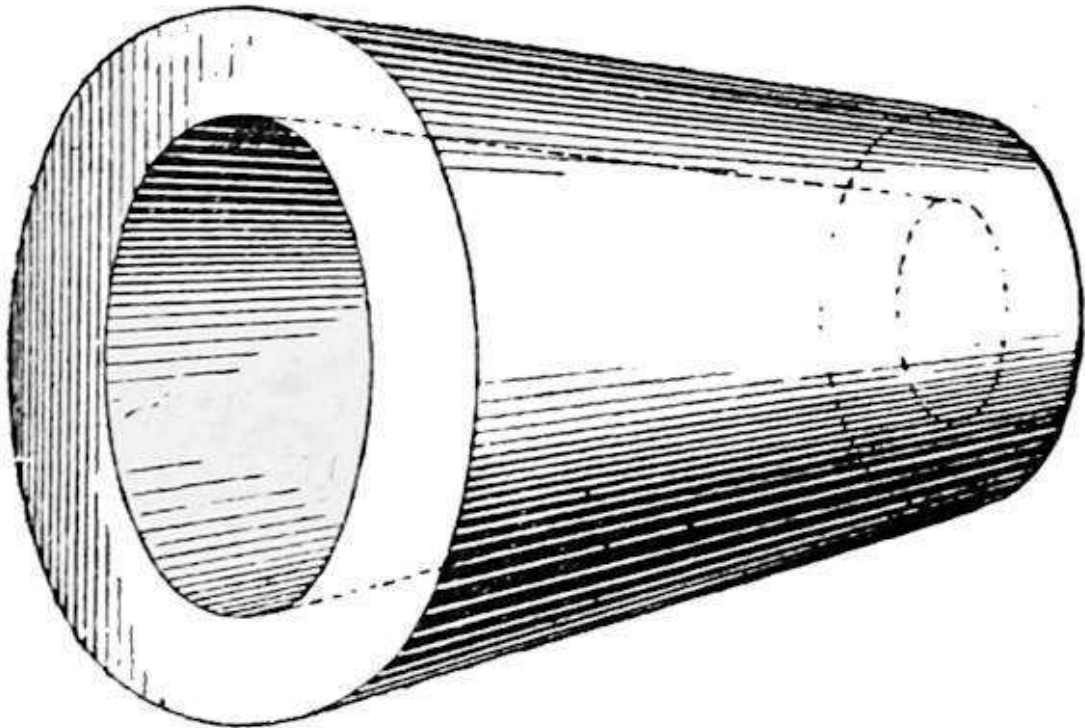

Fig. 11.

Another transmitter, also a mere variety of the Fourth Form, has been described to me by Herr Peter, of Friedrichsdorf, who assisted Reis in his earlier experiments. [Fig. 11](#) is prepared from a rough sketch furnished me by the kindness of Karl Reis. Herr Peter describes the apparatus as having been turned out of a block of wood by Reis upon his own lathe. The conical hole was identical with that of [Fig. 9](#), but the surrounding portions of the wood were cut away, leaving a conical mouth-piece.

Seventh Form.—“HOCHSTIFT” FORM.

The engraving presented below ([Fig. 12](#)) has been engraved with the utmost fidelity by Mr. J. D. Cooper, from a photograph lent to the author by Ernest Horkheimer, Esq., of Manchester, a former pupil of Reis. The original photograph was taken in 1862, having been sent by Reis in June of

that year to Mr. Horkheimer, who had left for England. The photograph was taken by Reis himself with his own camera, the exposure being managed by a slight movement of the foot, actuating a pneumatic contrivance of Reis's own invention, which was originally designed to turn over the pages of a music book at the piano. Reis is here represented as holding in his hand the telephone with which he had a few days preceding (May 11, 1862) achieved such success at his lecture before the Freies Deutsches Hochstift (Free German Institute) in Frankfort (see p. 66). This instrument was constructed by Reis, young Horkheimer assisting him in the construction. Mr. Horkheimer has very obligingly indicated from memory the form of the instrument—but dimly seen in the photograph—in a sketch from which [Fig. 13](#) has been prepared. Mr. Horkheimer adds that the cone was a wooden one; and that the square patch behind at the back was, he thinks, a box to contain an electro-magnet.

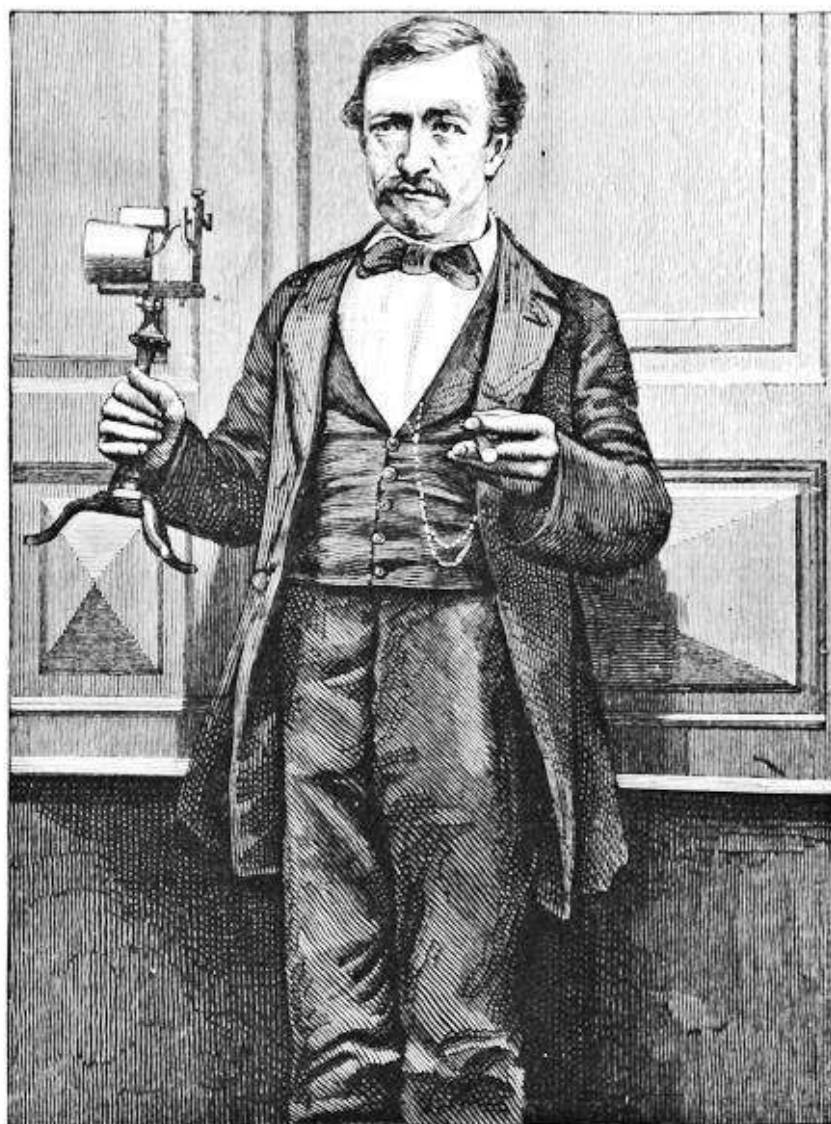

Fig. 12.

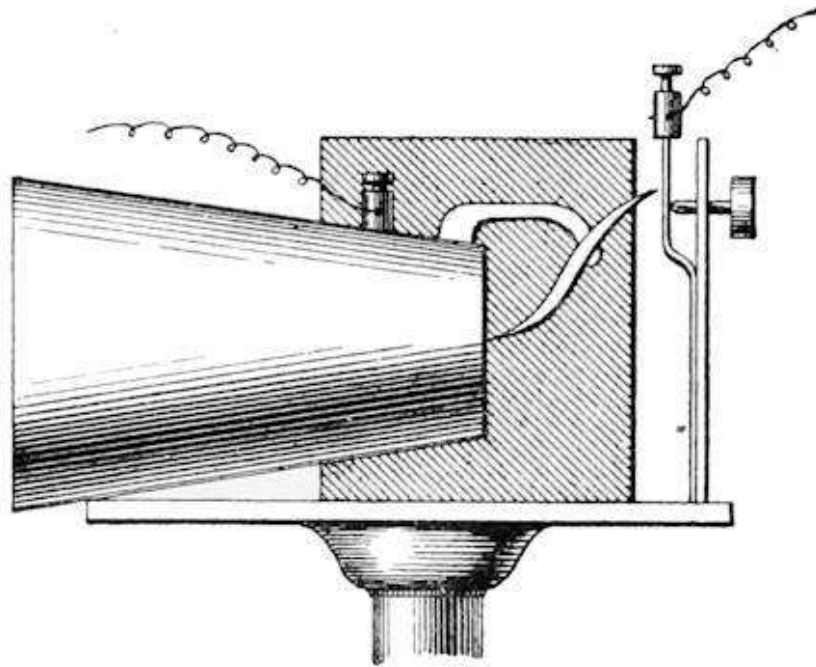

Fig. 13.

Eighth Form.—LEVER FORM.

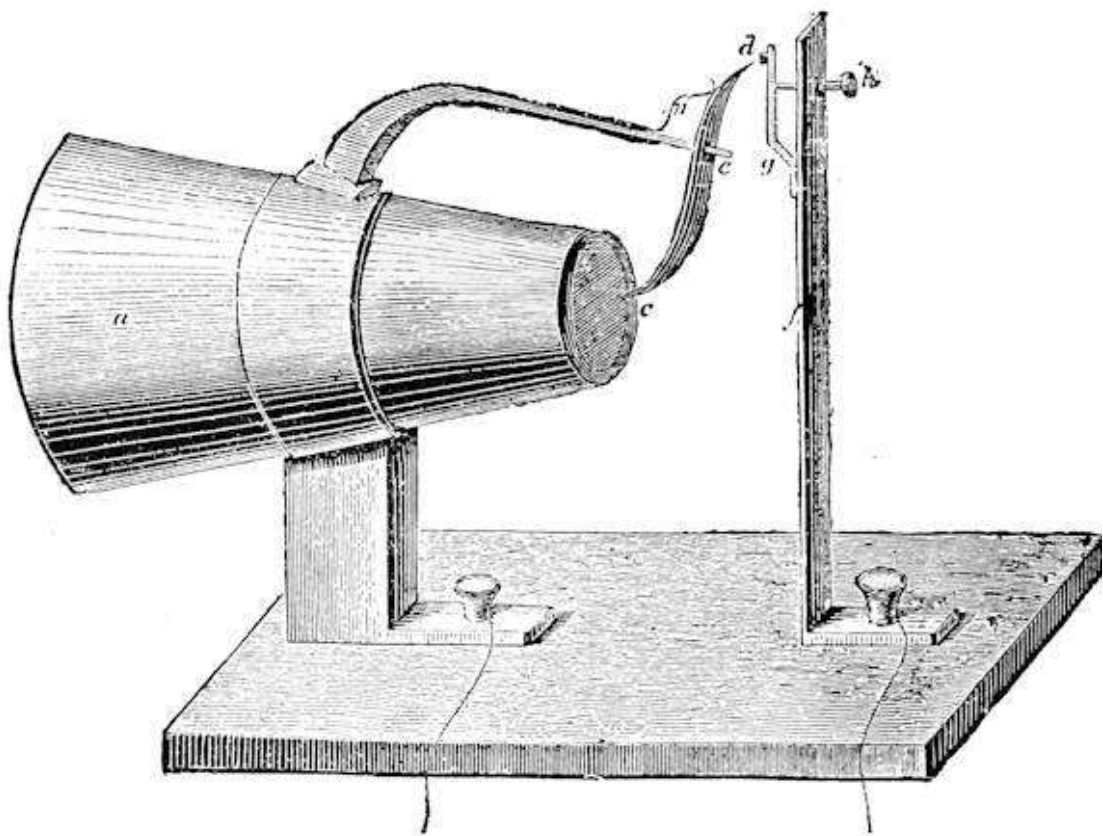

Fig. 14.

The Transmitter described with so much minuteness by Inspector von Legat in his Report on Reis's Telephone in 1862 (see p. 70), differs from the earliest and latest forms, so much so that some have doubted whether this form was really invented by Reis. It is not described anywhere else than in Legat's Report (in the "Zeitschrift" of the Austro-German Telegraph Union, reprinted also in Dingler's Journal), except in Kuhn's Handbook, where, however, the description is taken from Legat. Nevertheless a comparison of this instrument ([Fig. 14](#)) with the original model of the ear, from which Reis started, will show that it embodies no new point. There is, first, a conical tube to receive the sound, closed at its end with a tympanum of membrane. There is next a curved lever, *c d*, the lower end of which rests against the centre of the membrane. Thirdly, there is a vertical spring, *g*, which makes contact lightly against the upper end of the curved lever. Lastly, there is an adjusting screw. It may be further pointed out that in each case the current enters (or leaves, as the case may be) the lever at its middle point. This form of transmitter is so closely allied indeed to the primitive "ear" as to be alike in every feature save the external form of the sound-gathering funnel. The only reasonable doubt is not whether it be, as Legat asserts, Reis's transmitter, but whether it ought not in chronological order to rank second. Legat's paper was not published, however, till 1862, whilst the fourth form was described by Reis in 1861. No trace of any instrument corresponding in form to [Fig. 14](#), save modern reproductions from Legat's drawing, has been found. The instrument held by Reis in his hand in the photograph ([Fig. 12](#)) is so strikingly like the form described by Legat, that it furnishes an additional reason for accepting Legat's statement that this transmitter really is Reis's invention.

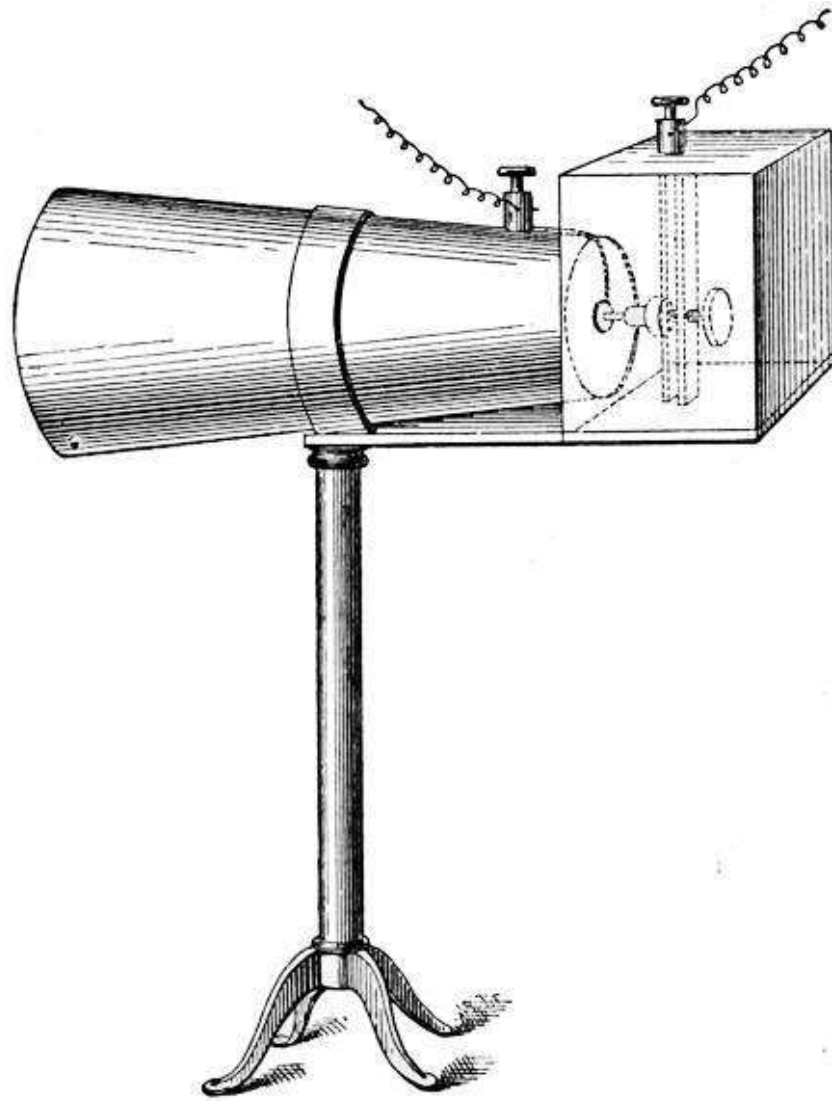

Fig. 15.

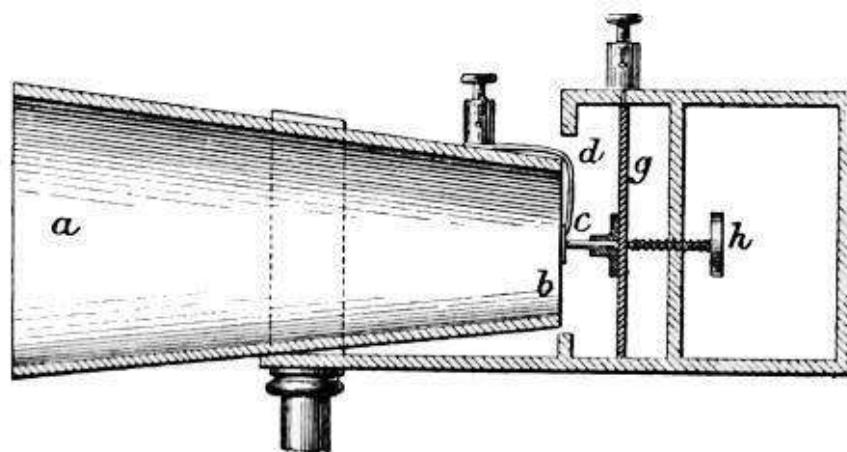

Fig. 16.

Ninth Form.—TRANSITIONAL FORM.

Our knowledge of this form is derived solely from information and sketches supplied by Mr. E. Horkheimer, who assisted Reis in its construction. Figs. [15](#) and [16](#) are engraved after Mr. Horkheimer's sketches. The conical mouthpiece was of wood: the contact pieces of platinum. The point *c* was attached to a springy slip of brass, *g*, fixed across the wooden box; and the adjusting-screw, *h*, served to regulate the degree of initial pressure at the point of contact which controlled the current.

Tenth Form.—THE SQUARE BOX.

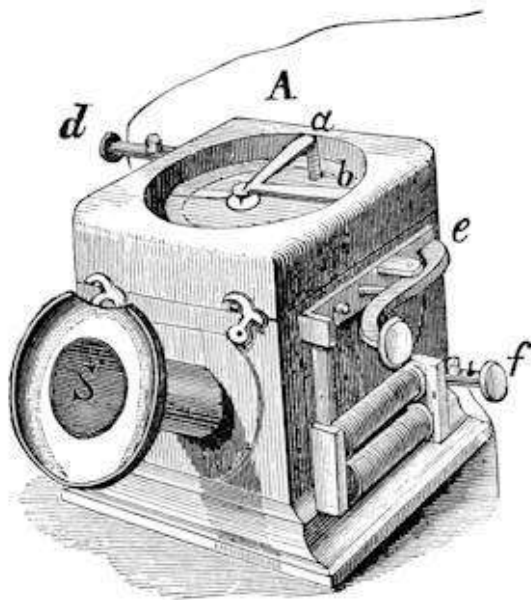

Fig. 17.

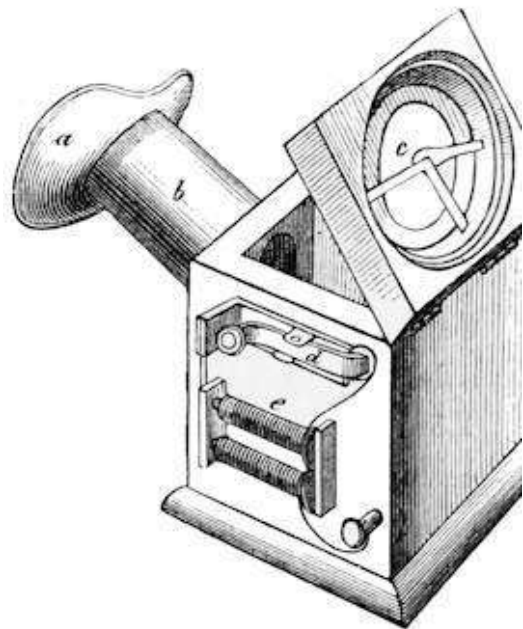

Fig. 18.

The last form of Reis's Transmitter is that which has become best known, being the only one (except [Fig. 9](#)) which found its way into the market. It is here named, for the sake of distinction, as the "Square Box" pattern. It consisted of a square wooden box, having a hinged lid. [Fig. 17](#) is reproduced from Reis's "Prospectus" (see page 85), whilst [Fig. 18](#) is taken from Prof. Schenk's biographical pamphlet.

In this instrument the idea of the human ear is still carried out. The tin funnel, with its flaring embouchure, still represents the auditory tube and pinna. The tympanum, no longer at the very end of the tube, is strained across a circular aperture in the lid. Upon it rests the strip of platinum foil which serves as an electrode, and resting in loose contact with this lies the little angular piece of metal which Reis called the "Hämmerchen." Above all lay a circular glass disk (a cover to keep out the dust), which was

removed when the instrument was used. So sensitive did this form prove itself that it was found unnecessary to speak right into the mouthpiece, and the speaker in practice talked or sang with his mouth at some little distance vertically above the instrument; a method which had the advantage of not so soon relaxing the membrane by the moisture of the breath. The figures show also the auxiliary apparatus attached at the side, consisting of a key for interrupting the circuit (added at first to enable the experimenters to single out the “galvanic tones” from the reproduced tones, and later applied, as Reis explains in his “Prospectus,” on page 87), and an electro-magnet to serve as a “call,” by which the listener at the other end could signal back to the transmitter.

This form of instrument, which has been so frequently described in the Text-books of Physics, was constructed for sale first by Albert of Frankfort, later by Ladd of London, König of Paris, and Hauck of Vienna. Further details concerning it will be found in this book, in Reis’s “Prospectus,” and in other contemporary documents.

Although this form is the one most commonly referred to as “the Reis Telephone,” it is evident from a consideration of the entire group of forms that Reis’s invention was in no way limited to one individual pattern of instrument. For in all these forms there was embodied one all-embracing principle;—that of controlling the electric current by the voice working upon a point of imperfect contact, by the agency of a tympanum, thereby opening or closing the circuit to a greater or less degree, and so regulating the flow of the current.

B.—Reis’s Receivers.

First Form.—THE VIOLIN RECEIVER.

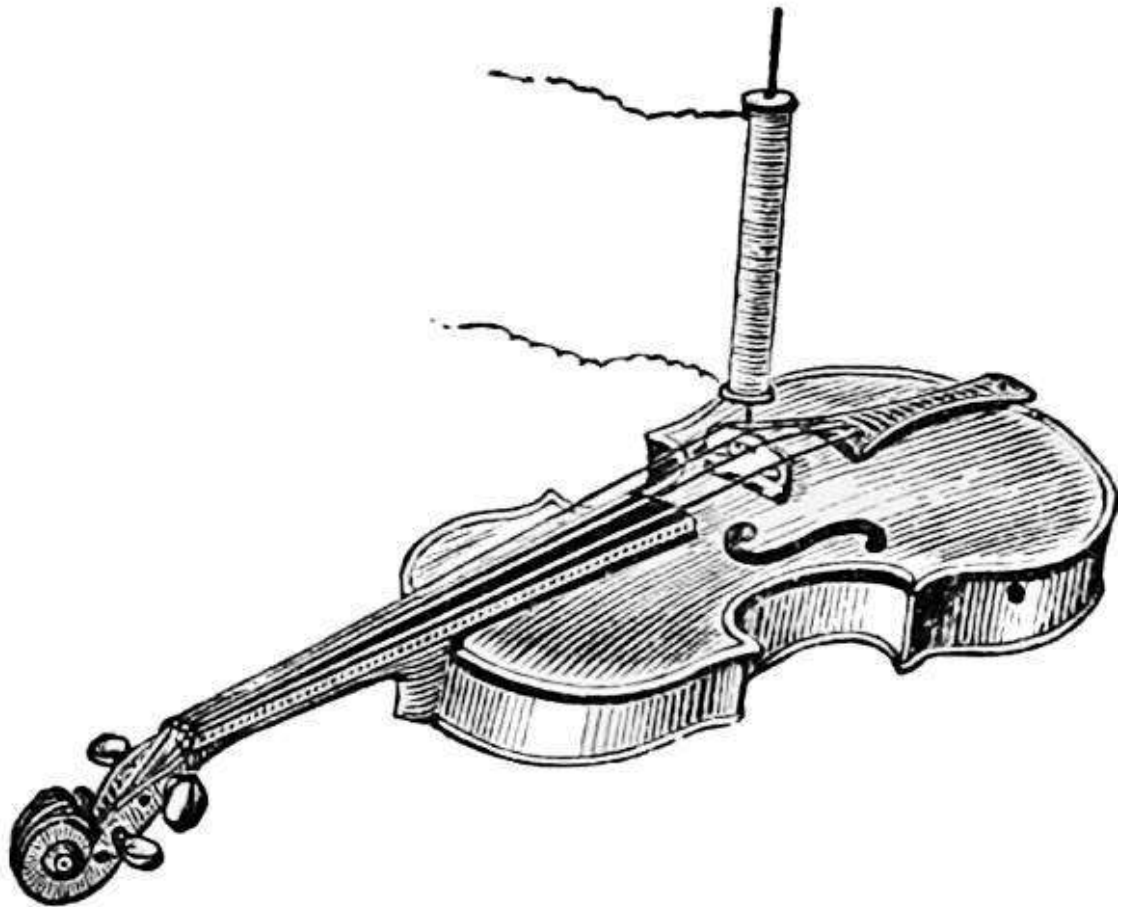

Fig. 19.

The first form of apparatus used by Reis for receiving the currents from the transmitter, and for reproducing audibly that which had been spoken or sung, consisted of a steel knitting-needle, round which was wound a spiral coil of silk-covered copper-wire. This wire, as Reis explains in his lecture "On Telephony," was magnetised in varying degrees by the successive currents, and when thus rapidly magnetised and demagnetised, emitted tones depending upon the frequency, strength, etc., of the currents which flowed round it. It was soon found that the sounds it emitted required to be strengthened by the addition of a sounding-box, or resonant-case. This was in the first instance attained by placing the needle upon the sounding-board of a violin. At the first trial it was stuck loosely into one of the *f*-shaped holes of the violin (see [Fig. 19](#)): subsequently the needle was fixed by its lower end to the bridge of the violin. These details were furnished by Herr Peter, of Friedrichsdorf, music-teacher in Garnier's Institute, to whom the violin belonged, and who gave Reis, expressly for this purpose, a violin of less value than that used by himself in his profession. Reis, who was not himself a musician, and indeed had so little of a musical ear as hardly to know one piece of music from another, kept this violin for the purpose of a

sounding-box. It has now passed into the possession of Garnier's Institute. It was in this form that the instrument was shown by Reis in October 1861 to the Physical Society of Frankfort.

Second Form.—THE CIGAR-BOX RECEIVER.

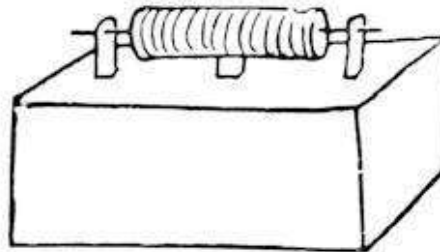

Fig. 20.

Later a shallow rectangular wooden box was substituted for the violin, and the spiral was laid horizontally upon it ([Fig. 20](#)). The date when this modification was made was either at the end of 1861 or the early spring of 1862. A cigar-box was the actual sounding-box, and the needle was supported within the coil, but not touching it, with its ends resting upon two wooden bridges.

Third Form.—THE ELECTRO-MAGNET RECEIVER.

Though the precise history of this form of telephonic receiver is defective, there can be little doubt that it was conceived by Reis amongst his earliest researches. When there were in common use so many electric and telegraphic instruments in which an electro-magnet is employed to move an armature to and fro, it is not surprising that Reis should have thought of availing himself of this method for reproducing the vibrations of speech. Speaking of the two parts of his invention, the Transmitter and the Receiver, Reis himself says:^[5] “The apparatus named the ‘Telephone,’ constructed by me, affords the possibility of evoking sound-vibrations in every manner that may be desired. *Electro-magnetism* affords the possibility of calling into life at any given distance vibrations similar to the vibrations that have been produced, and in this way to give out again in one place the tones that have been produced in another place.” A remark, almost identical with this, is also made by Inspector von Legat (see p. 74) in his Report on Reis's Telephone. It may be here remarked that the form of this receiver is known only from the figure and description given in that Report, and from

the extract therefrom printed in Kuhn's 'Handbook' (see p. 109). Reis seems to have very soon abandoned this form, and to have returned to the needle, surrounded by a coil, in preference to the electro-magnet. The electro-magnet form is, however, of great importance, because its principle is a complete and perfect anticipation of that of the later receivers of Yeates, of Gray, and of Bell, who each, like Reis, employed as receiver an electro-magnet the function of which was to draw an elastically mounted armature backwards and forwards, and so to throw it into vibrations corresponding to those imparted to the transmitting apparatus. [Fig. 21](#) shows the disposition of the electro-magnet, and of its vibratory armature upon a sounding-board. This apparatus was a good deal larger than most of Reis's instruments. The sounding-board was nearly a foot long: the coils of the electro-magnet were six inches long, and over an inch thick. The armature, a rod of iron of elliptical section, was affixed cross-wise at the end of a "light and broad" vertical lever, about seven inches long, which seems to have been made of wood, as in Legat's Report it is also denominated as a "plank" (Balken).

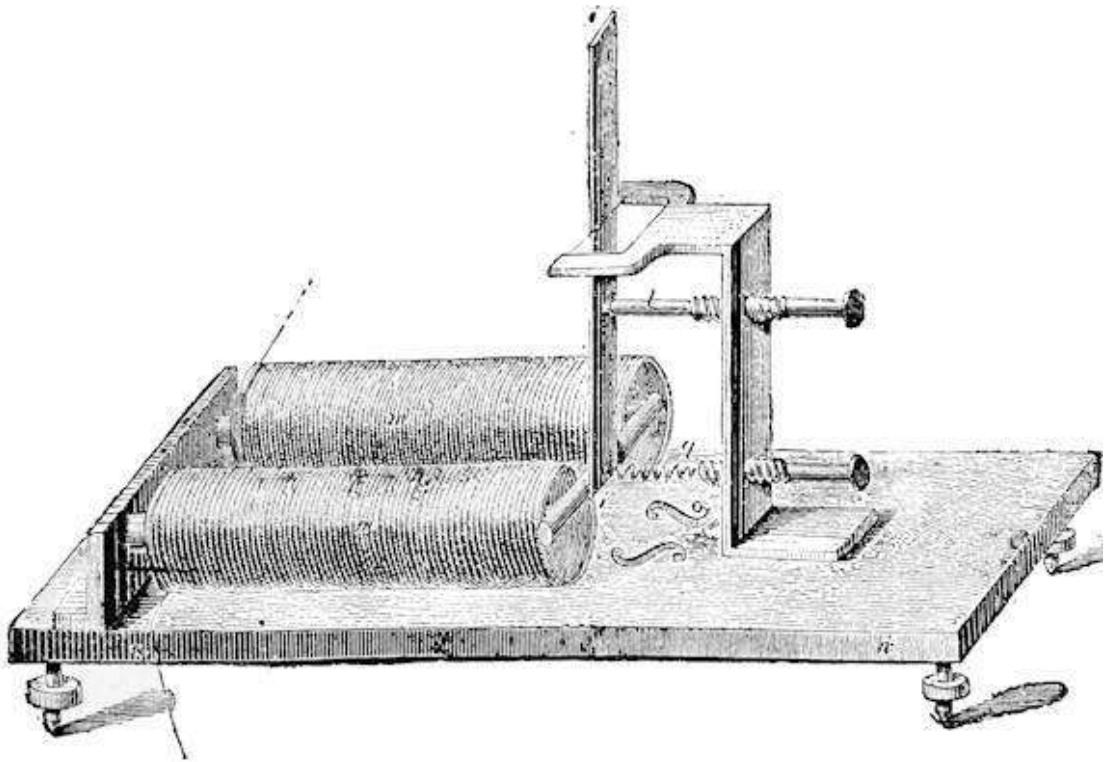

Fig. 21.

Fourth Form.—THE KNITTING-NEEDLE RECEIVER.

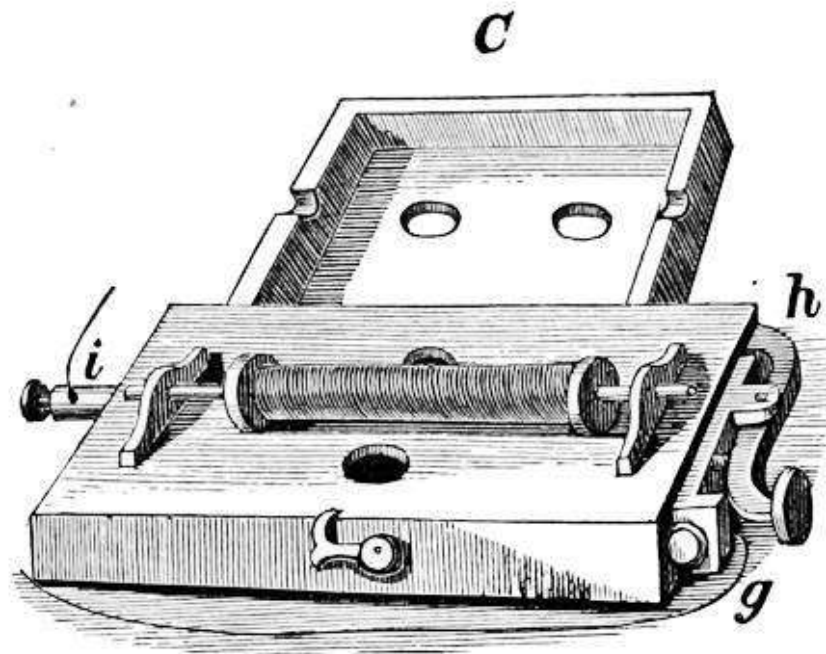

Fig. 22.

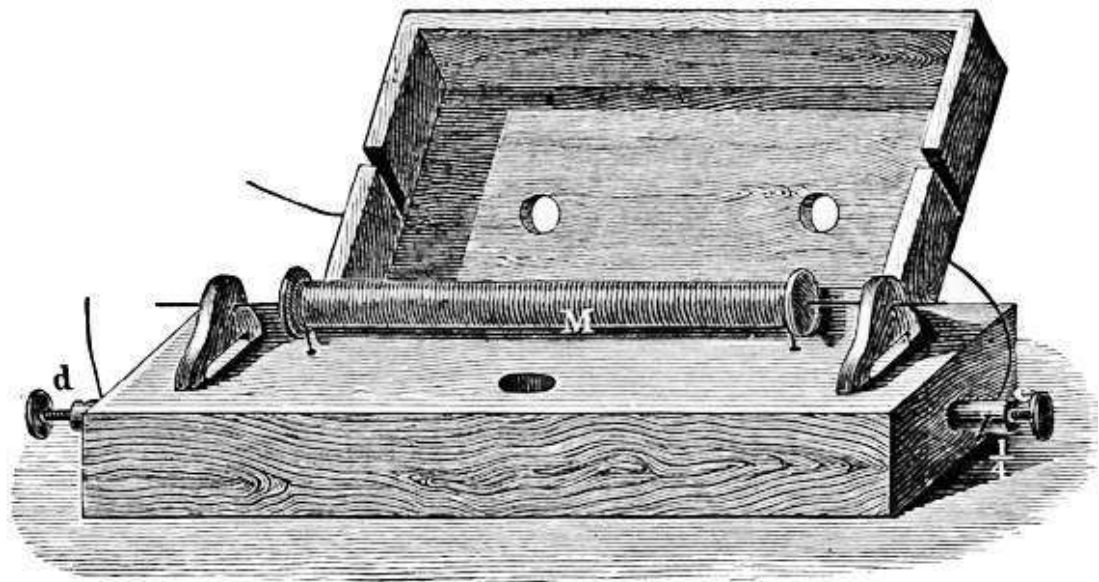

Fig. 23.

The final form adopted by Reis for his Reproducing-apparatus is that commonly known as the Knitting-needle Receiver. It differs only from the first form in that the needle and its surrounding spiral no longer stand upright on a violin, but lie horizontally upon a rectangular sounding-box of thin pine wood. The coil of silk-covered copper wire is wound upon a light wooden bobbin, instead of being twisted round the needle itself. Two wooden bridges stand upon the sounding-box, and through these pass the protruding ends of the needle, whilst an upper box or lid, hinged to the

lower at the back, is added above. Figs. [22](#) and [23](#) show this form, the former being reproduced from Reis's own Prospectus (see p. 85), the latter being from Müller-Pouillet's 'Text-book of Physics' (see p. 95). Herr Albert, mechanician, of Frankfort, who made and sold the Reis telephones, says that the upper box was added at his suggestion. Originally it was so constructed (see [Fig. 22](#)), that when closed it pressed upon the steel needle. In the instruments of later date, the notches which fitted over the needle were cut so deeply (see [Fig. 23](#)), that the lid did not press upon the wire. Reis's own instructions are (see p. 86) that the sound is intensified by firmly pressing the lid against the needle, as was done occasionally by the listeners who pressed their ears against the lid in order to hear more distinctly. The little key seen at the end of the sounding-box, in [Fig. 22](#), was used for interrupting the current and so to telegraph back signals to the transmitter.

CHAPTER III.

THE CLAIM OF THE INVENTOR.

In the present century, when so many facilities exist for the diffusion of knowledge, and when every new discovery and invention is eagerly welcomed and immediately noised abroad to every country of the globe, it is hard to believe that the inventor of an instrument of the highest scientific value, destined to play an important part in social and commercial life, should have been suffered to live and die in unrecognised obscurity. Still harder is it to believe that his invention passed into almost complete oblivion, unacknowledged by most of the leading scientific men of his day and generation. But hardest of all is it to believe that when at last attempts were made to give to him, whose name and fame had thus been permitted to languish, the credit of the splendid researches in which he wore his life away, those attempts could be met on the one hand by an almost complete apathy, and on the other by a chorus of denial, not only that any such invention was made, but that the inventor had ever intended to invent anything of the kind. Yet nothing less than this has happened. Philipp Reis, the inventor of the Telephone, the first to scheme, and carry out into execution, an instrument for conveying to a distance by means of electric currents the tones of human speech and human song, is no longer amongst the living. He cannot reclaim for himself the honours that have been showered upon the heads of others, who, however worthy of those honours they were—none will deny that—were only not the first to deserve them. In his quiet grave, in the obscurity of the German village where his daily work was done, he sleeps undisturbed by the strife of tongues. To him it matters nothing now, whether his genius be recognised and his invention applauded, or whether ignorance, and calumny, and envy, alike decry both. Nevertheless, the memory of him and of his work will live, and will descend to posterity as of one whom his own generation knew not, whose peculiar greatness passed unheeded save by a chosen few. Nor will posterity be the less ready to accord *honour* to him who in his own

day could not even obtain justice. Yet something more than a mere historic justice for the poor schoolmaster of Friedrichsdorf does the world owe; justice to the great invention that is now imperishably associated with his name: justice to the struggling family whom, instead of enriching, it impoverished; and, not least, the justice of patience, whilst the story of his life and work, and the words he himself has written thereupon, are unfolded.

The point at issue, and for which justice has been invoked, and of which ample proof is given in these pages, is not whether Philipp Reis invented *a* telephone—that is not denied—but whether Philipp Reis invented *the* Telephone. The irony of fate, not to say the curious ignorance which is often called by a less polite name, has decreed by the mouth of popular scientific writers, of eminent engineers, and of accomplished barristers, that Reis's invention was not an instrument for transmitting human speech at all—was not intended even for this—that it was a purely musical instrument in its inception, and that it has always so remained. These clever persons begin to persuade themselves of this view, and forthwith invent a question-begging epithet, and dub the instrument as a mere “*tone-telephone*”! If some unprejudiced person ventures to speak of Reis's instrument as having, as a matter of history, transmitted speech, all the contemptuous reply that he gets from the eminent somebody, who poses as an authority for the moment, is: *Oh, but, you know, it was only a tone-telephone, a musical toy, and when some one was singing to it you fancied you caught the words of the song which, during singing, were occasionally projected along with the music. I've always regarded the accounts of its transmission of speech as a good joke; all it could possibly do was occasionally to utter an articulate noise in combination with a musical tone. Besides, you know, Mr. Reis was a musical man, who only intended it to sing, and if it spoke it only spoke by accident; but such an accident never did or could occur, because the construction of it shows that it not only did not but could not transmit speech. If Mr. Reis had really penetrated the fundamental principle of the articulating telephone, he would have arranged his instruments very differently; and then, you know, if he really had transmitted speech the discovery would have attracted so much attention at the time. Moreover, if he had meant it to talk, he would have called it the articulating telephone, and not a telephone for transmitting tones, you know; no one*

before Graham Bell ever dreamed of using a tympanum to catch articulate sounds, or had he done so he would have been laughed at.

To all such clap-trap as this—and there has been enough *ad nauseam* of such—the one reply is silence, and a mute appeal to the original writings of Reis and his contemporaries, and to the tangible witness of inexorable scientific facts. All the most important of these will be found in their appropriate places. They amply establish the following points:—

I.—Reis’s Telephone *was expressly intended to transmit speech.*

II.—Reis’s Telephone, *in the hands of Reis and his contemporaries, did transmit speech.*

III.—Reis’s Telephone *will transmit speech.*

Before proceeding to discuss these three points we will pause for a moment, first to clear away a lurking verbal fallacy, then to point out the partial historic acknowledgment already conceded to Reis’s claims.

Reis did not call his instrument an “*articulating telephone.*” Neither did he call it a “*tone telephone.*” He called it simply “*The Telephone*” (Das Telephon),^[6] as will be seen in his own first memoir (p. 57). He did speak of his instrument again and again as an instrument “*for reproducing tones.*” But it must be remembered that the German word *Ton* (plural *Töne*) used by Reis is more nearly equivalent to our English word “sound,” and includes articulate as well as musical tones, unless the context expressly indicates otherwise. So that when Reis talked of the *Reproduction of Tones* he was using words which did not limit his meaning to musical tones, as indeed his memoirs show in other ways. He started from a consideration of the mechanical structure of the human ear, and endeavoured to construct an instrument on those lines because the ear can take up *all* kinds of tones. Reis was not so foolish as to imagine that the construction of the human ear was solely designed for musical, to the exclusion of articulate tones. We are not aware that the epithet, Tone-Telephone, was ever applied to Reis’s instruments until it became advisable(!) to seek a means of disparaging an old invention in order to exalt a new one. And it is a curious point that the true musical “tone-telephones,” *i.e.* instruments designed expressly to transmit specific musical tones for the purpose of multiple telegraphy, were invented (by Varley, Gray, La Cour, Graham Bell, and Edison) long after

Reis's Telephone, between the years 1870 and 1876. All these were dependent practically upon the tuning-fork system of vibration, whereas Reis's system was based on the tympanum of the ear. To classify Reis's invention with these would be absurd.

Having shown the fallacy bound up in the term "tone-telephone," we will dismiss the point with the remark that henceforth it will be a waste of time to argue with any person who applies that question-begging epithet to Reis's invention.

Partial historic acknowledgments of Reis's claims as inventor of The Telephone have been made from time to time by those best qualified to speak.

Mr. Edison, the inventor of the famous lamp-black button transmitter, which he christened later as "The Carbon Telephone," has himself stated in his account of his inventions,^[7] that he was started upon this line of investigation by having put into his hand, by the late Hon. Mr. W. Orton, a manuscript translation of Legat's Report on Reis's Telephone, given in the Journal of the Austro-German Telegraph Union (see Translation, p. 70). So that he was, therefore, aware at least of this: that in Reis's instruments "single words uttered, as in reading, speaking, and the like, were perceptible indistinctly, nevertheless, here also the inflexions of the voice, the modulations of interrogation, exclamation, wonder, command, etc., attained distinct expression." So far as Mr. Edison is concerned, therefore, Reis is his starting-point by his own direct avowal.

Professor Graham Bell has not failed to acknowledge his indebtedness to Reis, whose entry "into the field of telephonic research" he explicitly draws attention to by name, in his "Researches in Electric Telephony," read before the American Academy of Sciences and Arts, in May 1876, and repeated almost verbatim before the Society of Telegraph Engineers, in November 1877. In the latter, as printed at the time, Professor Bell gave references to the researches of Reis, to the original paper in Dingler's 'Polytechnic Journal' (see Translation, p. 61); to the particular pages of Kuhn's volume in Karsten's 'Encyclopædia' (see p. 106), in which diagrams and descriptions of two forms of Reis's Telephone are given; and where mention is also made of the success with which exclamatory and other articulate intonations of the voice were transmitted by one of these instruments; and to Legat's Report,

mentioned above (and given in full on p. 70). Professor Bell has, moreover, in judicial examination before one of the United States Courts expressly and candidly stated,^[8] that whilst the receivers of his own early tone-telephones were constructed so as to respond to one musical note only, the receiver of Reis's instrument, shown in Legat's Report (as copied in Prescott's 'Speaking Telephone,' p. 10), and given on p. 109 of this work, was adapted to receive tones of any pitch, and not of one tone only. It is further important to note that in Professor Bell's British Patent he does not lay claim to be the inventor, but only the improver of an invention: the exact title of his patent is, "*Improvements in Electric Telephony (Transmitting or causing sounds for Telegraphing Messages) and Telephonic Apparatus.*"

So far as Professor Bell is concerned, therefore, he is guiltless of stigmatising the Reis instrument as a mere "tone-telephone."

Professor Dolbear, the inventor of the "Static Receiver" form of Telephone, is still more explicit in avowing Reis's claim. In the report of his paper on "the Telephone," read, March 1882, before the Society of Telegraph Engineers and of Electricians^[9] we find: "The speaker could testify that the instrument would talk, and would talk well. The identical instruments employed by Reis would do that, so that Reis's transmitters would transmit. Secondly, his receiver would receive; and Reis did transmit and receive articulate speech with such instruments."

As far as Professor Dolbear is concerned, therefore, he admits in unequivocal terms the whole claim of Reis to be the inventor of *The Telephone*.

Count du Moncel, author of a work on the Telephone, which has run through several editions, though he has classified Reis's instrument as a mere "tone-telephone," has recently admitted^[10] that he was, until the year 1882, ignorant of some of Reis's instruments and of his original papers. He has, moreover, added these words: "Nevertheless, it would not be just not to acknowledge that the Reis Telephone *formed the starting-point of all the others;*" also these significant lines: "It is probable that in this matter, as in the greater number of modern inventions, the *original inventor* obtained only insignificant results, and that it was the man who first succeeded in arranging his apparatus so as

to obtain really striking results that received the honour of the discovery and rendered it popular.”

So far as the Count du Moncel is concerned, therefore, the claims of Philipp Reis to be the inventor of the telephone are admitted, though hesitatingly, to be historically just.

We now return to the proof of the three points previously enunciated.

I.—Reis’s Telephone was expressly intended to transmit speech.

Reis’s first instrument was (see p. 16) nothing else than a model of the mechanism of the human ear. Why did he choose this fundamental type which runs through all his instruments from first to last? The reason is given in his own first memoir (p. 51), “*How could a single instrument reproduce at once the total actions of all the organs operated in human speech? This was ever the cardinal question.*” Reis constructed his instrument therefore with intent to reproduce human speech. For this reason he borrowed from the ear the suggestion of a *tympanum*. Of the operation of the tympanum he had the most exact and perfect conception. He says (p. 54), “*Every tone, and every combination of tones*”—and this includes articulate tones, of course, and is just as true of them as of any other kind—“*evokes in our ear, if it enters it, vibrations of the drum-skin, the motions of which may be represented by a curve.*” And further: “*As soon, therefore, as it shall become possible, at any place and in any prescribed manner, to set up vibrations whose curves are like those of any given tone, or combination of tones, we shall then receive the same impression as that tone or combination of tones would have produced upon us.*” Again, it is clear that his study of acoustics led him to employ the tympanum, because of its special value in responding to all the complex vibrations of human speech. It is no less significant that when a decade later Varley, Gray, and Bell, set themselves to invent tone-telephones for the purpose of multiple telegraphy, they abandoned tympanums as being *unsuitable* for tone-telephones, and in lieu thereof employed vibrating tongues like those of tuning-forks. Reis’s use of the tympanum had a very definite meaning then; it meant nothing less than this: I intend my instrument to transmit any sound that a human ear can hear. That it was explicitly within his intention to transmit speech is

confirmed by another passage of his first memoir (p. 58), wherein he remarks with a shade of disappointment that though “the consonants are for the most part tolerably distinctly reproduced, the vowels are not yet to an equal degree.” To his own pupils and co-workers he communicated his ideas. One of the former, Mr. E. Horkheimer, now of Manchester, expressly says (see p. 117) that Reis’s intention was to transmit speech, and that the transmission of music was an afterthought adopted for the convenience of public exhibition, just as was the case with the public exhibitions of Bell’s Telephone fifteen years later.

Nor did this imperfection cause Reis to hide his intentions from the world. He modestly claimed such success as he had obtained, and left the rest. In 1863 he drew up a Prospectus (given in extenso on p. 85), which was printed to accompany the instruments which were sold; and of which copies are still extant. In this document he says: “Besides the human voice, according to my experience, there can also be reproduced the tones of good organ pipes, from F to c”, and those of a piano.” In this same Prospectus (p. 87) occur the instructions for the use of the signal call by which the listener communicates his wishes to the speaker. Those instructions run: “One beat = *sing*; two beats = *speak*.” Can any sane person doubt that Reis intended his instrument to transmit speech, when such directions stand printed in his own Prospectus? Legat’s Report (1862) speaks of Reis’s instrument as intended (see p. 77) to speak, and further describes the use of an elliptic cavity to which the listener can apply his ear. Kuhn (1866) (see p. 106) says that the square-box transmitter (Figs. [17](#), [18](#)) did not send speech well, and complains that he could only get from it an indistinguishable noise. Doubtless he spoke too loudly, Pisko (1865) speaks of the Reis instrument as intended for speaking (p. 105). Further, in the letter which Reis wrote in 1863 to Mr. W. Ladd, of London, he expressly emphasises by underscoring the word that his Telephone can transmit “*any* sound” that is sufficiently loud, and he refers to the speaker and listener at the two ends of the line as “the correspondents.” The only reply henceforth possible to any person who shall assert that Reis’s Telephone was not expressly intended to transmit articulate speech is the good honest retort: *impudentissime mentiris*.

II.—Reis’s Telephone, in the hands of Reis and his contemporaries, did transmit speech.

Of the performance of his instruments Reis speaks modestly and carefully, nothing extenuating of his failures, nothing exaggerating of his successes. I shall not attempt to be wiser than he; nor seek to make out his instrument to have been either more perfect or more reliable than he himself knew it to be. The membrane tympanum of his transmitter was liable to become relaxed by the moisture of the breath rendering the instrument—as Graham Bell found fifteen years later with his membrane magneto-transmitters—uncertain in its action. Moreover, in some earlier forms of Reis’s transmitter, notably those with a vertical tympanum, the adjustment of the contact-points that controlled the current was a matter of delicacy requiring experience and practice, so that casual experimenters failed to obtain the results which Reis himself obtained; [11] they obtaining only a noisy snarl where he obtained intelligible speech. Lastly, the very delicacy of the essential parts, the conducting strips of metal which lay lightly in contact against one another, militated against a uniformity of success when tried with different voices, some of which were too low to produce any effect, others so loud as to rattle the delicate contact-pieces in a manner fatal to the attainment of the desired result.

In spite of all these drawbacks, which were not inherent in the principle of the instrument, there is plenty of evidence that *Reis’s Telephone did transmit speech*. Reis himself records this fact:

(1.) In 1861, in his memoir ‘On Telephony’ (see p. 58), “*The consonants are for the most part tolerably distinctly reproduced, but the vowels not yet in an equal degree.*”

(2.) In his ‘Prospectus’ (p. 86) Reis says that the tones of organ-pipes and of the piano can be reproduced as well as the tones of the human voice, “*according to my experience.*”

(3.) The fact is attested by Inspector Wilhelm von Legat, in his Report in the ‘Zeitschrift’ (p. 77), 1862. After alluding to the indistinctness of the vowels, he says: “*Single words, uttered as in reading, speaking, and the like, were perceptible indistinctly, nevertheless, here also the inflexions of the voice, the modulations of interrogation, exclamation, wonder, command, etc., attained distinct expression.*”

(4.) Professor Quincke, of Heidelberg, testifies (see p. 113) that he heard and understood words spoken through a Reis Telephone in 1864.

(5.) Professor Böttger, editor of the 'Polytechnisches Notizblatt,' in 1863 says (see p. 90): "The experimenters could even communicate words to one another, though certainly indeed, only such as had often been heard by them."

(6.) Dr. Rudolph Messel, an old pupil of Reis, and an eye-witness of his early experiments, has written^[12]: "There is not a shadow of a doubt about Reis having actually achieved imperfect articulation. *I personally recollect this very distinctly*, and could find you plenty more people who witnessed the same."

(7.) Herr Peter, a former colleague of Philipp Reis, whose testimony will be found on page 126, narrates how he doubted the powers of the instrument until he had verified them for himself by speaking into it words which could not possibly be premeditated.

(8.) Mr. E. Horkheimer, who aided Reis in his earlier work, though he left Germany when the development of the instrument was yet very far from complete, has even given (see p. 117) a list of the words and expressions which he has heard transmitted by the earlier forms of the instrument.

(9.) Herr Philipp Schmidt, brother-in-law of Philipp Reis, and now acting-paymaster in the Imperial German Navy at Wilhelmshavn, says: "he succeeded finally in reproducing at a distance, words and whole sentences." "There never was any understanding between my brother-in-law and myself as to particular words and sentences: on the contrary, these were quite spontaneous."

(10.) Mr. S. M. Yeates, of Dublin, who in 1865 constructed a modified Reis Telephone (see p. 128), has thus described the performance of the instrument: "Before disposing of the apparatus, I showed it at the November meeting (1865) of the Dublin Philosophical Society, when both singing *and the distinct articulation of several words were heard through it, and the difference between the speakers' voices clearly recognised.*"^[13]

It is difficult to conceive how testimony on this point could be stronger. From so many different sources it is alike agreed that—with the instrument presumably in good adjustment—*Reis's Telephone*, in the hands of Reis and his contemporaries, *did transmit articulate speech*.

III.—Reis's Telephone will transmit speech.

Reis's Telephone consists of two parts: a "transmitter," into which the speaker speaks; and a "receiver," at which the hearer listens. Their various forms have been described in detail in the preceding chapter. All that we are concerned with at this place is, whether these instruments will at the present day do what is asserted. The writer has tested every form of Reis's transmitter, save only some of the tentative historic forms shown in Figs. [2-8](#), [13](#), [15](#), & [16](#), *ante*, and has found them perfectly competent to transmit speech, provided proper precautions were taken: namely, that the contacts were clean and in adjustment, that the tympanum was tightly stretched, and that the speaker did not speak too loudly:^[14] in other words, that the instruments were properly used. Any one who wants *not to succeed* in transmitting speech with Reis's transmitter has only to neglect these reasonable precautions. It is not, therefore, difficult to fail. The writer has also tested both the better-known forms of Reis's receiver (Figs. [21](#), [22](#), & [23](#)), and finds that both are perfectly competent to receive speech electrically and reproduce it audibly, both vowels and consonants being perfectly distinct and articulate, though never as loud as in more modern forms of telephone-receiver. From a steel wire, magnetised, as prescribed by Reis, by surrounding it with a coil of wire through which the current passes, the writer has obtained articulation exceeding in perfection of definition, both of vowels and of consonants, the articulation of any other telephone-receiver he has ever listened to. Perhaps it may be objected that it is difficult to listen to a steel wire. Reis met this difficulty in his own way by mounting his steel wire upon a small sounding-box to strengthen the sounds, and added a flat upper case against which the ear of the listener can be pressed, and which can be removed, or opened as a lid, when a whole audience is to hear simultaneously the tones of the instrument when working in a loud and disagreeable manner, as a transmitter of the coarser vibrations of a loudly sung melody. The lid is

not wanted for this latter purpose—is an encumbrance; which, nevertheless, by its presence proves the more delicate functions of the instrument. Reis's instructions in his 'Prospectus,' p. 86, are that pressing this lid down firmly upon the steel core increases the loudness of the sounds. Any one who wants *not to succeed* in receiving speech with Reis's receiver has, as before, only to neglect reasonable precautions. He has only to use an imperfect or bad transmitter, or use it carelessly, or put the receiver to a sufficient distance from his ear, to attain this result. There are people who have failed to make Reis's receiver receive.

This is not the place to discuss a doctrinaire objection sometimes raised, that it is theoretically impossible for Reis's instruments to work. For the moment we are concerned with the practical question: Do they work? No one practically experienced in telephones, even if he should deny that Reis had any such intention, will dispute that they can now be made to transmit speech. Professor Dolbear, himself no mean authority on telephones, testifies, as quoted above (p. 41), "that *the instruments would talk, and would talk well.*" He would, indeed, be a bold man who would come forward to deny what can be shown any day as an experimental fact: that *Reis's Telephone will transmit speech.*

We have now shown that Philipp Reis was the undisputed inventor of an instrument which he called the Telephone, which instrument can now be used to transmit speech; which was then used to transmit speech; and which was invented on purpose to transmit speech. So far the result of the examination into the facts of the case is conclusive enough. A more complete case could hardly be desired. No honest person could hesitate for want of proof, either greater in amount or more direct to the point.

Nevertheless, I propose in another section to go a little further and to prove a technical point of highest interest; namely, that there is not in the Telephone Exchanges of England to-day, any single telephone to be found in which the fundamental principles of Reis's Telephone are not the essential and indispensable features. These considerations being, however, of a strictly technical nature, will be best considered in an Appendix. As, however, we are able to show that those instruments which are now in daily use for transmitting speech, embody the two fundamental principles upon which Reis based the instrument which he called "*Das Telephon,*" it would be dishonest to the memory of the

deceased inventor to claim anything less than that he was the “first and true inventor” of the Telephone.

CHAPTER IV. CONTEMPORARY DOCUMENTS.

The following documents, drawn from the scientific literature of the time, are placed in chronological order, beginning with the first memoir published by Philipp Reis himself, in the *Jahresbericht* of the Physical Society of Frankfort, for the year 1860-61. Every care has been taken that the translations here given shall be faithful in every detail to the originals. All notes and comments by the translator are distinguished by being enclosed in square brackets.

[1.] ON TELEPHONY BY THE GALVANIC CURRENT. *By* PHILIPP REIS.

[Translated from the Annual Report (*Jahresbericht*) of the Physical Society of Frankfurt-am-Main, for 1860-1861.]

The surprising results in the domain of Telegraphy, have often already suggested the question whether it may not also be possible to communicate the very tones of speech direct to a distance. Researches aiming in this direction have not, however, up to the present time, been able to show any tolerably satisfactory result, because the vibrations of the media through which sound is conducted, soon fall off so greatly in their intensity that they are no longer perceptible to our senses.

A *reproduction* of the tones at some distance by means of the galvanic current, has perhaps been contemplated; but at all events the practical solution of this problem has been most doubted by exactly the very persons who by their knowledge and resources should have been enabled to grasp the problem. To one who is only superficially acquainted with the doctrines of Physics, the problem, if indeed he becomes acquainted with it, appears to offer far fewer points of difficulty because he does not foresee most of them. Thus did I, some nine years ago (with a great *penchant* for what was new, but with only too imperfect knowledge in Physics), have the boldness to wish to solve the problem mentioned; but I was soon obliged to

relinquish it, because the very first inquiry convinced me firmly of the impossibility of the solution.

Later, after further studies and much experience, I perceived that my first investigation had been very crude and by no means conclusive: but I did not resume the question seriously then, because I did not feel myself sufficiently developed to overcome the obstacles of the path to be trodden.

Youthful impressions are, however, strong and not easily effaced. I could not, in spite of every protest of my reason, banish from my thoughts that first inquiry and its occasion; and so it happened that, half without intending it, in many a leisure hour the youthful project was taken up again, the difficulties and the means of vanquishing them were weighed,—and yet not the first step towards an experiment taken.

How could a single instrument reproduce, at once, the total actions of all the organs operated in human speech? This was ever the cardinal question. At last I came by accident to put the question in another way: How does *our ear* take cognizance of the total vibrations of all the simultaneously operant organs of speech? Or, to put it more generally: How do we perceive the vibrations of several bodies emitting sounds simultaneously?

In order to answer this question, we will next see what must happen in order that we may perceive a single tone.

Apart from our ear, every tone is nothing more than the condensation and rarefaction of a body repeated several times in a second (at least seven to eight times^[15]). If this occurs in the same medium (the air) as that with which we are surrounded, then the membrane of our ear will be compressed toward the drum-cavity by every condensation, so that in the succeeding rarefaction it moves back in the opposite direction. These vibrations occasion a lifting-up and a falling-down of the “hammer” [*malleus* bone] upon the “anvil” [*incus* bone] with the same velocity, or, according to others, occasion an approach and a recession of the atoms of the auditory ossicles, and give rise, therefore, to exactly the same number of concussions in the fluid of the *cochlæa*, in which the auditory nerve and its terminals are spread out. The greater the condensation of the sound-conducting medium at any given moment, the greater will be the amplitude of vibration of the membrane and of the “hammer,” and the more powerful, therefore, the blow on the “anvil” and the concussion of the nerves through the intermediary action of the fluid.

The function of the organs of hearing, therefore, is to impart faithfully to the auditory nerve, every condensation and rarefaction occurring in the surrounding medium. The function of the auditory nerve is to bring to our consciousness the vibrations of matter resulting at the given time, both according to their number and their magnitude. Here, first, certain combinations acquire a distinct name: here, first the vibrations become musical *tones* or *discords* (Misstöne).

That which is perceived by the auditory nerve, is, therefore, merely the action of a *force* affecting our consciousness, and as such may be represented graphically, according to its duration and magnitude, by a curve.



Fig. 24.

Let the line *a, b*, indicate any given length of time, and the curve above the line a condensation (+), the curve below the line a rarefaction (-), then every ordinate erected at the end of an abscissa will give [according to the height of it], at a moment indicated by the position of the foot of the ordinate, the strength of the condensation that is causing the drum-skin to vibrate.

Our ear can perceive absolutely nothing more than is capable of being represented by similar curves, and this method is completely sufficient to bring before our clear consciousness every tone and every combination of tones.

If several tones are produced at the same time, then the medium that conducts sound is placed under the influence of several simultaneous forces; and the two following laws hold good:—

If all the forces operate in the same sense, the resultant motion is proportional in magnitude to the sum of the forces.

If the forces operate in opposite senses, the resultant motion is proportional in magnitude to the difference of the opposing forces.

Let us exhibit the condensation-curves for three tones—each singly (Table I.)^[16]: then, by adding together the ordinates corresponding to equal

abscissæ, we can determine new ordinates and develop a new curve which we may call the combination-curve [or resultant curve]. Now this gives us just exactly what our ear perceives from the three simultaneous tones. It ought to cause us as little wonder that a musician can recognize the three tones, as that (as is the fact) a person conversant with the science of colour, can recognize in green, blue and yellow tints. The combination-curves of table I. present, however, very little difficulty, since in them all the proportions of the component curves recur successively. In chords consisting of more than three tones (Table II.), the proportions of the components are no longer so easy to recognize in the drawing. But it is also difficult to an accomplished musician, in such chords to recognize the individual notes.

Table III. shows us a discord. Why discords affect us so unpleasantly I leave provisionally to the contemplation of the gentle reader, as I may perhaps return to this point in another memoir.

It follows from the preceding that:—

(1.) Every tone and every combination of tones evokes in our ear, if it enters it, vibrations of the drum-skin, the motions of which may be represented by a curve.^[17]

(2.) The motions of these vibrations evoke in us the perception (sensation) of the tone: and every change in the motion must change the sensation.

As soon, therefore, as it shall be possible at any place and in any prescribed manner, to set up vibrations whose curves are like those of any given tone or combination of tones, we shall receive the same impression as that tone or combination of tones would have produced upon us.^[18]

Taking my stand on the preceding principles, I have succeeded in constructing an apparatus by means of which I am in a position to reproduce the tones of divers instruments, yes, and even to a certain degree the human voice. It is very simple, and can be clearly explained in the sequel, by aid of the figure:

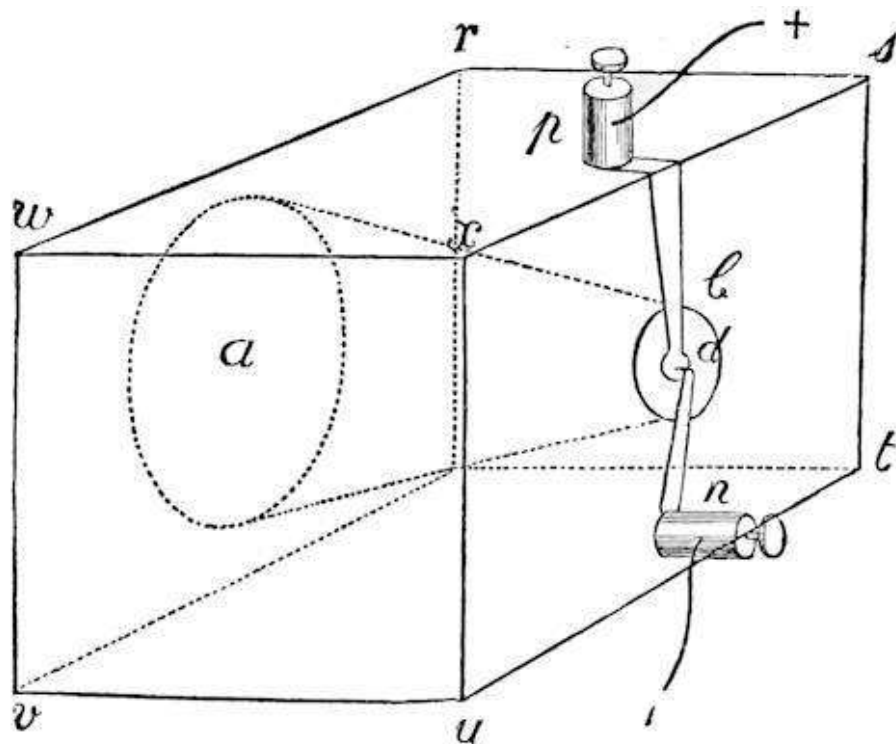

Fig. 25.

In a cube of wood, $r s t u v w x$, there is a conical hole, a , closed at one side by the membrane b (made of the lesser intestine of the pig), upon the middle of which a little strip of platinum is cemented as a conductor of the current [or electrode]. This is united with the binding-screw, p . From the binding-screw n there passes likewise a thin strip of metal over the middle of the membrane, and terminates here in a little platinum wire which stands at right angles to the length and breadth of the strip.

From the binding-screw, p , a conducting-wire leads through the battery to a distant station, ends there in a spiral of copper-wire, overspun with silk, which in turn passes into a return-wire that leads to the binding-screw, n .

The spiral at the distant station is about six inches long, consists of six layers of thin wire, and receives into its middle as a core a knitting-needle, which projects about two inches at each side. By the projecting ends of the wire the spiral rests upon two bridges of a sounding-box. (This whole piece may naturally be replaced by any apparatus by means of which one produces the well-known "galvanic tones.")

If now tones, or combinations of tones, are produced in the neighbourhood of the cube, so that waves of sufficient strength enter the opening a , they will set the membrane b in vibration. At the first condensation the hammer-shaped little wire d will be pushed back. At the succeeding rarefaction it cannot follow the return-vibration of the

membrane, and the current going through the little strip [of platinum] remains interrupted so long as until the membrane, driven by a new condensation, presses the little strip (coming from p) against d once more. In this way each sound-wave effects an opening and a closing of the current.

But at every closing of the circuit the atoms of the iron needle lying in the distant spiral are pushed asunder from one another. (Müller-Pouillet, 'Lehrbuch der Physik,' see p. 304 of vol. ii. 5th ed.). At the interruption of the current the atoms again attempt to regain their position of equilibrium. If this happens then in consequence of the action and reaction of elasticity and traction, they make a certain number of vibrations, and yield the longitudinal tone^[19] of the needle. It happens thus when the interruptions and restorations of the current are effected relatively slowly. But if these actions follow one another more rapidly than the oscillations due to the elasticity of the iron core, then the atoms cannot travel their entire paths. The paths travelled over become shorter the more rapidly the interruptions occur, and in proportion to their frequency. The iron needle emits no longer its longitudinal tone, but a tone whose pitch corresponds to the number of interruptions (in a given time). But this is saying nothing less than that *the needle reproduces the tone which was imparted to the interrupting apparatus.*

Moreover, the strength of this tone is proportional to the original tone, for the stronger this is, the greater will be the movement of the drum-skin, the greater therefore the movement of the little hammer, the greater finally the length of time during which the circuit remains open, and consequently the greater, up to a certain limit, the movement of the atoms in the reproducing wire [the knitting needle], which we perceive as a stronger vibration, just as we should have perceived the original wave.

Since the length of the conducting wire may be extended for this purpose, just as far as in direct telegraphy, I give to my instrument the name "*Telephon.*"

As to the performance attained by the Telephone, let it be remarked, that, with its aid, I was in a position to make audible to the members of a numerous assembly (the Physical Society of Frankfort-on-the-Main) melodies which were sung (not very loudly) into the apparatus in another house (about three hundred feet distant) with closed doors.

Other researches show that the sounding-rod [i.e. the knitting needle] is able to reproduce complete triad chords ("Dreiklänge") of a piano on which

the telephone [i.e. the transmitter] stands; and that, finally, it reproduces equally well the tones of other instruments—harmonica, clarinet, horn, organ-pipes, &c., always provided that the tones belong to a certain range between F and f ”^[20].

It is, of course, understood that in all researches it was sufficiently ascertained that the direct *conduction* of the sound did not come into play. This point may be controlled very simply by arranging at times a good shunt-circuit directly across the spiral [i.e. to cut the receiving instrument out of circuit by providing another path for the currents of electricity], whereby naturally the operation of the latter momentarily ceases.

Until now it has not been possible to reproduce the tones of human speech with a distinctness to satisfy everybody. The consonants are for the most part tolerably distinctly reproduced, but the vowels not yet in an equal degree. Why this is so I will endeavour to explain.

According to the researches of Willis, Helmholtz, and others, vowel sounds can be artificially produced by causing the vibrations of one body to reinforce those of another periodically, somewhat after the following scheme:—

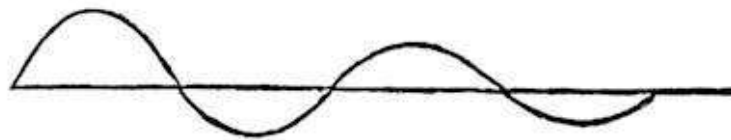

Fig. 26.

An elastic spring is set in vibration by the thrust of the tooth of a cog-wheel: the first swing is the greatest, and each of the others is less than the preceding one (see [Fig. 26](#)).

After several vibrations of this sort (without the spring coming to rest) let another thrust be given by the tooth; the next swing will again be a maximum one, and so on.

The height or depth of the sound produced in this fashion depends upon the number of vibrations made in a given time; but the quality of the note depends upon the number of variations of amplitude (*Anschwellungen*) occurring in the same time.

Two vowels of equal pitch may be distinguished from each other somewhat after the manner represented by the curves (1) (2): while the same tone devoid of any vowel quality, is represented by curve (3).

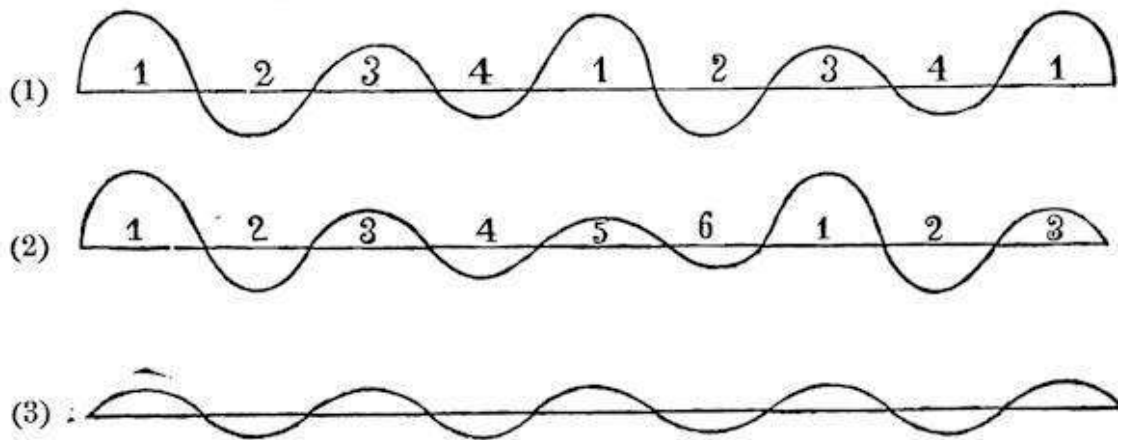

Fig. 27.

Our organs of speech create the vowels probably in the same manner by a combined action of the upper and lower vocal chords, or of the latter and of the cavity of the mouth.

Now my apparatus gives the number of the vibrations, but with far less strength than the original ones; though also, as I have cause to think, always proportional to one another up to a certain degree. But because the vibrations are throughout smaller, the difference between large and small vibrations is much more difficult to recognize than in the original waves, and the vowel is therefore more or less indefinite.

Whether my views with respect to the curves representing combinations of tones are correct, may perhaps be determined by aid of the new phonautograph described by Duhamel. (See Vierordt's 'Physiology,' p. 254.)

There may probably remain much more yet to be done for the utilisation of the telephone in practice (zur praktischen Verwerthung des Telephons). For physics, however, it has already sufficient interest in that it has *opened out* a new field of labour.

PHILIPP REIS.

Friedrichsdorf, near Frankfort-on-the-Main,
in December 1861.

[Though the foregoing memoir, as printed in the 'Jahresbericht,' of the Physical Society of Frankfort-on-the-Main, is dated "December 1861," it was delivered verbally on October 26th preceding, as the 'Proceedings' of the Society show. From the 'Jahresbericht' for the succeeding year we learn that three weeks after the delivery of this communication Reis made a

second communication to the Society on a kindred matter. The entry is as follows ('Proceedings' of the Society, p. 13): "On the 16th November, by the same: Explanation of a new Theory concerning the Perception of Chords and of Timbre ('Klangfarben'), as a Continuation and Supplement of the Memoir on the Telephone." So far as can now be learned, the substance of this communication was embodied in the latter part of the paper "On Telephony," when written out in December for publication. On the 8th of January, 1862, the formal thanks of the Society were voted to Reis for the manuscript which he had contributed to the 'Jahresbericht.'

It is of interest, moreover, to note that the matter did not immediately drop. Professor Böttger, who as one of the regular lecturers of the Physical Society, held fortnightly discourses on matters of scientific novelty, took occasion on the 7th of December to recur to the subject then attracting so much attention. The title of his discourse (see 'Proceedings' of the Society, p. 11) was "Application of an Experiment relating to the Transmission of Musical Tones to any desired distance by means of the Galvanic Current." It is not quite certain whether Reis was present on this occasion. Early in the spring of 1863, appeared in Böttger's 'Polytechnisches Notizblatt' (No. 6 of that year) an article which contains in condensed form Böttger's discourse. This article was copied into Dingler's 'Polytechnisches Journal' for May 1863. vol. clxviii. p. 185, and also into the 'Polytechnisches Centralblatt' for July 1863, vol. xxix. p. 858. An extract of Reis's own paper, condensed from the 'Jahresbericht' by Dr. Roeber (now President of the Physical Society of Berlin), appeared in the 'Berliner Berichte' (*i. e.* the 'Fortschritte der Physik') for 1861, vol. xvii. pp. 171-173. It is interesting to note that Reis's paper was then deemed worthy to stand in the pages of the 'Fortschritte' by the side of the classic researches of Thomson on Regulation, and of Maxwell on Magnetic Lines of Force. The following is a translation of Böttger's notice mentioned above.]

[2.] ON THE TRANSMISSION OF TONES TO A DISTANCE AS FAR AS DESIRED, BY THE HELP OF ELECTRICITY (TELEPHONY).

[Translated from the original notice by Professor Böttger, which appeared in Böttger's 'Polytechnischen Notizblatt,' 1863, No. 6, p. 81, in Dingler's 'Polytechnisches Journal,' 1863, vol. clxviii. p. 185, and in the 'Polytechnisches Centralblatt,' 1863, t. xxix. p. 858.]

Two decades ago we had not yet gone beyond the first attempts to give signals at a great distance by the aid of electricity. Since then telegraphy has attained such a completeness, and the telegraph wire has reached such a universal extension, that there seems little left for even the boldest wish to desire.

Now there crops up a first serious research to reproduce tones at any desired distance by the aid of electricity. This first experiment which has been crowned with some success, has been made by the teacher of Natural Science at Friedrichsdorf, not far from Frankfort-on-the-Main, Herr Ph. Reis, and has been repeated in the Auditorium of the Physical Society in Frankfort, before numerous assembled members on the 26th of October, 1861. He caused melodies to be sung not very loudly into one part of his apparatus, which was placed in a building (the Bürger-Hospital), about 300 feet distant, with closed windows and doors. These same melodies were *audible* to the members in the meeting-hall by means of the second part of the apparatus. These wonderful results were attained with the following simple pieces of apparatus. A little light box, a sort of hollow cube of wood, has a large opening at its front side, and a small one at the back on the opposite side. The latter is closed with a very fine membrane (of pig's smaller-intestine) which is strained stiff. A narrow springy strip of platinum foil, fixed at its outer part to the wood, touches the membrane at its middle; a second platinum strip is fastened by one of its ends to the wood at another spot, and bears at its other end a fine horizontal spike, which touches the other little platinum strip where it lies upon the membrane.

As is known, tones arise from rarefactions and condensations of the air following quickly after one another. If these motions of the air, known as waves, strike upon the thin membrane, they press it against the little plate of platinum with which it is in contact, and immediately let it vibrate back again into the hollow cube (or so-called artificial ear): they act so that the membrane now takes a form hollowed toward the cube, now bulged toward the outside. The little plate of platinum touching it thereby acquires a vibrating motion, so that it now is pressed against the spike of the second [platinum plate], now leaves the same.

If now one little plate of platinum be united by a wire with one pole of a voltaic battery, and the electricity be led, by a wire fastened to the other pole of the battery, to any desired distance; there carried through a spiral, about six inches long, made of a six-fold winding of very thin covered copper wire; thence led back to the second platinum strip on the wooden

cube through a second insulated wire; then at every vibration of the membrane an interruption in the current of electricity takes place because the platinum point no longer touches the other little strip of platinum. Through the hollow of the wire-spiral there is stuck a thin iron wire (a strong knitting-needle), which is ten inches long, and which rests upon two bridges of a sounding-board by its ends which project on both sides about two inches out of the spiral.

It is known^[21] that if an electric current be led through a spiral which surrounds an iron rod in the manner described, at every interruption of the same a tone is audible arising from the vibration of the rod. If the closings and interruptions of the circuit follow one another relatively slowly, then there is produced by the changes of position of the molecules of the rod, evoked by the electricity, a tone,—the so-called longitudinal tone of the rod,—which is dependent upon the length and stoutness of the rod. But if the closings and interruptions of the electric current in the spiral follow one another more rapidly than the vibrations of the smallest particles of the iron rod,^[22] which vibrations are determined by its elasticity, then these particles cannot complete their paths, receive new impacts, their vibrations become smaller, but quicker, and follow one another as frequently as the interruptions. The iron rod then no longer gives its longitudinal tone, but a tone, which is higher according as the interruptions are more frequent in the given time, or lower, as they are less frequent. It is known that the height and depth of tones depends only on the number of air-waves which follow one another in a second. We have seen above that by this is determined the number of interruptions of the electric current of our apparatus by means of the membrane and the platinum strip. The iron wire must therefore give out the tone in the same height or depth as that which struck the membrane. Now since a very far leading of the electricity makes it suffer scarcely any weakening in proper apparatus, it is intelligible that one can make the tone which acts on the membrane at one place audible, by means of the iron rod, at any desired distance.

That the tone is made audible at a distance by the electric agitations, and not by direct conduction of the sound-waves through the wires is proved in the most evident way of all, because one instantly hears no more the tone through the spiral when a good short circuit is made, as, for example, by laying upon the two wires which conduct the electricity a strip of sheet metal right in front of the spiral.

The reproduced tones are, of course, somewhat weaker than the original ones, but the number of vibrations is similar. If thus the reproduction [of tones] in exactly similar height and depth is easily attained, it is however difficult for our ear, amidst the always smaller vibrations, to which the diminished strength of the tone is due, to evaluate exactly the magnitude of the vibrations. But the character of the tone depends upon the number of variations of amplitude (*Anschwellungen*), that is to say, depends upon whether, for example, in the tones which have similar pitch and therefore a similar number of waves per second, the fourth, sixth, eighth, tenth, or sixteenth wave is stronger than the others. For physicists have shown that an elastic spring is set in vibration by the thrust of the teeth of a cog-wheel; the first vibration is the greatest, all those that follow being less. If there comes, before the spring comes to rest, a fresh thrust from a cog, then the next vibration is again equal to the greatest first vibration without the spring making any more vibrations on that account; and by this means vowel-tones may be artificially produced.

One may also be yet far removed from being able to carry on a conversation with a friend dwelling a hundred miles distant, and recognise his voice, as if he sat near us; but it can no longer be maintained that this is impossible. Indeed the probability that this will be attained^[23] is already become as great as the probability of the reproduction of natural colours in photography has become through the notable researches of Niepce.

[The second public exhibition which Reis made of the telephone was, like the first, in Frankfort-on-the-Main, but this time before a Society known as the *Freies Deutsches Hochstift*, or Free German Institute, a kind of Athenæum Club for the city of Frankfort, now for many years established in the well-known house where the poet Goethe was born, in the Grosse Hirschgraben. In 1862, however, the Free German Institute held its meetings in another building known as the Saalbau. And on May the 11th of that year Philipp Reis lectured upon and exhibited the Telephone. A journal which appeared then, and still appears, in Frankfort, with the title of 'Didaskalia,' devoted to light literary and artistic news, popular science, and general intelligence of an informing character, ordinarily inserted notices of the chief meetings of the Hochstift. On this occasion a preliminary paragraph was inserted in the following terms:—]

[3.] TELEPHONY, *i.e.* SOUND-TRANSMISSION
[TRANSLATION FROM 'DIDASKALIA,' MAY 8TH, 1862.]

The excellent physicist, Mr. Phil. Reis, of Friedrichsdorf, calls by this name his surprising invention for using the telegraph line to transmit really audible tones. Our readers will perhaps remember having heard some time since of this invention, the first trials with which Mr. Reis performed here in the Physical Society. Since then the invention has been constantly developed, and will, no doubt, become of great importance.

[The lecture which followed this announcement was duly given on the 11th of May. In the Saalbau there is a suite of four rooms. The Lecture to the assembled members of the Hochstift was delivered in the Auditorium, at one end of the suite: the wires were passed through the two intervening rooms to the fourth chamber, where the transmitter was placed, the doors being closed. The battery and wires were borrowed from the Physical Society for this occasion, permission for their use having been granted on May 2nd, as appears in a formal entry in the minute-book. The following notice of Reis's discourse, believed to have been written by Dr. Volger, Founder and first President of the Hochstift, appeared in 'Didaskalia' for May 14th.]

[4.] TRANSLATION FROM 'DIDASKALIA,' 12TH MAY, 1862.

Yesterday's meeting of the Free German Institute was a very numerous attended one from the fact that the subject in the order of business, "Telephony by Transmission of the Galvanic Current," as explained by the inventor himself, Mr. Phil. Reis, excites so great an interest that it rightly deserves the most general attention.

In a lecture exceedingly interesting, universally understood, clear, and concise, Mr. Reis gave a historical outline of the origin and development of his idea of the practical possibility of the transmission of tones in a galvanic way.

His first attempts were mostly unsuccessful in solving the cardinal question propounded by him. "How is it possible that a single instrument can reproduce at once the total action of all the organs operated in human speech?" Until finally it occurred to him to seek the solution of the problem in the question, "How does our ear take cognisance of the total vibrations of

all the organs of speech acting at once?” or “How do we perceive the vibrations of several bodies sounding at once?”

In order to answer this question the lecturer went more closely into the anatomy of the ear and into the formation of tones in general. After this was determined, he took up again his experiments in reference to the transmission of tones by means of galvanism.

Afterwards Mr. Reis constructed considerably enlarged the parts of the ear necessary for hearing, by which it was finally possible for him to transmit the tones brought to the mechanically-imitated ear.

The experiments by him some months ago in the Physical Society, were, to the astonishment of all, exceedingly plain and clear, whereas the experiment following the lecture of yesterday was less successful. This was due partly to the poor conductivity of the wires, partly to the locality.

Although much is still left to be done for the practical utilisation (Verwerthung) of the telephone, yet a new and interesting field of labour is hereby opened to physics.

[No more complete report than the foregoing is to be found, and it is believed that the discourse, which like all those given by Reis was delivered extempore, was never committed to writing. Its resemblance to the discourse of the preceding autumn before the Physical Society is great; and indeed it may be said that all Reis's discourses upon the telephone were practically identical in their contents. A few months after this lecture, Reis presented a pair of instruments, transmitter and receiver, to the Hochstift. These instruments were not the same as those used by Reis at his lecture, but were of the “improved” type, whilst those used by Reis at his lecture to the Hochstift, were, so far as respects the transmitter at least, more like the form described by W. von Legat, and figured in [Plate II., Fig. A](#);[24] and according to Mr. Horkheimer, who helped Reis on this occasion, the transmitter was provided with a conical mouthpiece of wood. The transmitter presented later by Reis is of the “square-box” form ([Fig. 17](#)), and is stamped, “1863, Philipp Reis, 2,” and the receiver is of the “knitting-needle” form ([Fig. 23](#)). These instruments are carefully preserved by the Hochstift in the “Goethehaus,” amongst their archives “in everlasting remembrance” of the inventor. A few months later, in 1863, the Emperor of Austria and the late king Max of Bavaria were residing at Frankfurt and visited the “Goethehaus;” and on this occasion Reis's instruments were

shown to these distinguished visitors by the Founder and President of the Hochstift, Dr. Volger.

In honour of his brilliant invention Reis was, shortly after his lecture, elected an honorary member of the Freies Deutsches Hochstift.]

[The next document in order is a Report by Wilhelm von Legat, communicated to the Austro-German Telegraph Union (Verein) in 1862, and printed in the 'Journal' of that Society. It was reprinted verbatim in Dingler's 'Polytechnisches Journal,' for 1863, vol. clxix. p. 29. This Report is of great importance. It is quoted by Graham Bell, in his earliest account of *his* telephone. It was this Report, moreover, which in 1875 or 1876, in a translated manuscript form, was put into Mr. Edison's hands by the then President of the Western Union Telegraph Company, and which formed the starting-point of Edison's subsequent work.]

[5.] ON THE REPRODUCTION OF TONES IN THE ELECTRO-GALVANIC WAY.

By v. LEGAT, Inspector of the Royal Prussian Telegraphs in Cassel.

[Translated from the Journal of the Austro-German Telegraph Society (edited by Dr. Brix), vol. ix. p. 125, 1862. (Zeitschrift des deutschösterreichischen Telegraphen-Vereins, 1862.)]

It might not be uninteresting to make known to wider circles the following ideas concerning the reproduction of tones in an electro-galvanic way, which have recently been put forward by Herr Philipp Reiss [*sic*] of Friedrichsdorf, before the Physical Society, and before the meetings of the Free German Institute (Freies Deutsches Hochstift) in Frankfort-on-the-Main; also to state what has hitherto been attained in the realisation of this project, in order that building upon the collected experiences and the efficacy of the galvanic current, what has already been made serviceable to the human intellect for the advancement of its correspondence, may in this respect also be turned to profit.

In what is here announced we are concerned not with the action of the galvanic current in moving telegraphic apparatus of whatever construction for producing *visible* signals, but with its application for the production of *audible* signals—of *tones*!

The air-waves, which by their action within our ears awaken in us the sensation of sound, by first of all setting the drum-skin into a vibrating motion, are thence, as is known, conveyed to the inner part of the ear and to the auditory nerves lying there by a lever apparatus of the most marvellous fineness,—the auditory ossicles (including “Hammer,” “Anvil,” and “Stirrup”). The experiment for the reproduction of tones is based upon the following: viz. to employ an artificial imitation of this lever-apparatus and to set it in motion by the vibrations of a membrane like the drum-skin in the ear, and thus to open and close a galvanic circuit which is united by a metallic conductor with a distant station.

Before the description of the necessary apparatus is followed out, it might be necessary, however, to go back to the point how our ear perceives the vibrations of a given tone, and the total vibrations of all the tones simultaneously acting upon it; because by this means will be determined the various requisite conditions which must be fulfilled by the transmitting and receiving apparatus for the solution of the problem that has been set.

Let us consider first the processes which take place in order that a single tone should be perceived by the human ear; so shall we find that each tone is the result of a condensation and rarefaction several times repeated in a certain period of time. If this process is going on in the same medium (the air) in which our ear is situated, the membrane will at every condensation be forced toward the hollow of the drum, and at every rarefaction will move itself in the opposite direction.

These vibrations necessitate a similar motion of the auditory ossicles, and thereby a transference to the auditory nerves is effected.

The greater the condensation of a sound-conducting medium at any given moment, the greater also will be the amplitude of vibration of the membrane and of the auditory ossicles and of their action; and in the converse case the action will be proportionally less. It is, therefore, the function of the organs of hearing to communicate with fidelity to the auditory nerves every condensation and rarefaction occurring in the surrounding medium; whilst it remains to be the function of the auditory

nerves to bring to our consciousness the number as well as the magnitude of the vibrations ensuing in a given time.

Here in our consciousness a definite name is given to a certain composition, and here the vibrations brought to the consciousness become “tones.”

That which is perceived by our auditory nerves is consequently the effect upon our consciousness of a force which, according to its duration and magnitude, may for the sake of better comprehension, be exhibited graphically.



Let, for example, the length of the line $a b$ be any definite duration of time, and let the curves above this line denote the condensations (+), and the curves below this line the rarefactions (-); then every ordinate erected at the extremity of an abscissa gives us the strength of the condensation in consequence of which the drum-skin vibrates, at the moment indicated by the position of the foot of the ordinate.

Anything more than that which is exhibited in this way or by similar curves our ear cannot in the least perceive, and this is sufficient to bring to our consciousness each single tone and each given combination of tones. For, if several tones are produced at the same time, the sound-conducting medium is put under the influence of several simultaneously acting forces which are subject to the laws of mechanics.

If all the forces operate in the same sense, then the magnitude of the motion is proportional to the sum of the forces. If the forces act in opposite directions, the magnitude of the motion is proportional to the difference between the opposing forces.

Consequently it is possible out of the condensation-curves of several simultaneously-occurring tones to compound, by the foregoing principles, a condensation-curve which exactly expresses that which our ear experiences on the reception of these simultaneously-acting tones. The objection ordinarily made to this, that a musician, or even any one, is able to hear separately the single tones of which this combined curve is built and constructed, cannot be admitted as a proof to the contrary; for one expert in the science of colour will, for example, in the same way discern in green a mixture of yellow and blue in their various shades: and the one phenomenon equally with the other may be referred back to this; that, to the

person concerned, the factors which make up the product of that which reaches his consciousness are well known.

According to that which has been already explained, it is easy to construct the condensation-curves of various tones, chords, &c., and for the sake of clearness some examples follow:—

[Fig. 1, Plate I,](#)^[25] shows a combination curve of three tones, in which all the proportions of the components recur successively.

[Fig. 2](#) shows such a curve of more than three tones, in which the proportions in the drawing can no longer so evidently be given; yet the practised musician would here recognise them, even although in practice it might be difficult for him to single out, in such chords, the separate tones.

This method of exhibiting the action of tones upon the human ear offers the advantage of a very clear perception of the process; and that which is exhibited ([Fig. 3](#)) shows also why a discord must affect our ear unpleasantly.

This apparent digression from the aim set forth was necessary in order to indicate that as soon as it is possible for us to create anywhere, and in any manner whatever, vibrations whose curves and magnitudes are similar to the vibrations of any given tone, or of any given combination of tones, we shall have the same impression as this original tone or this original combination of tones would have produced upon us.

The apparatus hereafter described offers the possibility of creating these vibrations in every fashion that may be desired, and the employment of electro-galvanism gives us the possibility of calling into life, at any given distance, vibrations similar to the vibrations that have been produced, and in this way to reproduce at any place the tones that have been originated at another place.

In [Fig. 4, Plate II,](#)^[26] herewith presented, A is the transmitter (Tonabgeber), and B the receiver (Tonempfänger), which two instruments are set up at different stations. I make, however, the preliminary remark that the manner of joining the instruments for interchangeable use backward and forward is here omitted for the sake of clearness, and the more so because the whole is not here propounded as a final fact, but in order to bring that which has been hitherto accomplished to the knowledge of a wider circle. The possibility of the working of the apparatus to a greater distance than that which at present limits in practice the direct working of the galvanic

current may also be left out of consideration, since these points may be easily rendered possible by mechanical precautions, and do not affect the essential part of the phenomena now described.

Let us next turn to the transmitter, [Fig. A](#). It is put into communication on one side with the metallic conductor leading to the neighbouring station, and by means of this with the receiver, [Fig. B](#); on the other side it is connected, by means of the electro-motive power, C, with the earth or a metallic return-conductor.

The transmitter, [Fig. A](#), consists of a conical tube, *a b*, of about 15 centimetres length, 10 centimetres in the front, and 4 centimetres in the back aperture.

(In the practical investigations it has been established that the choice of material for this tube is without influence on the use of the apparatus, and moreover a greater length of the same for the certainty [of action] of the apparatus is without effect. A greater width of the cylinder spoils the usefulness of the apparatus; and it is recommended that the interior surface be as smooth as possible.)

The narrow hinder aperture of the cylinder is closed by a membrane, *o*, of collodion, and on the middle of the circular surface formed by this membrane rests one end, *c*, of the lever, *c d*, the fulcrum (point of support), *c*, of which, supported on a bearing, remains joined to the metallic conductor.

The choice of the length of the two arms of the lever, *c e* and *e d*, is determined by the laws of force of levers. It is recommended that the arm, *c e*, be constructed longer than the arm *e d*, in order to bring the smallest movement at *c* into action at *d* with the greatest possible force; but, on the other hand, it is desirable to make the lever itself as light as possible, in order that it may follow the motions of the membrane. An uncertain following of the lever, *c d*, produces impure tones at the receiving station. In the condition of rest the contact, *d g*, is closed, and a delicate spring, *n*, holds the lever firmly in this position of rest.

The second part of this apparatus, the pillar, *f*, consists of a metallic support, which is united with one pole of the battery, C, while the second pole of the battery is carried to the metallic conductor of the other station.

Upon the support, *f*, there is a spring, *g*, with a contact, which corresponds to the contact at *d* of the lever *c d*, and whose position is regulated by a screw, *h*.

In order not to weaken the action of the apparatus by the communication of the air-waves which are produced in using the apparatus, against the back of the membrane, it is recommended, in using the apparatus, to place over the tube, *a b*, at right angles to its longitudinal axis, a screen of about 50 centimetres diameter, which fixes tight upon the outer surface of the tube.

The receiver, [Fig. B](#), consists of an electro-magnet, *m m*, which reposes upon a sounding-box, *u w*, and whose wire coils are respectively connected with the metallic conductor and with the earth or metallic return-conductor.

Opposite the electro-magnet, *m m*, stands an armature, which is connected with a lever, *i*, which is long as possible, but light and broad.

The lever, *i*, is fastened, pendulum-wise, to the support, *k*, and its movements are regulated by the screw, *l*, and the spring, *p*.

In order to improve the action of the apparatus, this receiver can be placed in one focus of an elliptically arched cavity of corresponding size, in which case, then, the ear of him who is listening to the reproduced tones may be placed at the second focus of this cavity.

The action of the two apparatuses here described, is the following:—

In a condition of rest the galvanic circuit is closed.

In the apparatus, [Fig. A](#), by speaking (singing, or leading into it the tones of an instrument) into the tube *a b*, in consequence of the condensation and rarefaction of the air present in this tube, there will be evoked a motion of the membrane closing the tube at its narrow end, corresponding to this condensation or rarefaction. The lever, *c d*, follows the motion of the membrane, and opens and closes the galvanic circuit at *d g*, so that by each condensation of the air in the tube an opening, and at each rarefaction a closing of the galvanic circuit ensues.

In consequence of this process, the electro-magnet of [Fig. B](#) (the receiver) will be demagnetised and magnetised correspondingly with the condensations and rarefactions of the mass of air in the tube *A, a b* [the mouth-piece of the transmitter], and the armature belonging to the magnet will be set into vibrations similar to those of the membrane in the transmitting apparatus. The plank, *i*, connected with the armature, conveys these similar vibrations to the air surrounding the apparatus, [Fig. B](#), which finally transmits to the ear of the listener the tones thus produced.

We are not, therefore, dealing here with a propagation of sound through the electric current, but only with a transference to another place of the

tones that have been produced, by a like cause being brought into play at this second place, and a like effect produced.

Here, however, it must not be overlooked that the preceding apparatus reproduces, indeed, the original vibrations in equal number, but that equal strength in the reproduced vibrations has not yet been attained, and the production of these is reserved for a completion of the apparatus.

One consequence of this temporary incompleteness of the apparatus, is that the slighter differences of the original vibrations are more difficult to discern: that is to say, the vowel appears more or less indistinct, the more so since each tone is dependent, not only on the number of vibrations of the medium, but also on the condensation or rarefaction of the same.

By this it is also explained, that, in the practical investigations heretofore carried on, chords, melodies, etc., were transmitted with marvellous fidelity; while single words uttered as in reading, speaking, and the like, were perceptible more indistinctly. Nevertheless, here also the inflexions of the voice, the modulations of interrogation, exclamation, wonder, command, &c., attained distinct expression.

There remains no doubt, that before expecting a practical utilisation with serviceable results (*praktische Verwerthung mit Nutzen*), that which has been here spoken of will require still considerable improvement, and in particular mechanical science must complete the apparatus to be used; yet I am convinced by repeated practical experiments that the prosecution of the subject here explained is of the highest theoretical interest, and that our intelligent century will not miss the practical utilisation (*Verwerthung*) of it.

[This article was also reprinted verbatim in *Dingler's Polytechnisches Journal*, vol. clxix. p. 29, 1863.]

[A peculiar interest is attached to the foregoing article, partly on account of the unique nature of the instruments therein described, partly because of the mystery attaching to the author of the article. Wilhelm von Legat was Inspector of the Royal Prussian Telegraphs at Cassel. How or when he

became acquainted with Philipp Reis is not known—possibly whilst the latter was performing his year of military service at Cassel in 1855. None of Reis’s intimate friends or colleagues now surviving can give any information as to the nature of von Legat’s relations with Reis, as not even his name is known to them, save from this Report. Yet he was for one year only (1862), the year in which this Report was made, a member of the Physical Society of Frankfort-on-the-Main. It is possible that he may have been present at Reis’s discourse in the preceding October. It is probable that he was present at Reis’s subsequent discourse in May, 1862, to the Freies Deutsches Hochstift. Dr. Brix, then editor of the ‘Journal of the Telegraph Union,’ informs me that Inspector von Legat based his article upon information derived direct from Reis, whom he knew, and that the article was submitted to Reis before being committed to the ‘Journal.’ The particular form of transmitter described in von Legat’s Report (see also p. 25, *ante*) has also some important points in common with that believed to have been used by Reis at the Hochstift. Neither of the specific forms described by Inspector von Legat are now known to be extant. Inquiries made in Frankfort and in Cassel have failed to find any trace of them. Neither at the local Naturalists’ Society, nor anywhere else in Cassel, did von Legat describe the invention. He met with a tragic end during the Bavarian War in 1866, in the battle near Aschaffenburg, having, according to some, been shot, or, according to others, fallen from his horse.]

[The next extract is from an article entitled ‘Telephonie,’ which appeared in a journal of science published at Leipzig, under the title ‘Aus der Natur.’ This article is essentially a paraphrase of Reis’s memoir read to the Physical Society in the preceding December (see p. 50), and contains the same illustrations, including a cut of the transmitter identical with [Fig. 9](#), p. 20.]

[6.] AUS DER NATUR. (Vol. xxi. 1862. July-October. pp. 470-474.)

“Until now, however, it was not possible to reproduce human speech with a distinctness sufficient for every person. The consonants are mostly tolerably distinctly reproduced, but the vowels not in an equal degree.”

[About this time there arose a Correspondence in the 'Deutsche Industrie Zeitung' ('German Journal of Industry') concerning the telephone. In No. xvi. p. 184 (1863), a correspondent who signs himself "K" asks whether the account of the telephone is true? In No. xviii. p. 208, there is given a brief answer; and No. xxii. contains, on p. 239, an extract from Legat's Report, on Reis's Telephone (see p. 70 of this work), together with an editorial remark to the effect that he had received a letter from Herr J. F. Quilling, of Frankfort-on-the-Main, who gives the information that in the transmission of singing in the telephone, the singer could be recognized by his voice.]

[7.][EXTRACT FROM THE ANNUAL REPORT OF THE PHYSICAL SOCIETY OF FRANKFORT-ON-THE-MAIN (1863).]

...; "and on the 4th of July, 1863, by Mr. Philipp Reis, teacher, of Friedrichsdorf, *On the Transmission of Tones to any desired Distance, by the help of Electricity, with the production of an Improved Telephone, and Exhibition of Experiments therewith.*"

[This was Reis's second occasion of bringing his Telephone before the Physical Society. The instrument had now-assumed the "square-box" pattern described at p. 27 of this work.]

[8.]LETTER OF PHILIPP REIS.

[In July 1863, Mr. W. Ladd, the well-known instrument-maker of London, bought one of Reis's Telephones of Messrs. J. W. Albert and Son of Frankfort. Philipp Reis wrote to Mr. Ladd the following letter of instructions, having heard that Mr. Ladd proposed to exhibit the instrument at the approaching meeting of the British Association. The autograph letter, written in English, is still preserved, and has been presented by Mr. Ladd to the Society of Telegraph Engineers and of Electricians of London.]

"Institut Garnier,
"Friedrichsdorf.

"DEAR SIR!

“I am very sorry not to have been in Francfort when you were there at Mr. Albert’s, by whom I have been informed that you have purchased one of my newly-invented instruments (Telephons). Though I will do all in my power to give you the most ample explanations on the subject, I am sure that personal communication would have been preferable; specially as I was told, that you will show the apparatus at your next scientific meeting and thus introduce the apparatus in your country.

“Tunes^[27] and sounds of any kind are only brought to our conception by the condensations and rarefactions of air or any other medium in which we may find ourselves. By every condensation the tympanum of our ear is pressed inwards, by every rarefaction it is pressed outward and thus the tympanum performs oscillations like a pendulum. The smaller or greater number of the oscillations made in a second gives us by help of the small bones in our ear and the auditory nerve the idea of a higher or lower tune.

“It was no hard labour, either to imagine that any other membrane besides that of our ear, could be brought to make similar oscillations, if spanned in a proper manner and if taken in good proportions, or to make use of these oscillations for the interruption of a galvanic current.

“However these were the principles which (*sic*) guided me in my invention. They were sufficient to induce me to try the reproduction of tunes [*i.e.*, tones—see footnote.—S. P. T.] at any distance. It would be long to relate all the fruitless attempts, I made, until I found out the proportions of the instrument and the necessary tension of the membrane. The apparatus you have bought, is now, what may be found most simple, and works without failing when arranged carefully in the following manner.

“The apparatus consists of two separated parts; one for the singing station A, and the other for the hearing station B.^[28]

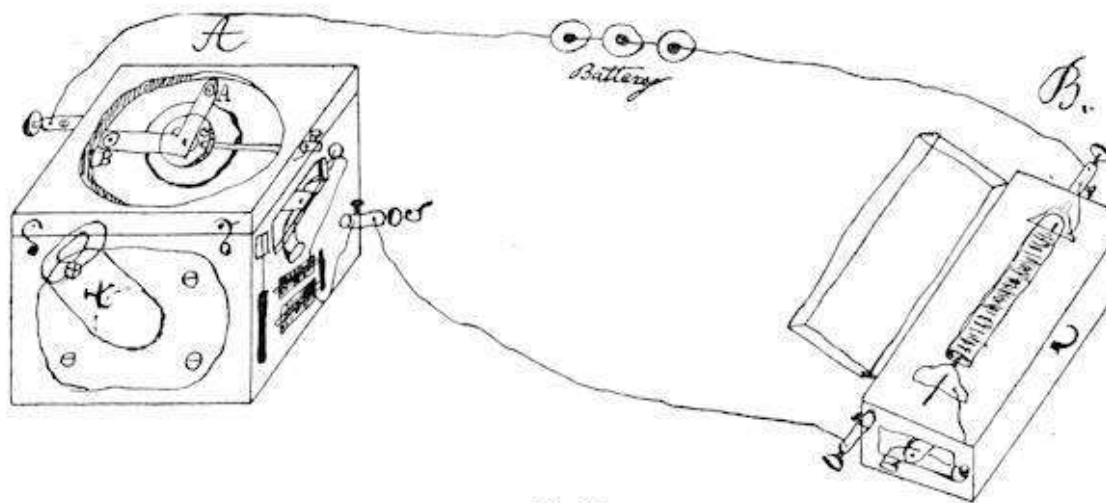

Fig 28.

“The apparatus A, a square box of wood, the cover of which shows the membrane (c) on the outside, under glass. In the middle of the latter is fixed a small platina plate to which a flattened copper wire is soldered on purpose to conduct the galvanic current. Within the cercle you will further remark two screws. One of them is terminated by a little pit in which you put a little drop of quicksilver; the other is pointed. The angle, which you find lying on the membrane, is to be placed according to the letters, with the little whole [hole] (a) on the point (a) the little platina foot (b) into the quicksilver screw, the other platina foot will then come on the platina plate in the middle of the membrane.

“The galvanic current coming from the battery (which I compose generally of three or four good elements) is introduced at the conducting screw near (b) wherefrom it proceeds to the quicksilver, the movable angle, the platina plate and the complementary telegraph to [29] the conducting screw (s). From here it goes through the conductor to the other station B and from there returns to the battery.

“The apparatus B, a sonorous box on the cover of which is placed the wire-spiral with the steel axis, wich will be magnetic when the current goes through the spiral. A second little box is fixed on the first one, and laid down on the steel axis to increase the intensity of the reproduced sounds. On the small side of the lower box you will find the correspondent part of the complementary telegraph.

“If a person sing at the station A, in the tube (x) the vibrations of air will pass into the box and move the membrane above; thereby the platina foot (c) of the movable angle will be lifted up and will thus open the stream at every condensation of air in the box. The stream will be re-established at every rarefaction. For this manner the steel axis at station B will be magnetic once for every full vibration; and as magnetism never enters nor leaves a metal without disturbing the equilibrium of the atoms, the steel-axis at station B must repeat the vibrations at station A and thus reproduce the sounds which caused them.

“Any^[30] sound will be reproduced, if strong enough to set the membrane in motion.

“The little telegraph, which you will find on the side of the apparatus is very usefull and agreeable for to give signals between both of the correspondents. At every opening of the stream and next following shutting the station A will hear a little clap produced by the attraction of the steel spring. Another little clap will be heard at station (B) in the wire-spiral. By multiplying the claps and producing them in different measures you will be able as well as I am to get understood by your correspondent.

“I am to end, Sir, and I hope, that what I said will be sufficient to have a first try; afterward you will get on quite alone.

“I am, Sir,

“Your most obedient Servant,

“PH. REIS.

“Friedrichsdorf, 13/7, 63.”

[9.] REIS'S PROSPECTUS.

[The following “Prospectus” of instructions was drawn up by Reis to accompany the Telephones which were sold by Herr Wilh. Albert of Frankfort. The author of this book is in possession of original copies, of which a number are extant. The “Prospectus” was also reprinted in its

entirety at page 241 of Professor Pisko's book 'Die neueren Apparate der Akustik,' published at Vienna in 1865.]

TELEPHON.

Each apparatus consists, as is seen from the above illustration, of two parts: the Telephone proper, A, and the Reproduction apparatus [Receiver], C. These two parts are placed at such a distance from each other, that singing, or the tones of a musical instrument, can be heard from one station to the other in no way except through the apparatus itself.

Both parts are connected with each other, and with the battery, B, like ordinary telegraphs. The battery must be capable of effecting the attraction of the armature of the electromagnet placed at the side of station A (3-4 six-inch Bunsen's elements suffice for several hundred feet distance).

The galvanic current goes then from B to the screw, *d*, thence through the copper strip to the little platinum plate at the middle of the membrane, then through the foot, *c*, of the angular piece to the screw, *b*, *in whose little concavity a drop of quicksilver is put*. From here the current then goes through the little telegraph apparatus, *e-f*, then to the key of station C, and through the spiral past *i* back to B.

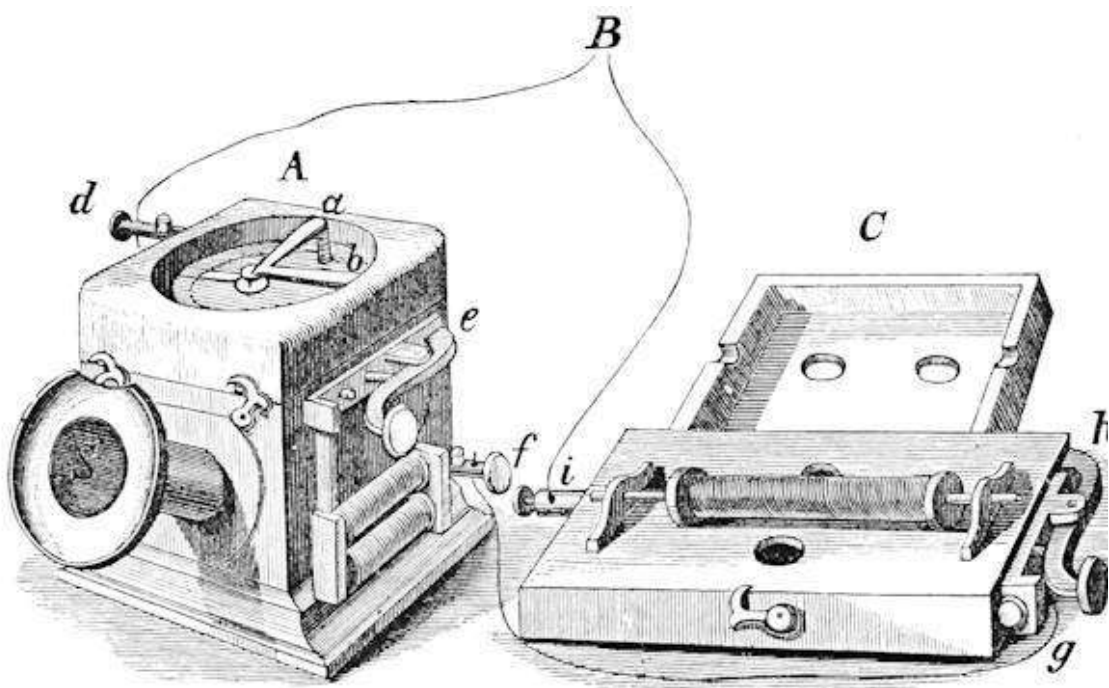

Fig. 29.

If now sufficiently strong tones are produced before the sound-aperture, S, the membrane and the angle-shaped little hammer lying upon it are set in

motion by the vibrations; the circuit will be once opened and again closed for each full vibration, and thereby there will be produced in the iron wire of the spiral at station C the same number of vibrations which there are perceived as a tone or combination of tones (chord). By imposing the little upper case (Oberkästchen) firmly upon the axis of the spiral the tones at C are greatly strengthened.

Besides the human voice (according to my experience) there also can be reproduced the tones of good organ-pipes from F—c' and those of a piano. For the latter purpose A is placed upon the sounding-board of the piano. (Of thirteen triads (Dreiklänge) a skilled experimenter could with all exactness recognise ten).

As regards the telegraph apparatus placed at the side, it is clearly unnecessary for the reproduction of tones, but it forms a very agreeable addition for convenient experimenting. By means of the same, it is possible to make oneself understood right well and certainly by the other party. This takes place somewhat in the following manner: After the apparatus has been completely arranged, one convinces oneself of the completeness of the connexion and the strength of the battery by opening and closing the circuit, whereby at A the stroke of the armature is heard, and at C a very distinct ticking.

By rapid alternate opening and closing at A it is asked at C whether one is ready for experimenting, whereupon C answers in the same manner.

Simple signals can by agreement be given from both stations by opening and closing the circuit one, two, three, or four times; for example:—

1 beat = Sing.

2 beats = Speak, &c.

I telegraph the words thus—that I number the letters of the alphabet and then transmit their numbers—

1 beat = *a*.

2 beats = *b*.

3 " = *c*.

4 " = *d*.

5 " = *e*, &c.

z would accordingly be designated by twenty-five beats.

This number of beats would, however, appear wasteful of time, and would be uncertain in counting, wherefore I employ for every five beats a

dactyl-beat (Dactylusschlag), and there results

— ◡ ◡ for e.

— ◡ ◡ and one beat for f, &c.

z, = — ◡ ◡, — ◡ ◡, — ◡ ◡, — ◡ ◡, — ◡ ◡,
which is more quickly and easily executed and easier to understand.

It is still better if the letters are represented by numbers which are in inverse proportion to the frequency of their occurrence.

PHIL. REIS,

Teacher at L. F. Garnier's Institute for boys.

Friedrichsdorf, near Homburg-by-the-Height,

August 1863.

[The foregoing "Prospectus" was accompanied by a further document printed as a postscript by Reis, at the top of which the figure of the instrument was repeated, and which ran as follows:—]

"P. P.,

"Since two years ago I succeeded in effecting the possibility of the reproduction of tones by the galvanic current, and in setting up a convenient apparatus therefor, the circumstance has found such a recognition from the most celebrated men of science, and so many calls to action have come to me, that I have since striven to improve my originally very incomplete apparatus, so that the experiments might thereby become accessible to others.

"I am now in the position to offer an apparatus which fulfils my expectations, and with which each physicist may succeed in repeating the interesting experiments concerning reproduction of tones at distant stations.

"I believe I shall fulfil the wish of many if I undertake to bring these improved instruments into the possession of the [physical] cabinets. Since the preparation of the same requires a complete

acquaintance with the leading principles and a tolerable experience in this matter, I have decided myself to prepare the most important parts of the same, and to leave the fashioning of the accessory parts, as also of the external adornments, to the mechanician.

“The distribution of the same I have made over to Herr J. Wilh. Albert, mechanician, in Frankfort-on-the-Main, and have placed him in the position to deliver these instruments in two qualities, differing only in external adornment, at the prices of 21 florins and 14 florins (12 thalers and 8 thalers current), inclusive of packing. Moreover, the instruments can also be obtained direct from me at the same prices, upon a cash remittance of the amount.

“Each apparatus will be tested by me before sending off, and will then be furnished with *my name, an order-number, and with the year of manufacture.*

“Friedrichsdorf, near Homburg-by-the-Height,
“in August 1863.

“PHIL. REIS,

“Teacher at L. F. Garnier’s Institute for Boys.”

[In September of the same year the telephone was shown by Prof. R Böttger at the meeting of the German Naturalists’ Association (Naturforscher), which met on that occasion at Stettin. Little or nothing is known of what took place at this exhibition, but Professor von Feilitzsch, of the neighbouring University of Greifswald, has informed the author of this work that the Telephone there shown was of the form figured in Reis’s Prospectus (p. 86), and that Reis claimed at that time to be able to transmit words by his instruments. In the same autumn the following notice appeared in Böttger’s ‘Notizblatt,’ and was copied thence into Dingler’s ‘Journal,’ and other scientific papers.]

[10.] ON THE IMPROVED TELEPHONE.

[Translated from the original notice which appeared in Böttger’s ‘Polytechnisches Notizblatt,’ 1863, No. 15, p. 225, and in Dingler’s ‘Polytechnisches Journal,’ 1863, vol. clxix. p. 399.]

At the meeting of the Physical Society of Frankfort-on-the-Main, on the 4th of July, a member of this Society, Herr Ph. Reis, of Friedrichsdorf, near Homburg-vor-der-Höhe, exhibited some of his improved Telephones (means for the reproduction of tones at any desired distance by the galvanic current). It is now two years since Herr Reis first gave publicity to his apparatus,^[31] and though even already at that time the performances of the same in their simple artless form were capable of exciting astonishment, yet they had then the great defect that experimenting with them was only possible to the inventor himself. The instruments exhibited in the above-named meeting scarcely reminded one of the earlier ones. Herr Reis has also striven to give them a form pleasing to the eye, so that they may now occupy a worthy place in every Physical Cabinet. These new apparatus may now also be handled by every one with facility, and work with great certainty. Melodies gently sung at a distance of about 300 feet were repeated by the instrument which was set up, much more distinctly than previously. The scale was reproduced especially sharply. The experimenters could even communicate words to one another, though certainly indeed only such as had often been heard by them. In order moreover that others who are less accustomed [to experimenting] may be able to understand one another through the apparatus, the inventor has placed on the side of the same a little arrangement,^[32] which according to his explanation is completely sufficient, the speed of communication of which is indeed not so great as that of modern Telegraphs, but which works quite certainly, and requires no special skill on the part of the one experimenting with it.

We would bring to the notice of gentlemen who are professional physicists that the inventor of these interesting pieces of apparatus now has them prepared for sale under his oversight (the important parts he makes himself), and the same can be procured from him direct, or through the mechanic, Mr. Wilhelm Albert, of Frankfort-on-the-Main, at 14 and at 21 florins, in two qualities, differing only in external adornment.

[A review, written by Dr. Röber of Berlin, of this and other articles relating to the Telephone appeared subsequently in the 'Fortschritte der Physik,' 1863, p. 96.]

[Another consequence of the publicity thus given to the Telephone was the appearance of an article on that instrument, under the title of "Der Musiktelegraph," in a popular illustrated weekly family paper, 'Die Gartenlaube,' published at Leipzig. This article, from the pen, it is believed, of Dr. Oppel of Frankfort, is made up chiefly of slightly altered extracts

from the previously quoted documents. The form of the instrument described is identical with that described in Reis's 'Prospectus,' and the figure given in the 'Gartenlaube,' No. 51, p. 809, is a reprint, apparently from the same wood-block of the figure which heads Reis's Prospectus, and which is reproduced on p. 86 of this work. The only passage of further interest is a brief sentence relating to the exhibition of the Telephone at the German Naturalists' Assembly at Stettin in 1863, and is as follows:—]

[11.]

“Now in order also to give to a still wider circle, especially to technologists (Fachmännern), the opportunity of witnessing with their own eyesight the efficiency of this apparatus,—lately, in fact essentially improved,—Professor Böttger of Frankfort-on-the-Main exhibited several experiments therewith at the meeting of the German Naturalists (Naturforscher) and Physicians recently held at Stettin, in the Section for Physics; which [experiments] would certainly have been crowned with still greater success if the place of meeting had been in a less noisy neighbourhood, and had been filled with a somewhat less numerous audience.”

[The next extract is a brief record from the Report of a scientific society meeting in Giessen, which during the Austro-Prussian war of 1866 had become disorganised, and which in 1867 published a condensed account of its proceedings for the preceding years. Amongst those proceedings was a lecture by the late Professor Buff, at which Reis's Telephone was shown, and at which Reis himself is believed to have been present.]

[12.] [EXTRACT FROM THE 'TWELFTH REPORT OF THE UPPER-
HESSIAN ASSOCIATION FOR NATURAL AND MEDICAL SCIENCE,'
(‘Oberhessische Gesellschaft für Natur und Heilkunde,’)
Giessen, February 1867.]

P. 155. Report on the doings and condition of the Association from the 1st of July, 1863, to the 1st of July, 1865, by Herr Gymnasiallehrer Dr. W. Diehl.

... On the 13th of February [1864], ‘On the Tones of the Magnet, with Application to the Telephone, with experiments,’ by Professor Buff.

EXHIBITION OF THE TELEPHONE TO THE NATURALISTS' ASSOCIATION OF GERMANY. (DEUTSCHE NATURFORSCHER VERSAMMLUNG.)

[By far the most important of all the public exhibitions given by Reis of his Telephone, was that which took place on the 21st of September, 1864, at Giessen, on the occasion of the meeting of the German Naturalists' Association (Versammlung Deutsche Naturforscher). Here were assembled all the leading scientific men of Germany, including the following distinguished names, many of whom are still living:—Prof. Buff (Giessen), Prof. Poggendorff (Berlin), Prof. Bohn (Frankfurt-a.-M., now of Aschaffenburg), Prof. Jolly (Munich), Dr. Geissler (Bonn), Prof. Weber (Göttingen), Prof. Plücker (Bonn), Prof. Quincke (Heidelberg), Prof. Dellmann (Kreuznach), Prof. Böttger (Frankfurt-a.-M. and Mainz), Prof. Kekule (Bonn), Prof. Gerlach (Erlangen), Dr. J. Frick (Carlsruhe), Dr. F. Kohlrausch (Württemberg), Prof. Reusch (Tübingen), Prof. J. Müller (Freiburg), Prof. Helmholtz (Heidelberg), Prof. Melde (Marburg), Prof. Kopp (Marburg), Prof. A. W. Hoffmann (London, now of Berlin), Mons. Hofmann (Paris, optician), Hofrath Dr. Stein (Frankfurt-a.-M.), Dr. W. Steeg (Homburg), Mons. Hartnack (Paris, and of Potsdam), Prof. G. Wiedemann (Basel, now of Leipzig), E. Albert (Frankfurt-a.-M., mechanic), Dr. Thudichum (London), W. Schultze (York, apothecary), Dr. J. Barnard Davis (Shelton), E. J. Chapman (London, chemist), Dr. L. Beck (London, chemist), Prof. Chas. J. Himes (U.S.A., chemist), E. W. Blake (New Haven, U.S.A., student), C. G. Wheeler (United States Consul in Nürnberg), and many others. Dr. C. Bohn (now of Aschaffenburg) was Secretary of the Association, and also Secretary of the Section of Physics. The meetings of this Section were held in the Laboratory of Professor Buff. Reis came over from Friedrichsdorf accompanied by his young brother-in-law, Philipp Schmidt. A preliminary trial on the morning of that day was not very successful, but at the afternoon sitting, when communications were made to the Section by Prof. Buff, by Reis himself, and by Prof. Poggendorff, the instrument was shown in action with great success. Reis expounded the story how he came to think of combining with the electric current interruptor a tympanum in imitation of that of the human ear, narrating his researches in an unassuming manner that won his audience completely to him; and the performance of the instrument was received with great applause. Various professors essayed to experiment with the instrument, with varying degrees of success according to whether their voices suited the instrument or not. Amongst these were Prof. Böttger and Prof. Quincke of

Heidelberg, whose account of the occasion is to be found on p. 112. Dr. Bohn, the Secretary of the Section, wrote for the 'Journal' (Tagesblatt), issued daily, the following notice.]

[13.] EXTRACT FROM THE REPORT OF THE GERMAN NATURALISTS' SOCIETY, HELD AT GIESSEN (1864).

"Afternoon sitting on 21st September, 1864.

"Prof. Buff speaks about the tones of iron and steel rods when magnetised, and exhibits the corresponding experiments.

"Dr. Reis demonstrates his Telephone, gives thereupon an explanation and the history of this instrument.

"Prof. Poggendorff produces tones in a metal cylinder, the slit up edges of which touch one another firmly, and which is placed loosely round an induction-bobbin through which there goes an interrupted current."

[This occasion was the crowning point of Philipp Reis's career, and might have proved of even greater importance but for two causes: the inventor's precarious health, and the indifference with which the commercial world of Germany viewed this great invention. Where the keen insight of Reis contemplated the vast possibilities opened out by the invention of a new mode of inter-communication, others saw only an ingenious philosophical toy, or at best a pleasing illustration of certain known principles of acoustic and electric science. And in spite of the momentary enthusiasm which the exhibition of the Telephone had evoked, the interest in it dwindled away. A few of the public journals of that date, noticed the invention in eulogistic terms and spoke of the prospect it afforded of communication between distant friends and of simultaneous concerts being given in different towns, all transmitted telephonically from one orchestra. But the invention came too early. The public mind was not yet prepared to take it up, and the enthusiasm died away. Still in a few of the more important books on Physics, Acoustics, and Electricity, the matter continued to receive attention. In the well-known Müller-Pouillet's 'Textbook of Physics' (Lehrbuch der Physik) edited by Professor J. Müller; in the 'Technical Physics' of Hessler, of Vienna, edited by Professor Pisko; in Pisko's 'Recent Apparatus of Acoustics,' and particularly in Kuhn's admirable 'Handbook of Applied Electricity,' the Telephone was accepted as a definite conquest of science, and was described and figured. From the

works named we transcribe the extracts which follow, and which sufficiently explain themselves.]

[14.] EXTRACT FROM MÜLLER-POUILLET'S 'TEXTBOOK OF PHYSICS AND METEOROLOGY' (LEHRBUCH DER PHYSIK UND METEOROLOGIE).

[Published at Brunswick, Sixth ed., 1863, vol. ii. page 352, fig. 325; and Seventh ed., 1868, vol. ii. pages 386-388, figs. 348-350. The following translation is from the latter edition.]

"This tone ... has Reis used for the construction of his Telephone.

"Figure 348^[33] exhibits Reis's interrupting apparatus. In the lid of a hollow cube of wood A, a circular opening is made, which is closed by an elastic membrane (pig's lesser intestine) strained over it. Upon the centre of this membrane is glued a little plate of platinum, which stands in conductive communication with the clamping-screw *a* by means of a quite thin little strip of metal *f* (distinctly visible in Fig. 349) [Fig. 31].

"Upon the middle of the little platinum plate, rests a short little platinum pencil, which is fastened at *g* to the under-side of the strip of tin-plate *h g i*, one end of which, *h*, rests upon the little metal pillar *l*, while a little platinum spike fastened upon its under-side at *i*, dips into the hollow of the little metal pillar *k*, containing some quicksilver. The clamping-screw *b*, is put into conductive communication with the little metal pillar *k*.

"From one pole of the battery there goes a conducting-wire to the clamping-screw *a* of the interrupting apparatus Fig. 348 [Fig. 30], from the other pole of the same there goes a wire to the clamping-screw *d* of the reproducing apparatus, Fig. 350 [Fig. 32], which is to be presently described. The clamping-screw *c*, of this apparatus, is connected by a wire with *b*, Fig. 348 [Fig. 30]. The clamping-screws *c* and *d* are connected with the ends of the wire of the small magnetising spiral M, Fig. 350 [Fig. 32]; with the connexion described above, the current of the current-generator (battery) goes, therefore, through the spiral M.

"As soon now as the sound-waves of an adequately powerful tone enter through the mouth-piece S into the hollow cube A, the elastic membrane which closes this at the top is set into vibrations. Each wave of condensation on entering lifts the little platinum plate together with the little spike which sits upon it; but if the membrane swings downwards, the tin-

piece $h g i$, with the little spike at i , cannot follow it quick enough; there therefore occurs here, at each vibration of the membrane, an interruption of the current which lets itself be recognised by a little spark appearing at the place of interruption.

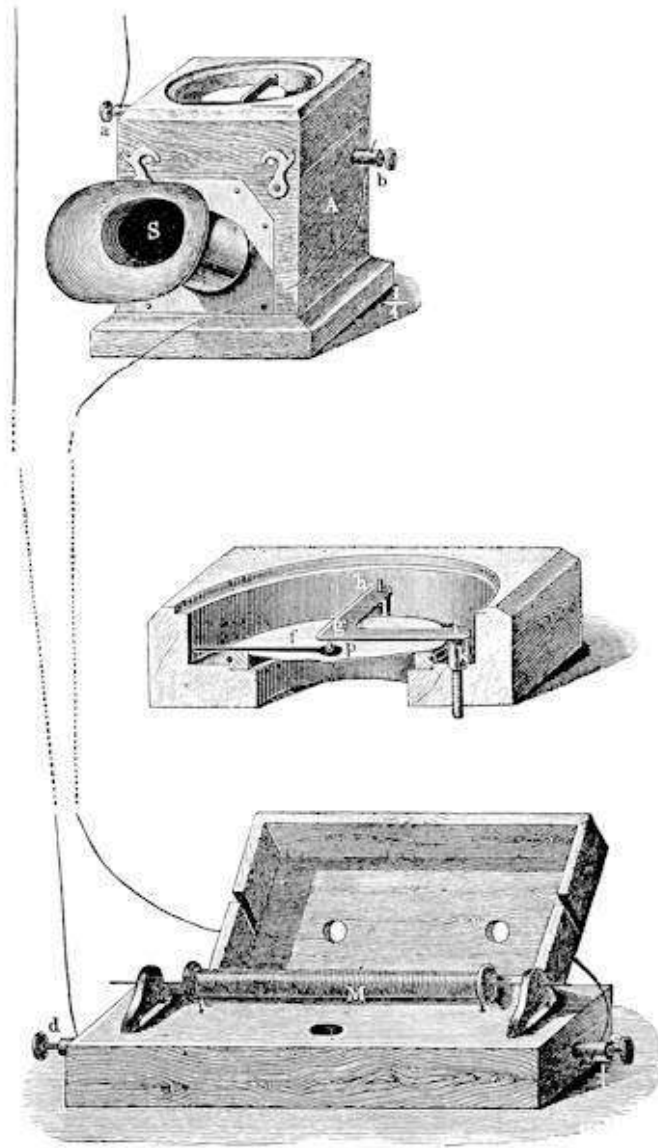

**Fig. 30. (top) Fig. 31. (middle) Fig. 32.
(bottom)**

“Now in the spiral M is stuck a knitting-needle, which, as the figure shows, is fastened into a sounding-board. A lid provided with second sounding-board may be clapped over the spiral, and the tone be thereby greatly strengthened.

“If now, tones are produced before the mouth-piece S , whilst one sings into the same or whilst one blows organ-pipes, one at once hears at the reproducing apparatus a peculiar creaking noise which is independent of the pitch of the tones produced at the interrupting apparatus, *but, beside this,*

those tones are themselves reproduced by the steel wire distinctly perceptibly, and indeed Reis found that this is the case for all tones between F and f”.

“In Reis’s experiments the interrupting apparatus was 300 feet distant from the spiral, and was indeed set up in another house with closed doors. But since the length of the conducting wire can be extended just as far as in direct telegraphy, Reis gave to his apparatus the name *Telephone* (Jahresbericht des physikalischen Vereins zu Frankfurt-a.-M. für 1860/61).”

[15.] EXTRACT FROM PISKO’S ‘DIE NEUEREN APPARATE DER
AKUSTIK.’

[This book, ‘The more recent Apparatus of Acoustics,’ by Dr. Francis Joseph Pisko, Professor of Physics in the Gewerbeschule in Vienna, was published at Vienna in 1865. At that time the novelties in acoustics were König’s apparatus for the graphic study of sounds, König’s manometric flames, Schaffgotsch’s singing flames, Helmholtz’s ‘Researches on the Quality of Sounds,’ Duhamel’s Vibrograph, Scott and König’s Phonautograph, and Reis’s Telephone. The account given of the latter is more detailed in some respects than any other published at the time.]

Page 94.—PRINCIPLE OF THE “TELEPHON” OF REIS.

51. (*a.*) Allied to the Membrane Phonautograph is the “Telephon” of Reis^[34] (Fig. 33). Upon the little membrane, *m m*, in the middle, is fastened with adhesive wax the round end *s* of a light strip of platinum, *n s*, so that the platinum strip can join in with all the vibrations of the membrane. Very near to the central end, *s*, of the little platinum strip, *n s*, a platinum spike stands, in such a way that it is brought into contact, by the vibrations of the membrane, with the platinum strip that vibrates with the latter. Suppose now that the outer end, *n*, of the platinum strip and the platinum spike are connected with the poles of a galvanic battery, then, by the vibration of the membrane the galvanic current will, according to the phase of the vibration, be alternately established and interrupted. Inserted in this circuit, an electro-magnetic bell, or an electro-magnetic telegraph, will give signals to great distances that somebody is speaking,^[35] though, obviously, it cannot inform *what* is being spoken.

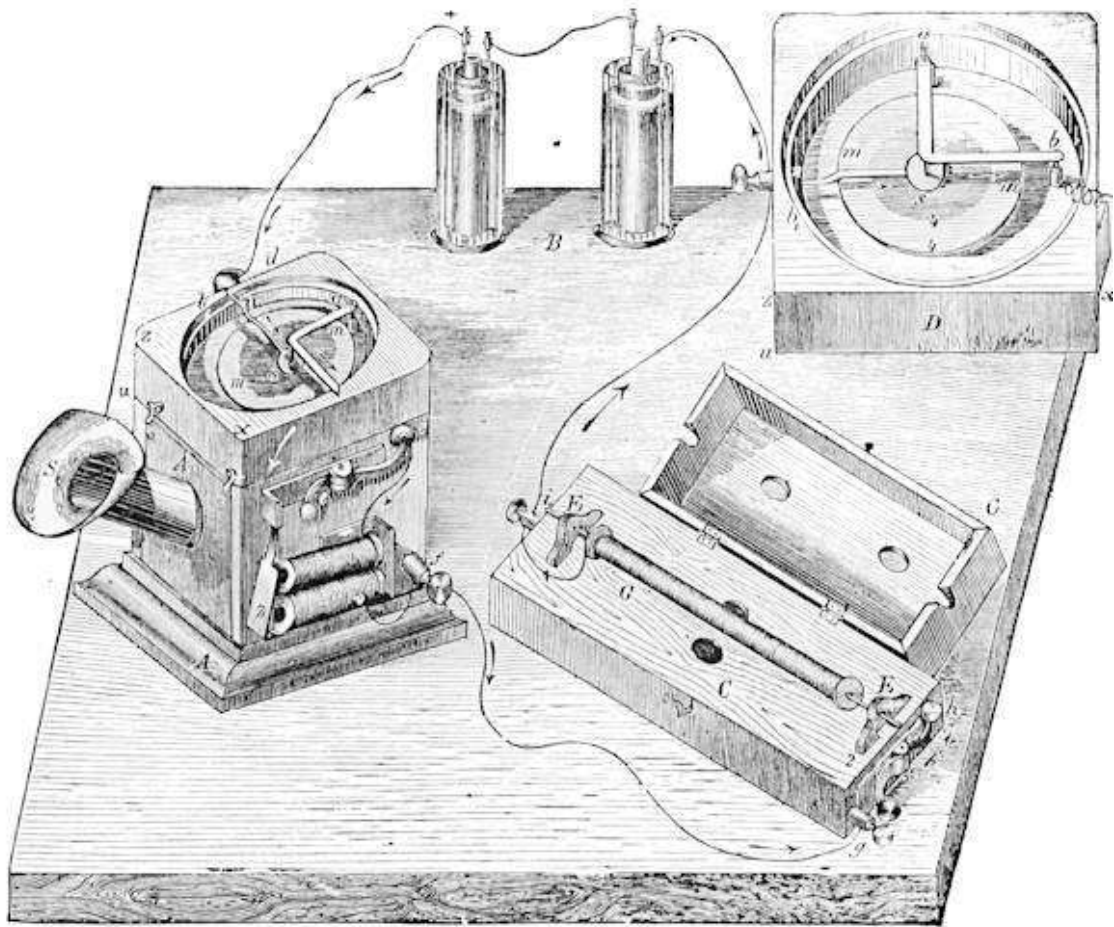

Fig. 33.

(b.) As is known, an iron wire around which flow rapidly-interrupted powerful galvanic currents, is thereby thrown into tones which, according to circumstances, may be longitudinal or transverse or both together. Such an iron wire, lying in a multiplying wire-coil, G, Reis inserted at the second [receiving] station, C. The wire emitted sounds when the membrane was set into vibrations by singing or speaking (at S, [Fig. 33](#)) into the hollow cubical piece A. In the investigations made by me with the telephone, the rod (of iron) never altered the pitch of its tone with the most different kinds of tones and clangs, and always gave only the rhythm of the words sung or spoken into the piece A (the transmitter) at S. Usually the air of the song that was sung could be recognised by its rhythm.^[36] The special researches on these points follow in paragraph 53. However, it is so far clear that there is still plenty of time yet before we have the *simultaneous concerts*, and the transmission of singing to different towns, as the daily newspapers have sanguinely expected. The apparatus of Reis is certainly a “Telephone” but not a “Phonic Telegraph.” The single means of transmission for song and speech—and that only for moderate distances—remains the old familiar speaking-tube. Nevertheless, the experiment of Reis must ever be reckoned

amongst the most beautiful and interesting of school-experiments. And since the means for this are so simple, the apparatus of Reis will certainly find a speedy entrance into educational establishments that are only moderately endowed. It is easily proved that the tones of the wire in the telephone do not arise from acoustic conduction, for by cutting out the coil from the circuit the tones immediately cease.

1. The Telephone of Reis originally consisted of a cube of wood with a conical boring. The smaller opening was strained over with a membrane. A knitting-needle which served for a sounding wire projected about 2 inches on each side of the multiplying coil, and lay upon the two bridges of a sounding-box. The surrounding helix consisted of six layers of thin wire. [Fig. 33](#) shows the Telephone as it is constructed at the present time by the mechanic, Albert, in Frankfort, and by the mechanic, Hauck, in Vienna, according to the directions of the inventor.

[52.] Details about the Telephone.

(a.) The same ([Fig. 33](#)) consists in its essentials:

1. Of a transmitter, *A*;
2. Of a receiver, *C*;
3. Of a galvanic battery, *B*, and lastly,
4. Of the conducting wires that connect them.

(b.) The transmitter, *A*, is essentially a parallelepipedal body of wood. The upper part, *u x*, of it is cut out of one piece [of wood] with square cross-section, the side, *x x*, of which measures 9 centimetres, and its height, *u x*, 2·8 centimetres.

This part is moveable upon a hinge on the lower little box, *A A*. If the cover, *x u*, is laid back, one sees that a small circle of 3·9 centimetres diameter has been cut out in the same. Into this hole passes a brass collar with a flange 8 millimetres broad, which is furnished at one side with a groove like a pulley. Over the collar there is stretched the membrane, *m m*, by means of a silk thread lying in the shoulder of the same. This circular

membrane is surrounded by a wider circular aperture, b , $b = 8.5$ centimetres. A shovel-shaped little strip of platinum, n , lies (over it) leading to the brass binding-screw, d , with the circular part, s , falling upon the centre of the membrane.

By means of some sealing-wax this circular part is fastened to the membrane, and thereby compelled to take part in the vibrations of the same. The further transmission of the galvanic current from the centre takes place by means of a platinum or steel point resting in a cup of mercury, which is extended in a screw, which transmits the current farther. The point a serves as a support for the angular hook, $a s b$, which in general is supported like a tripod, in order that the point of contact, s , may remain as constant as possible. The hook, $a s b$, is simply struck with a hole at a upon a projecting point, and lies upon a broader under part. From b the galvanic circuit proceeds by means of an overspun wire to the brass key e (A, [Fig. 33](#)), and from there farther in the direction represented by the arrow.

The lower part A A of the transmitter is put together of thin wood and forms a parallelepiped, whose height = 6.8 cm., and whose width = 7.7 cm. An inclined mouthpiece of tin with funnel-shaped opening serves to receive the tones. The longer side of this mouthpiece measures 6.7 cm., the shorter 4.7 cm.; the longer diameter of the widening measures 7.15 cm., the shorter diameter 7.5 cm., and finally the diameter of the narrow tube 3.9 cm.

It is clear that, if necessary, the platinum strip can be replaced by a strip of thin sheet-brass, the platinum or steel points by iron. Only in this case the points of contact must be oftener cleaned to a metallic polish.

(c.) The receiver (Zeichengeber) C is in general a double resonant box, whose upper part, "the cover," is moveable upon two hinges, and can be laid back. The length of this cover is 16.4 cm., its width 9.5 cm., and its height 3.2 cm. The length of the lower box measures 22.9 cm., its width 9.6 cm., and its height 2.5 cm. The under part of the resonant box bears two wooden bridges, which stand about 7.4 cm. from each other, and which serves as supports for the 21.5 cm. long, and 0.9 cm. thick iron needle destined for reproducing the tones. The length of spiral wound over the needle, and designed for making an electro-magnet of the same, is 15 cm. The wooden covers of both parts, scraped as thin as possible, and the greatest breadth of the circular holes shown in the figure, measures 13 mm.

(d.) For a battery one can successfully use a small Smee's consisting of four elements, or two larger Bunsen's cells.

The conductor must be at least sufficiently long that one cannot perceive the tones that are produced. For correspondence between the two stations the inventor has employed the electro-magnetic telegraph arrangement, *e v g h*, seen in the mechanism, and easily understood. An agreement in reference to corresponding signs can be easily arranged, and the simplest way is to accept the signals arranged by the inventor. (See 'Prospectus.')

The receiver C gives, when the key *e* is pressed, the corresponding telegraphic signals by means of tones in the rod E E, while at the transmitter, A, the electro-magnet *v* gives the signals by means of the springy armature *z*.

[53.] Experiments with the Telephone.

(a.) As soon as one brings the mouth to the funnel S and sings, the membrane of the transmitter, A, vibrates in a corresponding manner, and the iron rod, E E, at the second station begins to give forth a tone. Every time a spark is seen at the first station *s*, the rod at the other station certainly gives forth a tone. The same is true when one hears the peculiarly snarling tone which arises from the stroke of the vibrating platinum strip against the spike of angular hook resting upon it.

The appearance of these sparks or of the peculiar snarling at the transmitter A gives the sign to the observers at the station A that the rod in C is giving a tone. Tones and melodies which were sung into the sound aperture, and especially sounds in which the teeth and bones of the head also vibrated (so-called humming tones), always evoked a tone in the rod or needle E E, and indeed, as already mentioned (§ 51), without change in the pitch, but only with the reproduction of the rhythm of the respective song or words.

The pitch of the tone excited at C in the rod E E was in the apparatus at my disposal *h*; its strength not very great and its clang snarly, similar to that of a lightly sounding reed-whistle, somewhat like that of a child's wooden trumpet. The cuticle lying about the heart of the smaller and even the larger mammals (from calves, &c.) makes the best membranes. Goldbeater's-skins reproduce only the deeper tones. The cover of the sounding-box appeared in my apparatus superfluous, and indeed the tone was somewhat stronger without the cover.

1. In experiments with the telephone, one must look closely as to whether the ends of the platinum strip is still fastened to the membrane, and one must, if necessary, press upon the membrane. If the strip will no longer stick, heat a knife-blade, touch a small piece of sealing wax with it, and carry thus the melted sealing-wax to the under side of the round end of the platinum-strip, *n s*. Then press it immediately on the membrane, *m m*.

Ph. Reis showed his apparatus in very primitive form for the first time in October, 1861, to the Physical Society at Frankfort-on-the-Main; on July 4th, 1863, before the same society, he showed the form represented in [Fig. 33](#). This time he experimented upon a distance of 300 feet. Professor Boettger brought the apparatus before the Naturforscher-Versammlung at Stettin (1863) in the section for Physics.

[16.] HESSLER'S 'TEXT-BOOK OF TECHNICAL PHYSICS,' vol. i. p. 648.

[Next in chronological order comes a notice of the Telephone in Hessler's 'Lehrbuch der technischen Physik,' edited by Prof. Pisko, and published at Vienna in 1866. The brief account given in this work adds nothing to the accounts previously given, and is evidently written by some person ignorant of Reis's own work, for beside omitting all mention of the transmission of speech by the instrument, or of its being constructed upon the model of the human ear, the writer appears not even to know how to spell Reis's name, ^[37] and speaks of him as "Reuss."]

[17.] KUHN'S 'HANDBOOK OF APPLIED ELECTRICITY,'

('Handbuch der Angewandten Elektrizitätslehre,' von Carl Kuhn), being vol. xx. of Karsten's 'Universal Encyclopædia of Physics' (Karsten's 'Allgemeine Encyclopædie der Physik').

[Karsten's 'Encyclopædia of Physics,' which has been for many years a standard work of reference, both in Germany and in this country, consists of a number of volumes, each of which is a complete treatise, written by the very highest authorities in Germany. Thus Helmholtz contributed the volume on Physiological Optics, Lamont that on Terrestrial Magnetism,

whilst the names of Dr. Brix, Professor von Feilitzsch, and others, are included amongst the authors. Carl Kuhn, who wrote vol. xx., was Professor in the Royal Lyceum of Munich, and member of the Munich Academy. Kuhn's volume on 'Applied Electricity,' published in 1866, is to be found on the shelves of almost every library of any pretensions in Great Britain. The account given therein of Reis's Telephone is interesting, because it describes two forms, both of transmitter and of receiver. In fact the descriptions and figures are taken almost directly from von Legat's Report (p. 70), and from Reis's Prospectus (p. 87). The extract translated below includes all the matter that is of importance.]

P. 1017. The researches established by Reis on the 26th of October, 1861, in Frankfurt^[38] have already shown that if the current interruptions follow one another almost continuously and very rapidly, in a spiral arranged with a thin iron core, the iron wire can be set into longitudinal vibrations, whereby therefore the same is constrained to reproduce tones of different pitch.

[Here follows a reference to Petrina's Electric Harmonica.]

From the communications made known by Legat, it follows that "the ideas concerning the reproduction of tones by means of electro-galvanism which were put forward some time since by Philipp Reis of Friedrichsdorf, before the Physical Society, and the meeting of the Free German Institute in Frankfort-on-the-Main," relate to similar arrangements. "What has hitherto been attained in the realisation of this project," Legat announces in his report, and we extract therefrom only that part which gives an explanation of the disposition of the telegraphic apparatus, with which it is said to be possible to produce the vibrations and the excitement of tones in any desired manner, and by which the employment of electro-galvanism is said to make it possible "to call into life at any given distance vibrations similar to the vibrations that have been produced, and in this way to reproduce at any place the tones that have been originated at another place."

This apparatus consists of the tone-indicator (transmetteur) and the tone-receiver (récepteur). The tone-indicator ([Fig. 34](#), p. 109) consists of a conical tube, *a b*, having a length of about 15 cm., a front aperture of about 10 cm., and a back aperture of about 4 cm., the choice of the material and the greater length of which is said to be indifferent, while a greater width is said to be injurious; the surface of the inner wall should be as smooth as possible. The narrow back aperture of the tube is closed by a membrane, *o*, of collodion, and upon the centre of the circular surface formed by this membrane rests the one end, *c*, of the lever, *c d*, the supporting-point of which, *e*, being held by a support, remains in connection with the metallic circuit. This lever, the arm, *c e*, of which must be considerably longer than *c d*, should be as light as possible, so that it can easily follow the movements of the membrane, because an uncertain following of the lever, *c d*, will produce impure tones at the receiving station. During the state of rest the contact, *d g*, is closed, and a weak spring, *n*, keeps the lever in this state of rest. Upon the metallic support, *f*, which is in connection with one pole of the battery, there is a spring, *g*, with a contact corresponding to the contact of the lever, *c d*, at *d*, the position of which is regulated by means of the screw, *h*. In order that the effect of the apparatus may not be weakened by the produced waves of air communicating themselves towards the back part, a disc “of about 50 (?) cm. diameter, which rests fixedly upon the exterior wall of the tube,” is to be placed above the tube, *a b*, at right angles with its longitudinal axis.

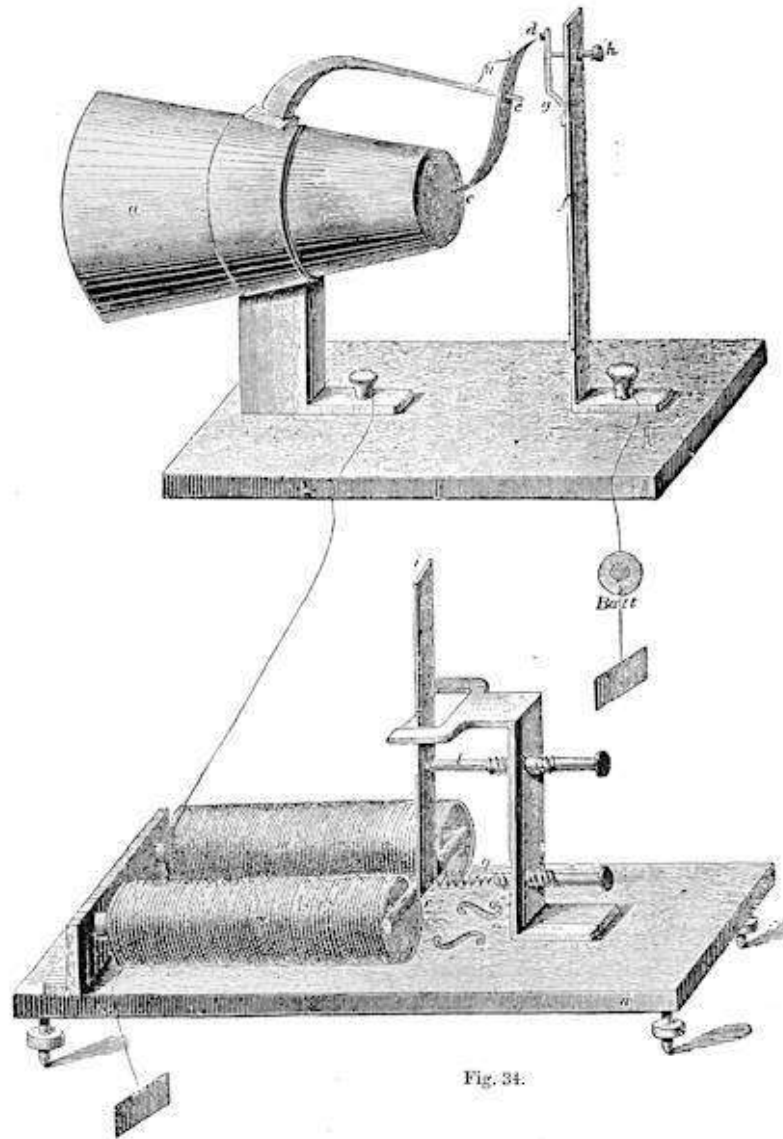

Fig. 34.

Fig. 34.

The tone-receiver consists of an electro-magnet, *m m*, which rests upon a resounding-board, *u w*, and the surrounding coils of which are connected with the metallic circuit and the earth. Opposite to the electro-magnet there stands an armature, which is connected with a lever, *i*, as long as possible but light and broad, and which lever together with the armature, is fastened like a pendulum to the support *k*; its movements are regulated by the screw *l* and the spring *q*. "In order to increase the effect of the apparatus, this tone-receiver may be placed in the one focus of an elliptically hollowed cavity of sufficient size, while the ear of the person who listens to the reproduced sounds ought to be placed at the second focus of the cavity." The action of the two apparatus, the general manner of connection of which may be seen from the illustrations—at the one station being the tone-indicator, at the other the tone-receiver—is the following:—By speaking into, singing, or

conducting the tones of an instrument into the tube, *a b*, there is produced in the tone-indicator ([Fig. 34](#)) in consequence of the condensation and rarefaction of the enclosed column of air, a motion of the membrane, *c*, corresponding to these changes. The lever, *c d*, follows the movements of the membrane, and opens or closes the circuit according as there occurs a condensation or rarefaction of the enclosed air. In consequence of these actions, the electro-magnet, *m m* ([Fig. 13](#)), is correspondingly demagnetised or magnetised, and the armature (and the armature-lever) belonging to it is set into vibrations similar to those of the membrane of the transmitting apparatus. By means of the lever, *i*, connected with the armature, the similar vibrations are transmitted to the surrounding air, and these sounds thus produced finally reach the ear of the listener (the sounding-board increasing the effect). As regards the effectiveness of this apparatus, the author remarks that while the similar number of the produced vibrations is reproduced by the receiver, their original strength has not yet been obtained by it. For this reason also small differences of vibration are difficult to hear, and during the practical experiments hitherto made, chords, melodies, &c., could be, it is true, transmitted with astonishing (?) fidelity, while single words in reading, speaking, &c., were less distinctly perceived.

[The rest of the article deals with the “square-box” transmitter described in Reis’s Prospectus, and adds nothing to the information already published.]

[This is the last of the contemporary documents bearing upon the performance of Reis’s instruments. From the prominent notice obtained at the time by the inventor, it is clear that his invention was even then accorded an honourable place amongst the acknowledged conquests of science. A critical examination of this body of evidence proves not only the substantial nature of Reis’s claim, but that the claim was openly recognised and allowed by the best authorities of the time. The thing was not done in a corner.]

CHAPTER V. TESTIMONY OF CONTEMPORARY WITNESSES.

1. Professor G. Quincke.
2. Professor C. Bohn.
3. Herr Léon Garnier.
4. Ernest Horkheimer, Esq.
5. Dr. R. Messel, F.C.S.
6. Herr Heinrich Holt.
7. Herr Heinrich F. Peter.
8. Mr. Stephen M. Yeates.
9. Dr. William Frazer.

PROFESSOR G. QUINCKE,
Professor of Physics in the University of Heidelberg.

[Professor Quincke, whose name is so well known in connection with his researches in molecular physics and in many problems of the highest interest to those acquainted with electrical science, was one of those present at the Naturforscher Versammlung held at Giessen in 1864, where Reis's Telephone was publicly exhibited by its inventor, see page 93, *ante*. His testimony, coming from so high authority, is therefore of exceptional value.]

“DEAR SIR,

“I was present at the Assembly of the German Naturalists' Association (Naturforscher Versammlung) held in the year 1864 in Giessen, when Mr. Philipp Reis, at that time teacher in the Garnier Institute at Friedrichsdorf, near Frankfort-on-the-Main, showed and explained to the assembly the Telephone which he had invented.

“I witnessed the performance of the instruments, and, with the assistance of the late Professor Böttger, heard them for myself.

“The apparatus used consisted of two parts—a transmitter and a receiver. The transmitter was a box, one side of which was furnished with a tube into which the speaking was to be done. At the top or the side of the box there was a circular opening, covered by a tympanum of membrane, upon which was fastened a piece of platinum. This piece of platinum was in communication with one pole of the galvanic battery. Over the membrane, resting upon the platinum, and in contact with it, was a piece of metal furnished with a platinum point, also in connection with one pole of the battery.

“The receiver consisted of a common knitting needle of steel, surrounded by a magnetising coil of insulated wire, which also formed a part of the circuit, the whole resting on a resonant box.

“I listened at the latter part of the apparatus, and heard distinctly both singing and talking. I distinctly remember having heard the words of the German poem, ‘Ach! du lieber Augustin, Alles ist hin!’” &c.

“The members of the Association were astonished and delighted, and heartily congratulated Mr. Reis upon the success of his researches in Telephony.

(Signed) “DR. G. QUINCKE, Professor.

“Heidelberg, 10th March, 1883.”

PROFESSOR C. BOHN.

[Professor C. Bohn, of Aschaffenburg, was formerly Secretary to the German “Naturforscher” Association, was also Secretary to the Physical Section of this Society (vide p. 93). In that capacity he had every opportunity of knowing what was going on in science; hence the following (translated) letter, addressed to the author of this book, is of peculiar value.]

“MOST ESTEEMED SIR,

“I willingly answer, as well as I am able to do so, the questions put by you. In order to explain that my recollections may not have all the sharpness

that might be wished, I make the following prefatory statement. I have, about 1863, held numerous conferences with Mr. Reis and with my deceased colleague, Professor H. Buff, of Giessen, and on these occasions have argued the question how it is that the transmission of thoughts to a distance by the sensation of the ear has a distinctly less value than transmission by that which is written....

“And now to your questions. I was not at Stettin in 1863. At the experiments at Giessen in the Naturforscher Assembly on 21st September, 1864, I was present; the short notice about them in the journal (‘Tagesblatt’) is from my pen. I was Secretary of the Assembly and of the Physical Section. I remember, however, almost absolutely nothing about *these* experiments. But I remember well that *previously*—therefore probably as early as 1863—having jointly made the experiments with Reis’s telephone in Buff’s house in Giessen.... I have *myself*, as speaker and as hearer, at least twice, in the presence of Reis, made the experiments.

“It was known to me (in 1863-64) that Reis intended to transmit words, and certainly spoken words as well as those sung. My interest in the matter was, however, a purely scientific one, not directed to the application as a means of profit.

“With great attention the sense of the words was understood. I have understood such myself, without knowing previously what would be the nature of the communication through the telephone. Words sung, especially well accentuated and peculiarly intoned, were somewhat better (or rather less incompletely) understood than those spoken in the ordinary manner. There was indeed a boy (son of Privy-Councillor Ihering, now of Göttingen, then of Giessen), who was known as specially accomplished as a speaker. He had a rather harsh North-German dialect, and after the first experiments hit on the right way to speak best, essential for understanding. I myself *did not* understand Professor Buff through the telephone. Whether the speaker could be recognized by his voice I doubt. We knew beforehand each time who speaks. Yet I remember that a girl could be distinguished from that boy by the voice.

“The ear was at times laid upon the box of the apparatus, also upon the table which supported the telephone. Then it was attempted to hear at a distance, with the ear in the air; in this respect, when singing, with good result. At times the lid was taken off, or the same was connected more or less tightly or loosely with the lower part. The result of these changes I can no longer give with distinctness....

“Should you desire further information, I am ready to give you it according to my best knowledge.

“Hochachtungsvoll ergebenster,
“DR. C. BOHN.

“Aschaffenburg,
“10th September, 1882.”

LÉON GARNIER.

[Herr Léon Garnier, Proprietor and Principal of the Garnier Institute at Friedrichsdorf, is the son of the late Burgomaster Garnier, who founded the establishment, and who, as previously narrated, encouraged Philipp Reis in his work and offered him the post of teacher of Natural Science. Herr Léon Garnier owns the small collection of instruments which Reis left behind, and which are preserved in the Physical Cabinet attached to the Institute, where also may be seen the gravitation machine—an ingenious combination of the principles of Atwood’s and Morin’s machines—and the automatic weather-recorder invented by Reis, both, however, very greatly out of repair. Herr Garnier has furnished to a friend the following particulars about Reis and his invention.]

“I knew Philipp Reis, now deceased, during his life-time.... About the year 1859, he was employed by my father, then proprietor and director of the Friedrichsdorf Garnier Institute, as teacher of mathematics and natural sciences. He employed his hours of leisure in experimenting for himself in a house occupied by himself, and in which he had established a physical laboratory with a view mainly of realizing an idea which he had conceived sometime before of transmitting the human voice over divers metallic conductors by means of a galvanic current.... I remember especially, that, standing at the end of the wire or conductor, Mr. Reis speaking through his instrument, I distinctly heard the words: ‘Guten Morgen, Herr Fischer’ (Good morning, Mr. Fischer); ‘Ich komme gleich’ (I am coming directly); ‘Passe auf!’ (Pay attention!); ‘Wie viel Uhr ist es?’ (What o’clock is it?);

‘Wie heisst du?’ (What’s your name?) We often spoke for an hour at a time. The distance was about 150 feet.

“LÉON GARNIER.”

ERNEST HORKHEIMER, ESQ.

“Manchester, *Dec. 2, 1882.*”

“Professor S. P. Thompson,

“DEAR SIR,

“In reply to your favour of 31st instant, I shall be very happy to give you all the information I can with respect to the telephonic experiments of my late friend and teacher Mr. Philipp Reis. I would express my gratification at finding that you are trying to put my old teacher’s claims on their just basis. I have always felt that in this race for telephonic fame, his claims have been very coolly put aside or ignored. That he did invent the Telephone there is not the remotest doubt. I was, I think, a great favourite of his; and at the time his assumption was that I was destined for a scientific career, either as a physicist or a chemist; and I believe that he said more to me about the telephone than to any one; and I assisted him in most of his experiments prior to the spring of 1862.

“Philipp Reis intended to transmit speech by his telephone—this was his chief aim; the transmitting of musical tones being only an after-thought, worked out for the convenience of public exhibition (which took place at the Physical Society at Frankfort-on-the-Main). I myself spent considerable time with him in transmitting words through the instruments. We never (in my time) got the length of transmitting complete sentences successfully, but certain words, such as ‘*Wer da?*’ ‘*gewiss,*’ ‘*warm,*’ ‘*kalt,*’ were undoubtedly transmitted without previous arrangement. I believe Reis made similar experiments with his brother-in-law.

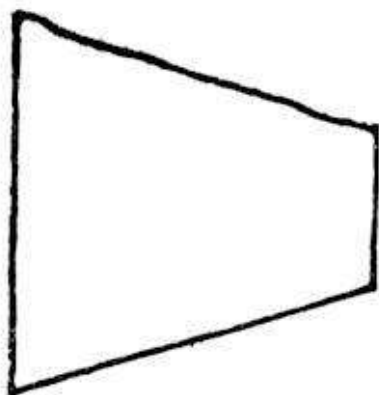

Fig. 35.

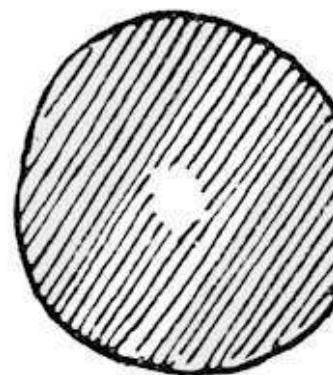

Fig. 36.

“I recollect the instrument in the shape of the human ear very well: it was Reis’s earliest form of transmitter. The transmitter underwent a great many changes, even during my time. The form you sketch ([Fig. 9](#), p. 20) was almost the oldest one, and was soon superseded by the funnel-shape ([Fig. 35](#)). The back was always closed by a tympanum of bladder, and many a hundred bladders were stretched, torn, and discarded during his experiments. I recollect him stating to me that he thought a very thin metal tympanum would eventually become the proper thing, and one was actually tried, coated over on one side with shellac, and on the other likewise, except at the point of contact ([Fig. 36](#)). I believe it was made of very thin brass, but at the time the experiments were not satisfactory. Talc was also tried, but without success, the platinum contacts being in all cases preserved.

“I remember very well indeed the receiver with a steel wire, surrounded by silk-covered copper wire. The first one was placed on an empty cigar-box, arranged thus:—

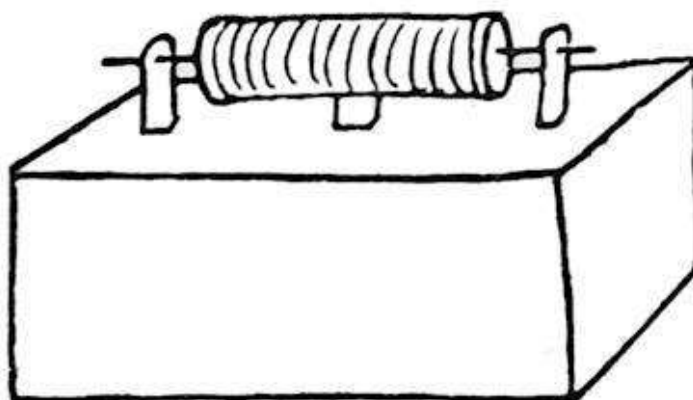

Fig. 37.

“The wire was a knitting-needle and the copper wire was spooled on a paper case.



“The spiral was supported by a little block of wood, so as to allow the knitting-needle not to touch it anywhere. Later on a smaller cigar-box was invented as a cover—thus; ([Fig. 38](#))—having two holes cut into it like the *f*-holes in a violin.

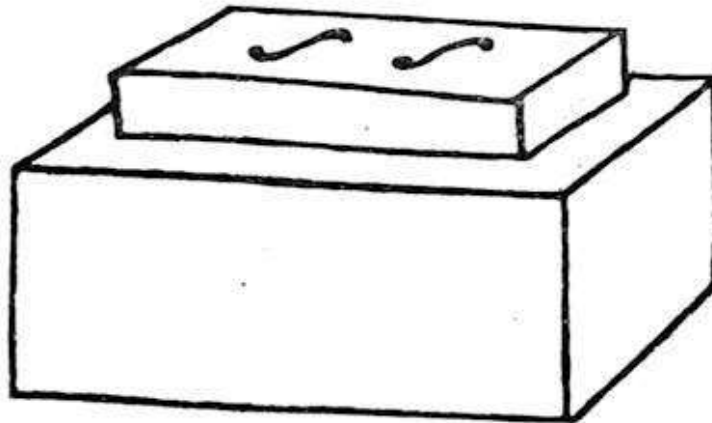

Fig. 38.

“The practice was to place the ear close to the receiver, more particularly so when the transmission of words was attempted.

“The spiral was, during the early experiments, placed on a violin—in fact, a violin which I now possess was sometimes used, as it was of a peculiar shape, which Reis thought would help the power of tone.

“I have already enumerated some of the words which were transmitted, but there were many more; on one occasion a song, known in this country as ‘The Young Recruit’ (*Wer will unter die Soldaten*) was transmitted, the air and *many* of the words being clearly intelligible.

“I do not recollect seeing the receiver shewn in the woodcut ([Fig. 21](#)), but Reis often said that he would make such a one, although the sketch he made for me then differed in some details from your woodcut. Reis intended to keep me fully informed of all he could achieve, but, immediately after leaving his tuition, I fell ill, and was laid up for a very long time. Shortly afterwards I left for England, and then he died, and I never saw him again. The electromagnet form was certainly strongly in his mind at the time we parted, and he drew many alternative suggestions on

paper, which have probably been destroyed; but the electromagnets in all of them were placed upright, sometimes attached to the top of a hollow box, and sometimes to the bottom of a box arranged thus (Figs. [39](#), [40](#)); but, to my recollection, they never got beyond the stage of drawings, whatever he may have done after he and I parted company.

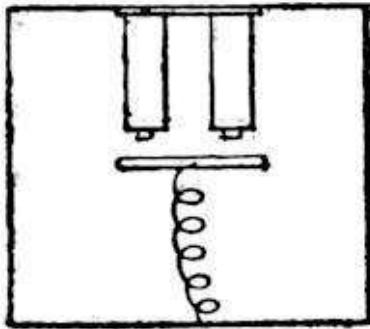

Fig. 39.

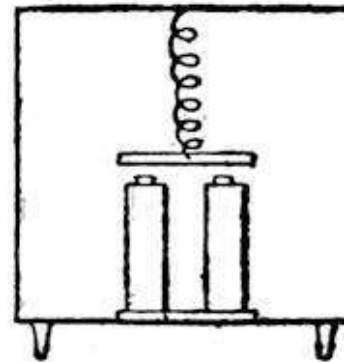

Fig. 40.

“In conclusion, I beg to send you herewith a photograph of Philipp Reis (see [Fig. 12](#), p. 23), holding in his hand the instrument I helped him to make, and which photograph he took of himself, exposing the camera by a pneumatic arrangement of his own, and which formed part of a little machine which he concocted for turning over the leaves of music-books.

“The instrument used by Reis at the Physical Society may have been the square block form: I believe that this cone-form was not quite completed then. At the Saalbau (Hochstift), however, I am *sure* the instrument shown in my photograph was employed; not with a tin cone, but a wooden one. I send you herewith a sketch of what I remember that instrument to have been. I am not absolutely certain whether in the instrument there was not an electromagnet introduced, but I think not. My recollection leads me to suppose that the electromagnet arrangement was added subsequently. Thinking it over again, I should, however, think that the instrument in the photo must have been one in which a bent lever was placed behind the tympanum, and that the rectangular patch seen above was a wooden casing to shelter the parts. There may be some confusion in my mind as to the position of this box, but I somehow think the rectangular patch is only part of a larger box which is not apparent in the photograph. I have no idea where the original instrument is now, but I should hardly think it could be in existence. Reis used to take some instruments to pieces to utilise parts in subsequent experiments, and I recollect how keen he used to be about the bits of platinum, which he always described as ‘ein sehr kostbares Metall.’

What always was a great puzzle was the attaching of the platinum plate to the membrane, which he did generally by sealing-wax, saying at the same time: 'Es ist nicht recht so, aber ich weiss nicht wie es anders gemacht werden kann!'

“Believe me, my dear Sir, yours truly,

“ERNEST HORKHEIMER.”

DR. RUDOLPH MESSEL.

[The following letter from Dr. Rudolph Messel, F.C.S., addressed to the author of this book, in reply to enquiries concerning Reis and his inventions, speaks for itself. Dr. Messel's letter differs from almost all the others here reprinted in having been specially written for the purpose of being inserted in this volume.—S. P. T.]

“36, Mark Lane, London, *30th April, 1883.*

“DEAR PROFESSOR THOMPSON,

“At last I find a moment to comply with your request. My knowledge of Philipp Reis dates from 1860, when I was a pupil at Professor Garnier's School at Friedrichsdorf, of which school Reis was one of the undermasters. Reis, naturally communicative, was very fond of talking to us boys about his scientific researches. And it was on the occasion of one of our daily walks together that he told me how, when an apprentice at Beyerbach's (colour-manufacturer), in Frankfurt-a.-M., he was one day amusing himself in watching the behaviour of a small magnetic compass. This compass he found, on being placed near to the base of various iron columns in the warehouse, was attracted. Disturbed by the entrance of one of the principals, who imagined that Reis ought to employ his time more profitably, he withdrew to a stage where he could pursue his experiments unobserved. Much to his surprise, he now found that the pole attracted by the base was repulsed at the top of the columns, which observation led him to examine other pieces of iron on the premises. He next built up a column

with all the weights in the warehouse, and having verified his previous observations, he communicated what he believed to be his first and great discovery either to Professor Böttger or to Dr. Oppel. Great was his disappointment to learn at this interview that he had unwittingly stumbled across a well-known physical fact: but his disappointment stimulated in him the desire to learn more of the marvellous laws and mysteries of nature. That Reis evoked a similar desire in those with whom he came in contact need not cause surprise, and thus it came about that Horkheimer, Küster, Schmidt, and myself, soon enjoyed the privilege of private instructions in physics, and of being permitted to witness his telephonic experiments amongst others. I was, however, very young, and am sorry that much that I then saw and heard has been forgotten, Reis insisted that his transmitter (which he called the ‘ear’) should be capable of performing the functions of that organ, and he never tired of drawing diagrams of the numerous curves of sounds to explain how necessary it was that the transmitter should follow these curves before perfect speaking could be attained, and which kind of curves the instrument so far could reproduce. Numerous experiments were made with transmitters, exaggerating or diminishing the various component parts of the ear. Wooden and metallic apparatus, rough and smooth, were constructed in order to find out what was essential, and what was not.

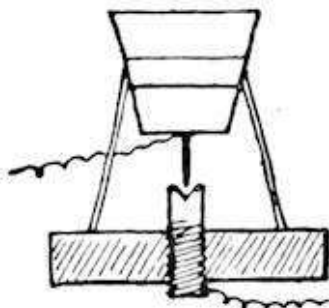

Fig. 41.

“One form of transmitter was at that time constructed which I miss amongst the various woodcuts you were good enough to send me, and one which Reis based great hopes upon. The instrument was very rough, however, consisting of a wooden bung of a beer-barrel (which I had hollowed out for an earlier telephone—it was not turned inside like others), and this was closed with a membrane. The favourite ‘Hämmerchen’ was replaced by a straight wire, fixed in the usual way with sealing-wax, and the apparatus stood within a sort of tripod, membrane downwards, the pin just touching the surface of a drop of mercury contained in a small cup forming one of the terminals of the circuit. The apparatus started off with splendid results, but may probably have been abandoned on account of its great uncertainty, thus sharing the fate of other of his earlier instruments. In my belief it is to these mechanical imperfections, due principally to the want of sufficient means at his command, that we must look to find the reason why Reis’s telephone did not come to an earlier fame. Thus Reis informed me that he intended to

exhibit it once at some scientific meeting at Cassel, but notwithstanding a perfect rehearsal it was impossible to show the working to the audience; the failure was attributed by Reis to atmospheric influence (stretching of the diaphragm), and he felt much grieved at having lost his chance. To make matters worse, the early transmitters had no adjusting screws, and the contact was only regulated by a piece of bent wire, and the 'hammer' was fixed to the membrane. Philipp Schmidt should recollect what I state, as many experiments were made when only he, Reis, and myself were present, he being at one and I at the other end of the apparatus. The wire was stretched from Reis's house, in the main road, through the yard to a hayloft, near the garden or field. We transmitted musical sounds (organ, &c.), singing popular songs ('Wer will unter die Soldaten,' 'Ich hatt' einen Kameraden,' &c.) and speaking, or, more correctly, reading. We had a book, and were to find out what part of the page the reader was just transmitting. We frequently used a sort of 'Exercier Reglement,' a soldiers' instruction book, or something of that sort. I have a distinct recollection of electromagnetic receivers being used, but not of their construction, except that the use of one of them was accompanied by a rattling and disturbing noise. The knitting-needle put in the *f* of a violin was, however, the more favoured receiver, but at this time, in Reis's mind, all seemed to hinge on the electromagnet, as it had before, and, I dare say, did again afterwards on the transmitter. I left Friedrichsdorf in '62, and rarely saw Reis after that, except a few times at Mechanicus Albert's (who made some of his apparatus), and at Professor Böttger's, to whom he introduced me. Reis attended Professor Böttger's lectures at the Physikalischer Verein, when in Frankfort, prior to his settling down at Friedrichsdorf; but I do not know that any particularly intimate relation existed between them. Dr. Poppe, director of the Gewerbeschule (Trade School), now deceased, on whose advice he chiefly relied, was then one of his more intimate friends, Professor Opper being occasionally consulted about more intricate mathematical problems. Of the 'meteorological recorder' invented by Reis I recollect but its existence, but nothing at all of a 'fall-machine' of his construction. The velocipede I only recollect, because he lent it to me for a masquerade. At his suggestion we altered it into a large musical-box, putting Herr Peter inside, who played on the clarinet when I turned a handle. Dr. Kellner states that its chief merit consisted in being able to go downhill, and that poor Reis came back (uphill) puffing away, dragging his velocipede behind him. Kellner no doubt could give valuable information on Reis's theory of electricity, his conviction that there was only one kind of

electricity, his acoustic researches, and those on radiation of electricity, his galvanoplastic experiments, &c., &c.

“In personal appearance Reis was not very refined, but he had a striking countenance and a very powerful look. Though occasionally very irritable, especially with dunces, he was always warm-hearted, and showed great kindness to those who cared to understand him. Reis’s views of the telephone may, of course, have changed after I knew him, and looking at his later instruments, one of which I possess, I cannot help thinking they did; at any rate, I do not see how, in these instruments, the current got interrupted at all, and the instruments must have acted like microphones, whether known or unknown to him. When listening to the instrument he frequently said to me, “You understand it is a ‘molekular Bewegung’ (molecular motion).”

“I am sorry that, owing to the lapse of time, I am unable to throw more light on Reis’s original labours in a field of physical science which promised so much for the future; but insufficient as are my recollections, they may not be without public interest, and at any rate I am glad of this opportunity of offering my humble tribute of regard and affection to the memory of my old teacher and friend.

“Yours truly,

“RUDOLPH MESSEL.”

HEINRICH HOLD.

[Herr Hold, formerly a colleague of Philipp Reis in the Garnier Institute at Friedrichsdorf, but now proprietor of a leather factory in the same place, was teacher of mathematics. He was in his younger days a fellow-student of Professor Tyndall at Halle, and was well acquainted with physical science in general. His intimate connection with Reis, and close knowledge of Reis’s work, enable him to confirm the testimony of others in many important points.]

To Professor S. P. THOMPSON in Bristol.

“ESTEEMED SIR,

“I have much pleasure in furnishing you with the following particulars concerning my late colleague Philipp Reis, the inventor of the Telephone. He was himself educated at the Garnier’s Institute in Friedrichsdorf where I was also teacher of mathematics. I knew him very well during his life-time. Among his numerous original researches, his invention of the telephone was the principal one. His idea was to reproduce the tones both of musical instruments and of the human voice by means of electricity, using a covered wire wound in a spiral round an iron core, the same being placed upon a resonant box. In this he succeeded, inasmuch as with an apparatus, which he showed to the Physikalischer Verein in Frankfurt-a.-M., in the year 1861, he reproduced music, singing, single words and short sentences; all of which were distinctly audible over a short distance from his dwelling-house through the yard to the barn. Every voice was not equally well adapted for speaking into the apparatus, neither could every ear understand the telephone language equally well. Words spoken slowly, and singing, both in a middle tone, were the most easy to reproduce. I helped Mr. Reis to make many of his experiments, and have spoken and sung into the telephone, the same being generally heard and understood. I have also heard and understood short sentences when I was standing at the end station. A brother-in-law of Mr. Reis, who is now paymaster in the Imperial Navy at Wilhelmshavn, generally conducted the speaking and singing in the telephone.

“HEINRICH HOLD.”

HEINRICH FRIEDRICH PETER.

[Herr Peter is still Music-teacher in the Garnier Institute, and has a vivid recollection of his former colleague Philipp Reis, and of the experiments with the telephone.]

“DEAR SIR,

“The following particulars concerning Reis’s Telephone I have several times narrated. I was teacher of music in Garnier’s Institute at the time

when Mr. Reis invented the telephone, in the year 1861. I was much interested in his experiments, and visited him daily, giving him help and making suggestions. His first idea was to imitate the construction of the human ear. He constructed a funnel-shaped instrument, the back of which was covered with a skin of isinglass, upon which was fastened a piece of platinum, against which rested a platinum point. As receiver of the electric current he used a common knitting-needle, surrounded by a coil of insulated green wire, which was at first merely laid on a table. At first the tones were very much interfered with by a buzzing noise. At my suggestion he placed the spiral upon my violin as a resonant-box; whereupon the tones were perfectly understood, though still accompanied by the buzzing noise. He continued experimenting, trying various kinds of membranes, and made continual improvements in the apparatus. I was present and assisted at the experiments at Frankfort-on-the-Main, on the 26th of October, 1861; and after the meeting broke-up, I saw the members of the Society as they came and congratulated Mr. Reis on the success of his experiments. I played upon the English horn, and Philipp Schmidt sang. The singing was heard much better than the playing. At an experiment which we made at Friedrichsdorf, in the presence of Hofrath Dr. Müller, Apothecary Müller, and Professor Dr. Schenk, formerly Director of Garnier's Institute, an incident occurred which will interest you. Singing was at first tried; and afterwards his brother-in-law, Philipp Schmidt, read long sentences from Spiess's 'Turnbuch' (Book of Gymnastics), which sentences Philipp Reis, who was listening, understood perfectly, and repeated to us. I said to him, 'Philipp, you know that whole book by heart;' and I was unwilling to believe that his experiment could be so successful unless he would repeat for me the sentences which I would give him. So I then went up into the room where stood the telephone, and purposely uttered some nonsensical sentences, for instance: 'Die Sonne ist von Kupfer' (The sun is made of copper), which Reis understood as, 'Die Sonne ist von Zucker' (The sun is made of sugar); 'Das Pferd frisst keinen Gurkensalat' (The horse eats no cucumber-salad); which Reis understood as 'Das Pferd frisst....' (The horse eats ...). This was the last of these experiments which we tried. Those who were present were very greatly astonished, and were convinced that Reis's invention had opened out a great future.

“H. F. PETER, Musiklehrer.”

STEPHEN MITCHELL YEATES, ESQ.

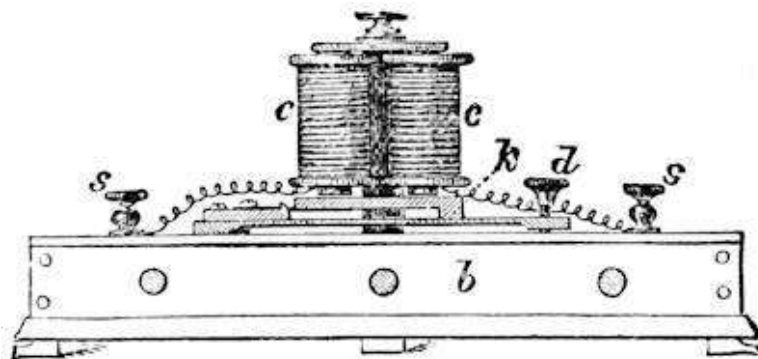

Fig. 42.

[Mr. Yeates is a well-known instrument-maker in the city of Dublin, and in 1865, purchased from Mr. W. Ladd, of London, a Reis's Telephone of the form shown in Reis's Prospectus ([Fig. 29](#)). Mr. Yeates, after a few experiments, rejected the knitting-kneedle receiver, and replaced it by the instrument shown in [Fig. 42](#), which consisted of an electromagnet mounted above a sound-box, having a vibrating armature furnished with an adjusting screw to regulate its distance from the poles of the electromagnet. This instrument worked, even when the armature was in absolute contact with both poles of the electromagnet, and as the magnet did not during the experiments lose its hold on the armature, it was clear that the effects were due to alterations in the intensity of the magnetism of the magnet. The apparatus was shewn at the November meeting of the Dublin Philosophical Society, when singing and words were transmitted. With a careful adjustment it was possible to distinguish all the quality of the note sung into the transmitter and to distinguish the difference between any two voices. The instruments were then sold to the late Rev. Mr. Kernan, who was then Professor of Physics in Clongowes Wood College. The following recent letter from Mr. Yeates corroborates the above facts.]

“2, Grafton Street, Dublin,

“*March 1st, 1883.*

“DEAR SIR,

“There are several residing at present in Dublin who were present at my telephonic experiments in 1865; three of them, namely, Dr. W. Frazer, Mr. A. M. Vereker, and Mr. E. C. Tuke, took an active part in the experiments, and remember all the circumstances connected with them. The voice of each was instantly recognised in the receiver; in fact, this point attracted special attention at the time.

“I had no knowledge at that time that Reis had used an electromagnetic receiver, nor did I know that Reis was the inventor of the instrument which I got from Mr. Ladd.

“The original instrument made by me is, I believe, still in the Museum at Clongowes Wood College. The President kindly lent it to me some time ago, and I returned it to him again after showing it to Professor Barrett. I have a cut of this receiver, which I will send to you if it will be of any use to you.

“Yours truly,

“S. M. YEATES.”

WILLIAM FRAZER, ESQ., M. D.,

“20, Harcourt Street, Dublin,

“*March 13, 1883.*

“DEAR SIR,

“I have a distinct recollection of the Telephone. We had a small private club meeting once each month for scientific purposes. On referring to my note-books, I find that there was a meeting on Thursday evening, October 5th, 1865. It was held in Nassau Street, at the residence Mr. Horatio Yeates, now in Australia, and brother of Mr. Stephen Yeates. The Telephone was upstairs, in the third story of the house, and the voice heard in the hall. Mr. Vereker, of the Bank of Ireland, Mr. John Rigby, of rifle celebrity, the two Mr. Yeates, and, I think, Mr. Tuke, were present with myself. There were some others, whom I cannot now recollect, but our club was small.

“Rigby sang ‘Patrick’s Day’ and ‘God save the Queen,’ and various questions were asked and answered. The separate words were most distinct, the singing less so; but there was no difficulty in recognising the individual who spoke by his voice.

“Being much interested in the subject, I got Mr. Yeates to allow the apparatus to be shewn at a *Conversazione* (Presbyterian Young Men’s) at the Rotunda on October 12, at 8 P.M. His assistant, Mr. Tuke, took charge of it that night. It was placed in a side room off the main round room of the buildings.

“I exhibited at the October 5th meeting of our club a specimen termed ‘Locust gum,’ probably derived from some *Robinia*, but really can tell you nothing more about it. There is merely a brief note of it in my private memoranda.

“Yours, dear Sir,
Believe me very truly,
“WILLIAM FRAZER,

“Fellow and Examiner, Royal College of Surgeons, Ireland, Member of
Council, Royal Irish Academy, &c.”

“Silvanus P. Thompson, Esq., University College, Bristol.”

APPENDIX I.

COMPARISON OF REIS'S TRANSMITTERS WITH RECENT INSTRUMENTS.

Any one who compares together the many different forms of Reis's Transmitters cannot fail to notice that amidst the great variety of form, two essential points are preserved throughout, the presence of which is fundamental. These two essentials are, firstly, the tympanum to collect the voice-waves, and, secondly, an electric mechanism, consisting of two or more parts in loose or imperfect contact with each other, and so arranged in combination with the tympanum that the motions of the latter should alter the degree of contact, and consequently interrupt, to a greater or less degree, the current of electricity flowing between the contact-pieces. It was of course familiar to all electricians, long before Reis, that a bad, or imperfect, or loose contact in a circuit offered a resistance and interrupted the flow of an electric current. In all ordinary telegraphic and electric apparatus great care was taken to avoid loose and imperfect contacts by using clamping-screws and solid connectors. But Reis, having made up his mind (see p. 77) that the action due to the magnetising current must vary in a manner corresponding with, and therefore proportional to, the vibrations of the voice, utilised this property of imperfect contacts which alter their resistance according to the degree of contact, by arranging his mechanism so as to apply the voice to vary the degree of contact. This was the essence of his transmitters. In other words, he applied the voice to control or moderate the strength of the current generated by a battery. His "interruptors" may therefore with propriety be called "electric current contact regulators;" and put into technical language, the essence of this part of his invention lay in the combination with a tympanum of electric current regulators working upon the principle of variable contact.

In another appendix is discussed the precise nature of that which occurs at a point of variable or imperfect contact, and which results in a corresponding change of electrical resistance when the degree of contact is varied. Suffice it to say here that it is impossible to vary the degree of contact between two bodies which are lightly pressing one against the other,

and through which an electric current is flowing, without altering the resistance offered to the current by this joint in the circuit. If the two surfaces are pressed together, so that there is a good contact, the current flows more freely, finding less resistance. If, on the other hand, by altering the pressure or the amount of surface exposed, we change the degree of contact and cause fewer atoms of one piece to touch those of the other piece, the current meets with greater obstruction and cannot flow with such strength as before: it is partially “interrupted,” to use the expressive term employed by Reis.

Now this operation of varying the degree of pressure in order to vary the resistance of the interrupter or contact regulator, was distinctly contemplated by Reis. We find his definite instructions, for example (see p. 75), for arranging the relative lengths of the two parts of the curved lever in one of his transmitters, so that the movement of one contact-piece may act on the other contact-piece with the greatest possible *force*; in other words, he shortened his lever at the working end, sacrificing its range of motion in order to get a greater range of pressure at the contact-point.

It has often been said, but incorrectly, that Reis intended his “interruptors” or contact regulators to make and break the electric circuit abruptly in the manner of a telegraphic key worked by hand. No doubt in the mouth of a professional telegraph operator the words “interrupting” the circuit, and “opening” and “closing” the circuit, do now-a-days receive this narrow technical meaning. But Reis was not a professional telegraph operator: he did not (see p. 87) even know the signals of the Morse code, and it is self-evident that he did not use the terms in any such restricted or unnatural sense as abrupt “make-and-break,” because he proposed at the outset to interrupt the current in a manner represented by the gradual rise and fall of a *curve*, stating emphatically in his very first memoir on telephony (p. 55), that to reproduce any tone or combination of tones all that was necessary was “to set up vibrations whose curves are like those” of the given tone or combination of tones. Moreover, in the construction of almost all his transmitters, even in the very first—the model of the human ear—he purposely introduced certain parts which could have no other effect than to prevent the occurrence of complete breaks in the continuity of the current. In fact, instead of using rigid supports for his interruptor, he mounted one or both of the contact-parts with springs, so that one should follow the movement of the other with a gentle pressure never amounting to absolute break, except perhaps in the accidental case of a too loud shout. By employing these following-springs, he introduced, in fact the element of

elasticity into his interruptor; and clearly he introduced it for the very purpose of avoiding abrupt breaking of the contact. In the first form Fig. 5, p. 16 (the “ear”), there was one spring; in the fourth form, Figs. 9 and 10, p. 21 (the “bored block”), there were two springs, one of steel, curved, and one, a straight but springy strip, of copper; in the eighth form (the “lever” form), Fig. 14, p. 25, there were two springs; in the ninth form, Fig. 15, p. 26, there was a springy strip of brass. In the final form, Figs. 17 and 18, p. 27 (the “square-box” pattern), there was, it is true, a springy strip of copper, but the light adjustment of contact was in this form obtained, not by a spring, but by the inertia of the upper contact-piece which by its own weight pressed gently upon the lower contact-piece. In every one of these forms, except the last, there was moreover an adjusting-screw to determine the exact degree of initial pressure between the contact surfaces. Doubtless the difficulty of adjusting this screw to give the exact degree of contact, enhanced as that difficulty was in consequence of the liability of the membraneous tympanum to become flaccid by the moisture of the breath, induced Reis to think that the later form of the apparatus in which this adjustment was no longer retained would be more easy to use, or, as he says in his Prospectus, more accessible to others. Yet undoubtedly the absence of the spring at the contacts led some persons to fancy that the instrument was intended to be shouted or sung to so loudly that every vibration should make the upper contact-piece jump up from the lower, and as Professor Müller even suggests (p. 98), produce a spark! But such a manner of using the instrument would entirely defeat Reis’s most fundamental principle, that the interruptions should be such as to correspond to the *undulating curve* which represents the pressure due to vibration of the sound-wave; the possibility of representing the degree of pressure by a curve being one of the two principles set forth in his paper “on Telephony” (p. 55), in which he remarks, that “Taking my stand on the preceding principles, I have succeeded in constructing an apparatus by means of which I am in a position to reproduce ... even to a certain degree the human voice.” Reis was perfectly well aware, as his curves show, that a complicated sound-wave does not consist invariably of *one* condensation followed by *one* rarefaction, but that there are all sorts of degrees of condensation which may follow one another, and all capable of being represented by a curve. If all sounds consisted of one rarefaction following immediately after each one condensation there might be some propriety in proposing that after each “make” of contact there should be a “break” in the sense of an abrupt or complete breach in the continuity of the current. But, obviously, the fact that

one condensation may follow another without a rarefaction between (which Reis's curves show that he knew) must be amply sufficient to prove that on Reis's own principle *his interruptor was meant to produce variations in the degree of contact in exact correspondence with the variations in the degree of pressure*, whatever these might be. Had he not meant this, he could not have talked about "taking his stand" on the principle of representing varying pressures by an undulatory curve. Now, from what has been adduced, the following points are clear:—

Firstly, that the contact-regulator which Reis combined with the tympanum was meant to interrupt the current, more or less, according to the varying movements imparted to it by the voice.

Secondly, that Reis intended such interruptions or variations of contact to be proportional to, or to "correspond" with, the variations indicated by the undulatory curve of varying pressures.

Thirdly, that for the purpose of preventing the occurrence of abrupt breaks in the continuity of the circuit, he used springs and adjusting screws, and in one form availed himself of the inertia of the moving parts to attain a similar end.

It is also clear from his own prospectus, that he was aware that for the simpler and ruder purpose of transmitting musical airs, in which the number of the vibrations is the only consideration and where each single condensation is actually followed by a rarefaction, actual abrupt breaks in the continuity of the circuit are admissible. Reis chose this simple case as the one capable of being readily grasped by a general audience, though it was obviously only a partial explanation of the action of the apparatus in the simplest case that could be presented.

Turning now to some of the more modern transmitters, we will inquire how far Reis's fundamental principles are involved in their construction. We will first take Berliner's transmitter, of which [Fig. 43](#) is a drawing, reproduced from the sketch in the specification of his British Patent. This transmitter consists of a tympanum of thin metal to collect the sound-waves, and behind it is attached an interrupter or current regulator, identical in almost every respect with that of Reis. One of the contact-pieces, marked *E*, circular in form, is fixed to the centre of the tympanum, and vibrates with it,

precisely as in Reis's latest, and in some also of his earlier instruments. Against this there rests in light contact a second contact-piece, in the form of a small blunt spike, *F*, screwed into a short arm, loosely jointed to the part *N*, where the circuit is connected. As in Reis's latest transmitter ([Fig. 17](#), p. 27), so here, the contact-pieces are kept in contact by gravity. When any person talks to the tympanum it vibrates, and, as a result, the degree of contact between the two surfaces is varied, resulting in a greater or less interruption of the current, the inertia of the upper contact-piece, serving to prevent complete abrupt "break" of the circuit, except under unusually strong vibrations. In fact, if the speaker talks too loudly when speaking into Berliner's transmitter, he will cause abrupt breaks to occur instead of partial interruptions; and a rattling noise comes in to confuse the speech at the receiving end of the line. But this is precisely what occurs in a Reis's transmitter if one talks too loudly to it. It is obvious that if Berliner's transmitter is a "make-and-break" instrument, so is Reis's, because the principle of action is identical: and it is also obvious that if Berliner's instrument is capable of varying the resistance at the contact-points by interrupting the current in a manner corresponding to the pressures of the air in the sound-waves, so also is Reis's instrument.

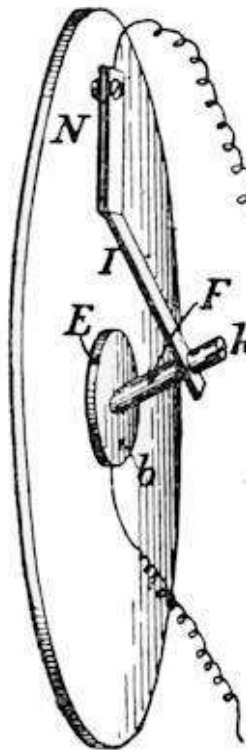

Fig. 43.

It is a fact that in Berliner's instrument it is usual to make the contact-pieces, or one of them, of hard artificial coke-carbon, as this substance will neither fuse nor rust. But Berliner's transmitter will transmit speech perfectly if the contact parts be of brass, silver, platinum, carbon, or almost any other good conductor. In most of Reis's instruments the contact-pieces were usually of platinum; but they work quite as well if artificial coke-carbon is substituted. In fact, Reis's principle of variable and elastic contact is applicable to contact-pieces of *any material that is a good enough conductor of electricity* and hard enough for the purpose. The main improvement in Berliner's transmitter is the substitution of the metal tympanum for the membranous one, which was liable to become flabby with moisture.

We pass on to Blake's transmitter, which is the one more generally used in Great Britain than any other. The drawing, [Fig. 44](#), of this instrument is taken from the specifications of Blake's British Patent, and shews all that concerns the

contact-parts. It does not show the accessories, the induction-coil, or the form of adjusting screw and frame peculiar to this instrument. Inspection of the figure shows that this transmitter consists of a mouthpiece in the form of a conical hole bored through a stout plank of wood, and closed at the back by a metal tympanum of exactly the same size as that of Reis, behind which the interruptor is placed, precisely as in some of Reis's instruments. In this interruptor both the contact-parts are supported on springs, resembling, even in the curve given to them, the springs Reis used. The first of the contact-pieces is a small metal spike. Concerning it Mr. Blake remarks (page 4 of Specification):—"It is desirable that it should be formed of, or plated with, some metal, like platinum or nickel, which is not easily corroded. It may be attached directly to the diaphragm, but I prefer to support it independently, as shewn, upon a light spring." ... "This method of supporting the electrode *ensures its contact* with the other electrode *under some circumstances when otherwise they would be liable to be separated and the circuit broken.*" In fact this spring serves functions precisely identical with those of the springs used by Reis. The second of the contact-pieces may be described as a mass of metal at the end of a spring. Of it the patentee remarks:—"This weight may be of metal which may serve directly as the electrode, but I have obtained better results by applying to it, at the point of contact with the other electrode, a piece of gas-coke or a hard-pressed block of carbon." As a matter of fact, a mass of silver or of nickel or of platinum will transmit talking perfectly, but these metals, though better conductors, are more liable to corrode and fuse, and may require therefore more frequent renewal, than gas-coke. Since, then, it is immaterial to the action of a Blake transmitter what substance is used for the contact-pieces, it is clear that the principle of employing an interruptor mounted on springs is the real feature of the instrument. Reis also mounted his interrupters with springs, and for the very same purpose. The function of the weight on the second spring of the Blake transmitter is to resist the movement of the tympanum, and to "modify by its inertia the variations of pressure" between the two contact-pieces. In other words, it acts partly as Berliner's

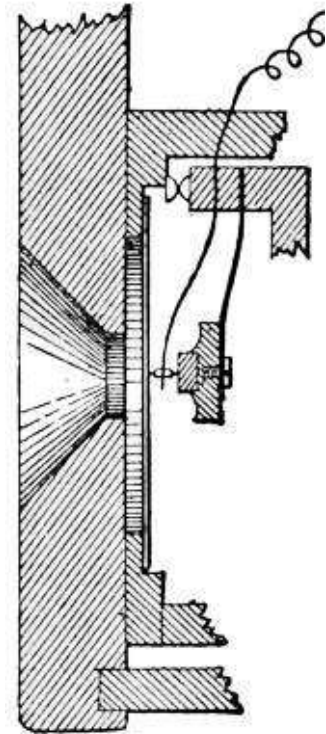

Fig. 44.

transmitter, by inertia. So did one of Reis's instruments, as we have seen. In the Blake instrument there is the happy idea of applying both the spring-principle and the inertia-principle at once. Yet, in spite of this, if the speaker shouts too loudly into a Blake transmitter, he will cause abrupt breaks between the contact-pieces instead of producing partial interruptions in the contact, and in that case speech will, as heard at the other end of the line, be spoiled by a rattling noise. It is possible, also, with Reis's instruments to spoil the articulation by shouting too loudly, and causing actual abrupt breaks in the continuity. If Blake's interruptor can be worked as a make-and-break in this sense, so can Reis's: for there is not one of the features which is essential to Blake's instrument that cannot be found in Reis's also.

By way of further carrying out the comparison between Reis's methods of combining his tympanum with his contact-regulator, and the methods adopted by later inventors, we give, in [Fig. 45](#), ten comparative sketches, the first five of which illustrate Reis's methods. In these sketches the only liberty taken is that of representing no more of the instruments than the actual parts wanted in the comparison. No. 1 represents the working-parts of Reis's first model ear, with its curved lever, platinum-tipped spring, and adjusting screw. No. 2 shows the springs, screw, and contact-pieces of Reis's bored-block transmitter ("fourth form:" compare Figs [9](#) and [10](#), p. 21). No. 3 shows the curved lever, the springs, and the adjusting screw of Reis's eighth transmitter ("lever" form). No. 4 gives the working parts of Reis's ninth transmitter, described in detail on p. 27. No. 5, in which the tympanum is placed in a vertical position, merely for convenience of comparison with the other figures, shows the working parts of Reis's final form of instrument, in which gravity and the inertia of the upper contact-piece enabled him to dispense with the adjustment of spring and screw. No. 6 shows in profile Berliner's transmitter, which may be instructively compared with No. 5. No. 7 shows the working part of Blake's transmitter, which should be compared with Nos. 2 and 4: even the curve of the springs imitates that adopted by Reis. Nos. 8, 9, and 10 are forms of transmitter devised by Edison. No. 8 is copied from [Fig. 10](#) of the specification of Edison's British Patent. It will be seen that here there is an interruptor placed on each side of the tympanum, and that each interruptor consists of a short spike mounted on a spring and furnished with an adjusting-screw. "Platina foil disks," says the inventor, are to be secured to each side of the diaphragm, and against these disks, as in Reis's instruments, press the contact-points of the interruptors. The patentee also states (p. 7 of his Specification), that for these contact-points "any substance not liable to

rapid decomposition” may be used. This term includes all the substances used by Reis, and a great many others. It will therefore be seen that this whole device is nothing more than a Reis transmitter with the contact parts duplicated. Yet this instrument was intended by Edison to transmit speech, and will, like Reis’s instrument, transmit speech if properly used. No. 9 of the set of sketches is taken from [Fig. 25](#) of Edison’s British Specification, but omits the induction-coil and other accessories, retaining the parts wanted for comparison. The patentee thus describes the parts figured. “The tension-regulator [meaning thereby the interruptor or contact-regulator] is made of platina-foil upon the surface of two soft rubber tubes; one on the diaphragm, the other on the adjusting-screw.” It is interesting to note here how the ingenuity of the later inventor led him to vary the construction adopted by the original inventor in substituting an elastic cushion of soft rubber for the springs of the older instruments. But the principle of combining a tympanum with a contact-regulator, which was Reis’s fundamental notion, is here also the leading idea; and the further idea of obviating abrupt breaks in the current by applying elastic supports is also carried out. Edison even copies Reis in having an adjusting-screw, and he applies the very same substance—platinum foil—which Reis used in his very first and his very last transmitter. Edison’s transmitter transmits speech very fairly, even without any of such later accessories as induction-coils; and why should it not? It is constructed on the very lines, nay, with details almost identical with those prescribed by Reis in describing his invention. It embodies those fundamental ideas which Reis set before him when he said, “Taking my stand upon the preceding principles, I have succeeded.”

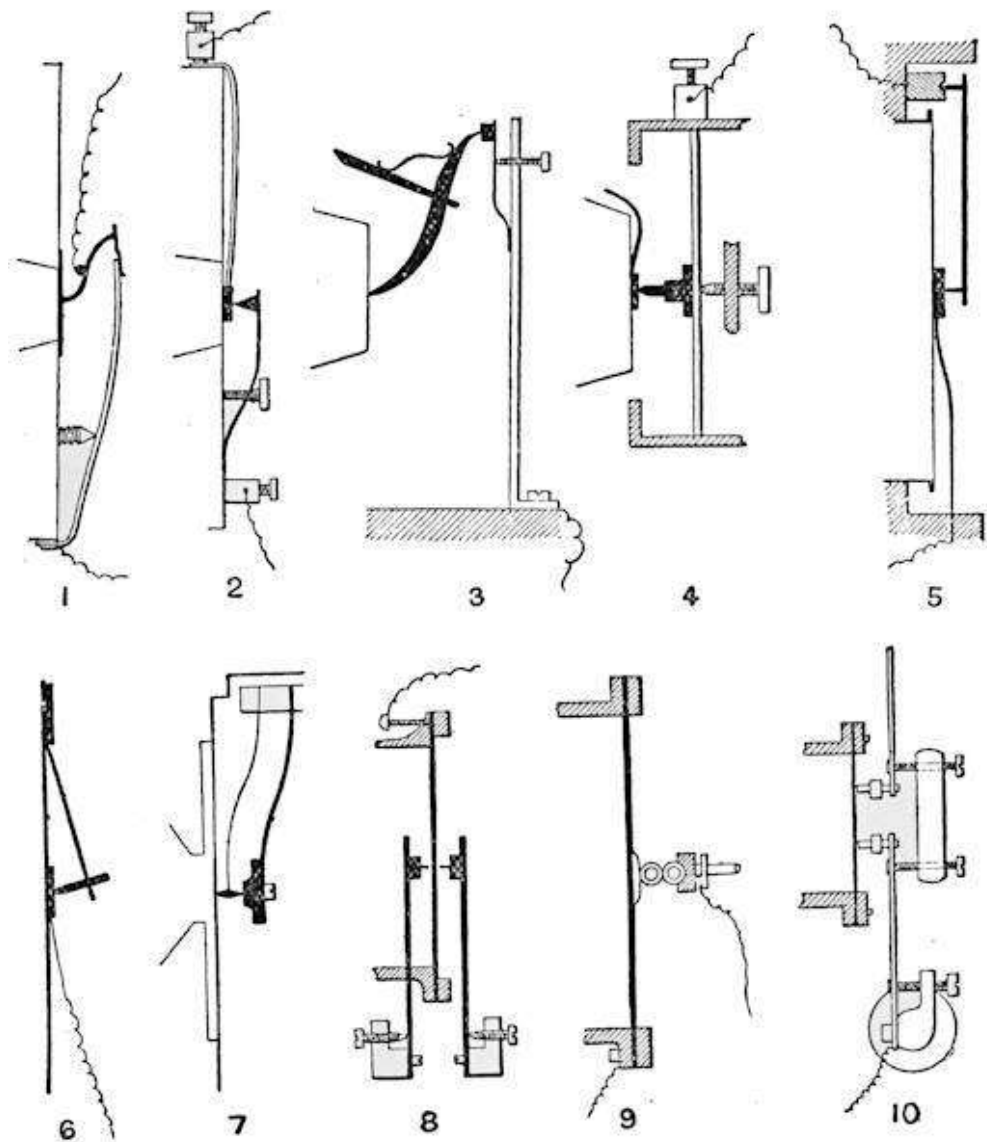

Fig. 45.

The last of the ten sketches of [Fig. 45](#) is taken from Edison's first American Patent specification [No. 203,014, filed July 20, 1877], and shows a duplicated interrupter with springs and adjusting-screws combined with a tympanum. Further comment on this arrangement is needless, save to remark that in this patent for "*speaking* telegraphs," Edison himself describes the contact-apparatus which Reis termed an "interrupter," as a "circuit-closer," or in another place as "circuit-breaking connections," and, in his British Patent quoted above, as a "tension-regulator." It is evident that if Reis could transmit speech by an interrupter which closed and opened the circuit (always in proportion to the vibrations) there is no reason why Edison seventeen years afterwards should not accomplish the same result by a similar means. But it has lately been fashionable to deny that any such device as an interrupter mounted on springs can transmit speech at all!

We have now compared with Reis's transmitters several of the more modern inventions. It would be possible to carry comparison further were that course needed. We have not thought it worth while to rake up Edison's now discarded lamp-black button transmitter; and we have not yet spoken of Crossley's transmitter nor of Theiler's transmitter, nor of their parent the Hughes' microphone, nor of dozens of other forms. In some of these there is no specific "tympanum," but only a sounding-board of pine-wood, and in most of them the points of loose-contact, where interruption more or less complete may occur, are multiplied. But they all come back in the end to Reis's fundamental idea, namely that of setting the voice to vary the degree of contact in a mechanism which he called an interruptor, and which others have called a current-regulator (or, less correctly, a tension-regulator) which, because the degree of contact between its parts was varied, caused those parts to offer more or less resistance to the flow of the current, and thereby threw it into vibrations corresponding to those of the sound-wave impressed upon the tympanum. There is not a practical transmitter used in any of the telephone exchanges of Great Britain to-day that does not embody this principle.

Reis did, indeed, penetrate to the very heart the principles necessary to be observed in a successful telephone. He was master of the situation. For, as in every practical transmitter in use to-day, so in his transmitter, there was *a loose contact in the circuit so arranged that the voice could act upon it, and thereby regulate the strength of the current*. If you eliminate this part of the apparatus,—screw up the loose-contacts of your transmitters, so that your voices cannot affect them,—what will your telephones be worth? No: the essential principle of the transmitter—"Das Telephon" emphatically as its inventor styled it—is *variable contact*; and that all-essential principle was invented and applied for the purpose of transmitting speech by Philipp Reis in 1861.

If this does not suffice as a claim for the invention of the Telephone transmitter, it may well be wondered what will. We can dispense with all other features save this one. We can even dispense with the tympanum or diaphragm which Reis introduced, and can operate on the contact-parts without the intervention of this part of the combination. We can use the very metals which Reis used, and dispense with lamp-black and all the fallacious rubbish that has been subsequently devised about semi-conductors, whatever that term may mean. We can even dispense with springs and adjusting screws. *But with the principle of variable contact we can not dispense*. That which alone is indispensable Philipp Reis discovered.

APPENDIX II.

ON THE VARIATION OF ELECTRIC RESISTANCE AT A POINT OF IMPERFECT CONTACT IN A CIRCUIT.

Ever since electricians had experimented with voltaic currents, and especially since the introduction of the electric telegraph, it had been a familiar fact that a loose or imperfect contact in the circuit caused a resistance to the flow of the current and interrupted it more or less completely. To obviate the occurrence of loose or imperfect contacts, binding-screws were invented; and many were the precautions taken to make tight contacts at joints in the line, the resistance of which it was desirable to maintain at a minimum. Young telegraphists were particularly instructed to press their keys well down in signalling, because a light contact would offer some resistance which, on an increase of pressure, would disappear. In fact, it was generally well known that the resistance of two pieces of metal or other conducting material in contact with one another might be made to vary by varying the goodness or badness of the contact with the application of more or less force. This fact was known to apply to good conductors, such as copper and other metals, and it was known to apply also to non-metallic conductors, such as plumbago. Plumbago points were used by Varley for the contacts of relays; it having been found that points of platinum were liable to become fused together with the passage of the current, and by so sticking rendered the instrument useless. Since plumbago was known to be infusible, it was hoped that a plumbago contact would prove more reliable. In practice, however, the plumbago relay did not turn out so well. True it did not fuse, or stick, or rust; but it was even more liable than platinum to form imperfect contacts, the resistance of the light contact being so high that a sufficient current did not pass. It is not known whether other non-metallic substances were tried; probably not, because of non-metallic substances plumbago is one of the few that are good conductors.

According to Edison (British Patent, No. 792, 1882), compressed graphite is a substance of *great conductivity*. According to Faraday ('Exp. Res.' vol. i. p. 24), retort-carbon is an *excellent conductor*. Both graphite and retort-carbon agree with the metals in the property that the electric resistance offered at a point of contact between them varies when the pressure at the contact is varied. It is indeed remarkable through what wide ranges of resistance the contact between two good conductors may vary. The resistance of contact between two pieces of copper may be made to vary in a perfectly continuous manner by changes of pressure through a range, according to Sir W. Thomson, from a small fraction of one *ohm*, up to a resistance of many thousand *ohms*. The same is true of silver, brass, and many other good conductors, including graphite and retort-coke, though with the latter materials the range of resistances is not so great. With partial conductors, such as oxide of manganese, sulphide of copper, sulphide of molybdenum, &c., and with bad conductors, such as lamp-black and selenium, whose conductivity is millions of times less than that of graphite, copper, and other good conductors, it is impossible to get equally wide variations of resistance, as the amount of pressure at a point which will bring the bad conductors into intimacy of contact, will not turn them into good conductors. Platinum being in the category of good conductors, is amongst those substances which yield a very wide range of electrical resistances at the contact-points which are submitted to varying pressures.

With the very highest conductors, such as silver and copper, the electrical range of contact-resistance is higher than with those of lesser conductivity, such as lead, platinum, graphite, and retort-coke.

But though the range of variation in electrical resistance at contacts is highest for the best conductors, there comes in another element, namely, the range of distance through which the contact-pieces, or either of them, must be moved in order to pass through the range of variations of resistance. This is quite a different matter, for here the best conductors have the smallest range, and some that are not so good a greater range. In any case the available range of motion is very small—to be measured in minute fractions,—millionth-parts, perhaps,—of an inch. So far as experiments go, however, silver has the smallest range of all, then gold, then copper. Platinum and nickel have a considerably wider range, plumbago and retort-coke a still wider one.

It is an extremely difficult matter to decide what is the precise nature of that which goes on at a point of contact between two conductors when the pressure at the point is altered. The principal suggestions hitherto advanced have been that the change of resistance observed is due:—

- (a) To the mere changes in the amount of surface in contact.
- (b) To a change in the resistance of the substance of the conductor itself.
- (c) To the formation of a minute voltaic “arc,” or electric discharge.
- (d) To the change in the thickness of the intervening film of air.
- (e) To the change in resistance of the parts in contact consequent on the evolution of heat by the current.

It is admitted that this last suggestion, though it might account for a difference between different substances, in so far as they differ from one another in the effect of heat upon their specific resistance, implies as a preliminary fact that the amount of surface in contact shall be varied by the pressure. No convincing proof has yet been given that the alleged layer of air or other gases has any real part to play in the phenomena under discussion. Nor can the hypothesis, that minute voltaic arcs are formed at the contact be regarded as either proven or probable.

The only two theories that have really been investigated are (a) and (b) of the above series. Of these two (b) is certainly false, and (a) is probably, at least to a very large extent, true.

It is often said by persons imperfectly acquainted with the scientific facts of the case, that carbon is used in telephone-transmitters, because the resistance of that substance varies with the pressure brought to bear upon it, whilst with metals no such effect is observed. This statement, taken broadly, is simply false. Mr. Edison has, indeed, laid claim to the “discovery” (*vide* Prescott’s ‘Speaking Telephone,’ p. 223), that “semi-conductors,” including powdered carbon and plumbago, vary their resistance with pressure. All that Mr. Edison did discover was that certain substances, whose properties of being conductors of electricity had been known for years, conducted better when the contact between them was screwed up tightly than when loose. The experiments made to test this alleged “property” of carbon are absolutely conclusive. The author of

this book has shown^[39] that when a rod of dense artificial coke-carbon, such as is used in many forms of telephone transmitters, such as Crossley's for example, is subjected to pressure varying from less than one dyne per square centimetre up to twenty-three million times that amount, the resistance of the rod did not decrease by so much as one per cent. of the whole. In this case any doubt that might have been introduced by variable contact was eliminated at the outset by taking the precaution of electro-plating the contacts.

In 1879, Professors Naccari and Pagliani, of the University of Turin, published an elaborate series of researches^[40] on the conductivity of graphite and of several varieties of coke-carbon, and found, even with great changes of pressure, that the changes of electric resistance were practically too small to be capable of being measured, and that the only changes in resistance appreciable were due to changes of contact.

In January 1882, Mr. Herbert Tomlinson communicated to the Royal Society^[41] the results of experiments on a number of electric conductors. The change of conductivity by the application of stress was found to be excessively small. For carbon it was less than one-thousandth part of one per cent. for an increase of fifteen lbs. on the square inch in the pressure. For iron it was slightly greater, and for lead nearly twice as great, but with all other metals less. If this alleged property were the one on which the action of telephone transmitters depended, then lead ought to be twice as good a substance as graphite; whereas it is not nearly so good.

Professor W. F. Barrett, in 1879,^[42] made some experiments on the buttons of compressed lamp-black used in Edison's transmitter, and found that when an intimate contact was satisfactorily secured at the beginning, "pressure makes no change in the resistance."

In the face of all this precise evidence, it is impossible to maintain the theory that the electric resistance of plumbago or of any other such conductor varies under pressure. The only person who has seriously spoken in favour of the theory is Professor T. C. Mendenhall, but in his experiments he took no precautions against variability of contacts, so that his conclusions are invalid.

More recently still, Mr. O. Heaviside and Mr. Shelford Bidwell have experimented on the variations of resistance at points of contact.^[43] Mr. Heaviside's experiments were confined to contacts between pieces of carbon, and though extremely interesting as showing that the resistance of such contacts are not the same, even under constant pressure, when currents of different strength are flowing, do not throw much light on the general question, because they leave out the parallel case of the metals. Mr. Bidwell's very careful researches were chiefly confined to carbon and bismuth. The choice is unfortunate, because bismuth the most fusible and worst conductor amongst metals (save only quicksilver) is the one metal *least* suited for use in a telephone transmitter. Mr. Bidwell's conclusions, so far as they are comparative between carbon and "the metals," are therefore necessarily incomplete.

Professor D. E. Hughes, whose beautiful invention, the Microphone, attracted so much attention in 1878, has lately thrown the weight of his opinion in favour of the view that with carbon contacts the effect is due chiefly to an electric discharge or arc between the loosely-contiguous parts. But Professor Hughes's innumerable experiments entirely upset the false doctrine that a "semi-conductor" is necessarily required for the contact-parts. Speaking recently,^[44] he has said: "I tried everything, and everything that was a conductor of electricity spoke." In 1878, in a paper "On the Physical Action of the Microphone," Professor Hughes stated:^[45] "the best results as regards the human voice were obtained from two surfaces of solid gold." Hughes also found carbon impregnated with quicksilver in its pores to increase its conducting power to work better than non-metallised carbon of inferior conductivity. Quite lately Mr. J. Munro has constructed successful transmitters of metal gauze, having many points of loose-contact between them.

It seems, therefore, much the most probable in the present state of investigations, that the electric resistance of a contact for telephonic purposes is determined solely by the number of molecules in contact at the surface, and by the specific conductivity of those molecules. The element of fusibility comes in to spoil the constancy of the surfaces in action; and hence the inadmissibility of general conclusions with respect to all metals drawn from the behaviour of the most fusible of them. At a mere point in contact physically with another point, there may be

hundreds or even millions of molecules in contact with one another, all acting as so many paths for the flow of the electric current. An extremely small motion of approach or recession may suffice to alter very greatly the number of molecules in contact, and the higher the specific conductivity of the substance, and the denser its molecules, the shorter need be the actual range of motion to bring about a given variation in the resistance offered. Just as in a system of electric lamps in parallel arc, the resistance of the system of lamps increases when the number of lamps through which the current is flowing is diminished, and diminishes when the number of lamps connecting the parallel mains is increased; so it is with the molecules at the two surfaces of contact. Diminishing the number of molecules in contact increases the resistance, and *vice versâ*. Each molecule as it makes contact with a molecule of the opposite surface diminishes, by so much relatively to the number of molecules previously in contact, the resistance between the surfaces. Each molecule as it breaks from contact with its opposite neighbour adds to the resistance between the contact-surfaces. It may therefore be that the variations of resistance which are observed at contacts between all conductors, from the best to the worst, are all made up, though they *appear* to pass through gradual and continuous changes, of innumerable minute makes-and-breaks of molecular contact. The very minuteness of each molecular make-or-break, and the immense number that actually must occur at every physical “point” of contact, explain why the effect seems to us continuous. We owe, moreover, to Mr. Edison^[46] the experimental proof that actual abrupt makes-and-breaks of contact *can* produce an undulating current when they recur very rapidly. Whether the heating action of the current itself may not also operate in changing the conductivity of the molecules which happen at the moment to be in contact is another matter. It may be so; but if this should hereafter be demonstrated, it will but confirm the contact-theory of these actions as a whole.

Assuming, then, broadly, that the observed resistance at a point of contact is due to the number of molecules in contact and to their individual resistances, it is evident that the property of varying resistance at contact ought to be most evident, *ceteris paribus*, in those substances which are the best conductors of electricity. Unfortunately, the *cetera* are not *paria*, for the question of fusibility comes in to spoil the comparison;

and carbon, which has less fusibility than the metals, is commonly credited with giving a better result than any. This common opinion is, however, based on comparisons made without taking into consideration the question of range of motion between the parts in contact, and without taking into consideration the point that whilst some forms of carbon are excellent conductors, others do not conduct at all. In a telephonic transmitter so arranged that the actual range of motion shall be very small, the metals are just as good as carbon—some of them better. I have heard from a transmitter with contacts of pure bright silver better articulation than with any carbon transmitter. And this is exactly what theory would lead one to expect. As to the suggestion that plumbago makes a successful transmitter, because it is a “semi-conductor”—whatever that term may mean^[47]—it is one of those suggestions which are peculiarly fitted to catch the unscientific mind as affording an easy explanation for an obscure fact; unfortunately, like a good many other similarly catching suggestions, *it is not true*. The very best conductor—*silver*—will serve to transmit articulate speech: and so will the one of the very worst conductors—*lamp-black*! So much for this fallacious doctrine of semi-conductors!

Reis used for his contact-points substances which, by reason of their non-liability to fuse or oxidize, were customary in electrical apparatus, and chiefly platinum. In his earliest transmitter (model ear), and in his last, platinum was used. In his lever-form of transmitter, so minutely described by von Legat, the material is not specified. The lever-shaped contact-piece was to be a conductor, and as light as possible, and since all metallic parts are particularly described as metallic, whilst this is not so described, the obvious inference is that this was non-metallic. The number of light, non-metallic conductors is so few that the description practically limits choice to some form of hard carbon. No other materials are named by Reis, but Pisko says (p. 103) that brass, steel, or iron might be used for contacts. Any one of these materials is quite competent, when made up into properly-adjusted contact-points, to vary the resistance of a circuit by opening and closing it in proportion to the vibrations imparted to the contact-points. That is what Reis’s transmitter was intended to do, and did. That is what all the modern transmitters—Blake’s, Berliner’s, Crossley’s, Gower-Bell’s, Theiler’s, Johnson’s, Hunning’s do, even including Edison’s now obsolete lamp-black button transmitter. Mr.

Shelford Bidwell has very well summarized the action of the current-regulator in the following words: “The varying pressure produces alterations in the resistance at the points of contact in exact correspondence with the phases of the sound-waves, and the strength of a current passing through the system is thus regulated in such a manner as to fit it for reproducing the original sound in a telephone.”

Reis constructed an apparatus consisting of a tympanum in combination with a current-contact-regulator, or “interruptor,” which worked on this principle of variable contact, and he called it “The Telephone” (see pp. 57, 85). The very same apparatus we now-a-days call a “Telephone-transmitter,” or simply a “transmitter.” It is curious to note that Reis seems to have regarded his receiver or “reproducing-apparatus” as no new thing. He says explicitly (p. 56) that his receiver might be replaced by “any apparatus that produces the well-known galvanic tones.” “*The Telephone*” was with Reis emphatically the *transmitter*. Bell in 1876 invented an instrument which would act either as transmitter or receiver, and which, though never now used as transmitter, is still called “a Telephone.” Edison’s “sound-telegraph,” or “telegraphic apparatus operated by sound,” was patented in 1877. In his specification *he never called his transmitter a “telephone;”* that name he reserved exclusively for his receiver. He found it, however, convenient a year later to rechristen his transmitter as the “*carbon telephone,*” though throughout the whole of his specification *neither “carbon” nor “telephone” are mentioned* in connection with the transmitter! Within that year Hughes had brought out another instrument—“The Microphone”—which, like Reis’s instrument, embodied the principle of variable contact. Hughes’s instrument, usually constructed with contacts made of loose bits of coke-carbon, was simply a Reis’s Telephone minus the circular tympanum; and the really important new fact it revealed, was that very minute vibrations, such as those produced by the movements of an insect, when transmitted immediately through the wooden supports, sufficed to vary the resistance of a telephonic circuit, though far too slight in themselves to affect it if they had to be first communicated to the air and then collected by a tympanum. Put a specific tympanum to a Hughes’s microphone, and you get a Reis’s telephone. Take away the tympanum from a Reis’s telephone, and you get a Hughes’s microphone. Hughes is not limited to one material, nor is Reis. But the fundamental principle of the electrical part of each is identical. The Blake transmitter

([Fig. 44](#)), and the Berliner transmitter, and also Lüdte's microphone, [48] which was even earlier than that of Hughes, are all embodiments of the same fundamental principle of variable contact which Reis embodied in his "Telephone."

The numerous experiments which Reis made, and the many forms of instruments which he devised, prove his conviction of the importance of his invention to have been very deeply rooted. He had indeed penetrated to the very soul of the matter. He did not confine himself to one kind of tympanum, he tried many, now of bladder, now of collodion, now of isinglass, and now of thin metal. He varied the forms of his instruments in many ways, introducing the element of elasticity by springs and adjusting-screws. Though he chiefly employed one metal for his contact-pieces, he did not limit himself to that one, but left us to infer that the principle of variable contact was applicable to any good conductor, metallic or non-metallic. He knew better, indeed, than to limit himself in any such fashion; better, indeed, than some of the eminent persons who are now so willing to ignore his claims. Modern practice has taught us to improve the tympanum part of Reis's invention, and to obviate the inconveniences to which a membrane is liable: in that part we have gone beyond Reis. But in the question of contact-points for opening and closing the circuit in correspondence with the vibrations, we are only beginning to find how much Reis was a-head of us. We have been thrown off the track—blinded perhaps—by the false trail of the "semi-conductor" fallacy, or by the arbitrary and unnatural twist that has been given by telegraphists to Reis's expression, "opening and closing the circuit," forgetting that he practically told us that this operation was to be proportional to, "in correspondence with," the undulations of the tympanum. When we succeed in freeing ourselves from the dominance of these later ideas, we shall see how much we still have to learn from Philipp Reis, and how fully and completely he had grasped the problem of the Telephone.

APPENDIX III.

COMPARISON OF REIS'S RECEIVERS WITH RECENT INSTRUMENTS.

The receivers invented by Reis for the purpose of reconverting into audible mechanical vibrations the varying electric currents transmitted from the speaking end of the line were of two classes, viz.:

(1.) Those in which the magnetic expansion and contraction of a rod of steel or iron, under the influence of the varying current, set up mechanical vibrations and communicated them to a sound-board.

(2.) Those in which the current by passing round the coils of an electro-magnet caused the latter to vary the force with which it attracted its armature, and threw the latter into corresponding mechanical vibrations.

The first of these principles is embodied in the "knitting-needle" receiver described above and depicted in figures 22 & 23 on page 33. This receiver differs wholly from the later instruments of Bell, and others, and depended for its action upon the phenomenon of magnetic expansion discovered by Page and investigated by Joule. It was well known before Reis's time that when a needle or bar of iron was magnetised it grew longer, and when demagnetised it grew shorter. Page detected the fact by the "tick" emitted by the bar during the act of magnetisation or demagnetisation. Joule measured the amount of expansion and contraction. To these discoveries Reis added two new facts; *first*, that if the degree of magnetisation be varied with rapid fluctuations corresponding to those of the sound waves impressed on the transmitter, the expansion and contraction of the rod followed these fluctuations faithfully, and therefore emitted at the receiving end sounds similar to those uttered at the transmitter. *Secondly*, by employing a needle of *steel* instead of the bar of iron used by Page, Reis obtained an instrument which once used could never become completely demagnetised on the cessation of the current; it was thenceforth a *permanent magnet*, and all that the fluctuating currents could do was to vary its degree of magnetisation. Reis carefully explained in his memoir "On Telephony," how the frequency of such fluctuations in the magnetising

current could act in reproducing the pitch, and further, how the amplitude of the fluctuations set up vibrations of corresponding amplitude in the rod: he added with significance, that the quality of the reproduced note depended upon a number of variations of amplitude occurring in a given time. His theory of these actions was that the atoms (or perhaps our modern word *molecules* would more correctly represent what Reis spoke of as atoms) of the rod or needle were pushed asunder from one another in the act of magnetisation, and that on the cessation of the magnetising influence of the current, these same atoms strove to return to their previous position of equilibrium, and thus the oscillations of the atoms led to the vibration of the needle as a whole. Whether all Reis's speculations as to the behaviour of the atoms under varying degrees of magnetising force are justified in the present aspect of science or not, is, however, not of any great importance; the important point is, that, whether his theory be right or wrong, the instrument he devised will perform the function he assigned to it: it will reproduce speech, not loudly, but in reality far more articulately than many of the telephonic receivers in use under the names of Bell, Gower-Bell, &c.

One very curious point in connection with this "knitting-needle" receiver of Reis, is its extremely bad acoustical arrangements. It was laid horizontally upon a small sounding-board covered by a lid. If the *end* of the needle had been made to press on the resonant-board (as indeed appears to have been done at first with the violin, p. 29) the vibrations would have been much more directly reinforced. But when merely supported by two wooden bridges the direct communication was largely lost. The pressure of the lid downwards upon the spiral, as recommended by Reis, is no doubt an important matter acoustically. It is strange that a man who had grappled in so masterly a way with the acoustical problem of the transmitter, and had solved it by constructing that transmitter on the lines of the human ear, should not have followed out to the same extent those very same principles in the construction of his receiver. An extended surface he did employ, in the shape of a sounding-board; but it was not applied in the very best manner in this instrument.

The second principle applied by Reis in the construction of his telephone-receivers, was that of the electro-magnet. He arranged an electro-magnet so that the fluctuating currents passing round the coils set up corresponding variations in the degree of force with which it attracted its armature of iron, and so forced the latter to execute corresponding mechanical vibrations. This principle is common both to the receiver of Reis, and to the later receivers of Yeates, Bell, and Edison. Reis's armature

was an iron bar of oval section; Yeates's an iron strip screwed to a sound-board, Bell's was an iron plate, and Edison's an iron plate also.

For the better comparison of Reis's electro-magnetic receiver with those of more modern date, we here present in [Fig. 46](#) a comparative view of a number of different forms of receiver in which Reis's principle of causing an electro-magnet to set up vibrations in an armature is applied. In this set of figures, *A* and *B* are the suggested forms mentioned in the letter of Mr. Horkheimer, p. 119, and show an electro-magnet, opposite the poles of which is placed an armature (a bar) which must be of iron or other metal capable of having magnetism induced in it, and which, by reason of its attachment to an elastic spring, is capable of being made to oscillate to and fro when attracted with a varying force. Reis clearly recognised the necessity of further providing a sufficient resounding surface by means of which the surrounding air could be set in motion: for in the case of these two suggestions the electro-magnet and its elastically-mounted armature were placed within a cigar box. *C* is a plan of the receiving instrument previously described and figured in Plate II. and in figures 21 and 34 on pages 32 and 109. In this instrument the electro-magnet was horizontal, the armature, a bar of iron of oval section (which in the original drawing in plate II. appears to have been in reality a hollow bar or tube) attached to a thin lever described as a plank, pivoted like a pendulum to an upright support, but prevented by a set-screw and a controlling spring from vibrating in the manner of a pendulum. Such an arrangement, in fact, vibrates in perfect correspondence with any vibrations that may be forced upon it by the electro-magnet. The broad flat surface of the lever—specially directed that it should be broad and light—transfers the vibrations to the air, and is aided by the surface of the sounding-board on which the apparatus stands. This apparatus has, therefore, all the elements of a successful receiver, except only that its shape renders it inconvenient for portability. But by reason, firstly of its armature of iron, secondly of the elastic mounting of that armature, thirdly of the extended surface presented, it is admirably adapted to serve as an instrument for reproducing speech.

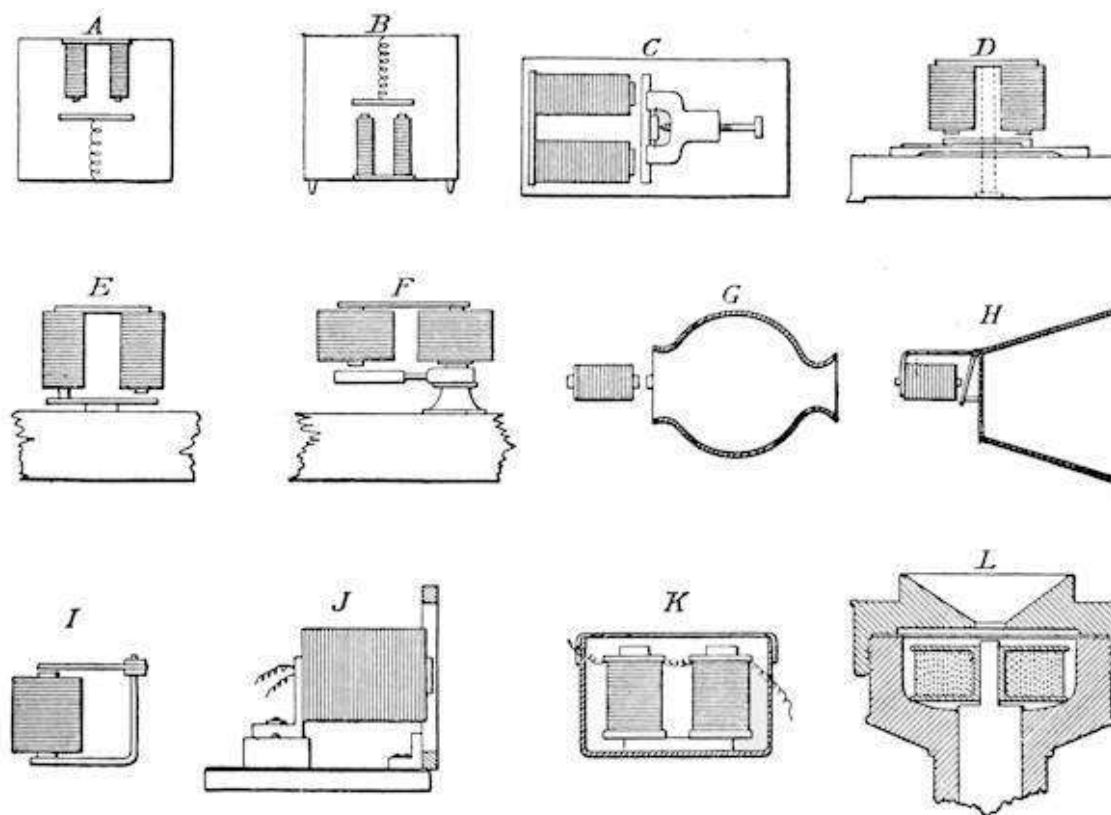

Fig. 46.

[Fig. 46](#) *D* represents the excellent electro-magnetic receiver devised in 1865 by Yeates (compare [Fig. 42](#), p. 128) to work with the Reis transmitter, and is in many respects identical with the preceding form. The armature, a strip of iron, was attached at one end by a very stiff steel spring to a pine-wood sounding-board over a hollow box, from the base of which rose the metal pillar which supported the electro-magnet. This receiver also contains all the elements of a successful receiver, the armature being of a material capable of inductive action, and elastically supported; whilst the sound-box provided adequate surface to communicate the vibrations to the air.

We now come to the more modern instruments of Gray, Bell, and Edison. So far the receivers of Reis and of Yeates were intended for reproducing any sound; but now for the first time, ten years after the date of these early telephonic receivers, we meet with instruments devised with the express purpose of receiving only certain selected tones.

For the purposes of multiple acoustic telegraphy, that is to say for the purpose of signalling the “dots” and “dashes” of the Morse code in a number of different fixed musical notes, each of which is to be signalled out and repeated by a receiver adapted to vibrate in that note alone, it is clear that the instruments of Reis, adapted as they were to transmit and receive *any* sound that a human ear can hear, would not answer. Accordingly those

experimenters, who from about the year 1873 to the year 1870, applied themselves to multiple telegraphy—foremost amongst them being Mr. Elisha Gray and Prof. Graham Bell—dropped the use of the tympanum in the transmitter and devised new transmitters and new receivers, in most of which the ruling idea was that of employing a vibrating tongue or reed, tuned up to one particular note. Now it is obvious that a receiver which, like those of Reis, is adapted to receive *any* tone, can also receive a musical note. But for the operation of “selective” reception, a receiver must be employed, not only tuned to one note, but tuned to the very note emitted by the particular transmitter with which it is to be in correspondence. Elisha Gray found this out very early in his researches. In the winter of 1873-4^[49] he was transmitting musical tones by a sort of tuning-fork interruptor, and received them on an instrument shown in [Fig. 46 E](#), which represents a form of electro-magnet mounted for the purpose. It was “a common electro-magnet, having a bar of iron rigidly fixed at one pole, which extends across the other pole, but does not touch it by about one sixty-fourth part of an inch. In the middle of this armature a short post is fastened, and the whole is mounted on a box made of thin pine, with openings for acoustic effects.” It was, in fact, very similar to Yeates’s receiver just described, and Gray found it capable of receiving not only simple musical tones but composite tones, and even harmonies and discords. In fact, like Reis’s and Yeates’s receivers, it could receive anything that the transmitter sent to it, even including speech. Now this did not suit Gray, who wished to have selective receivers, one to take up note A, another note C, &c. Accordingly in 1870 we find Gray taking out a fresh patent^[50] for selective receivers, which he also called harmonic analysers, each of which consisted of “a tuned bar or reed suitably attached to an electro-magnet, and the whole mounted upon a resonant box.” [Fig. 46 F](#) is reproduced from Gray’s British patent. “A vibrating tongue reed, or bar” of steel “is united with one pole of the magnet. The free end of the reed passes close to, but does not touch the other pole of the magnet.” Gray further says that the reed is made with parallel sides and tuned by cutting it away at one point, as this mode prevents false nodal vibrations from occurring.

Selective receivers for multiple telegraphy were also invented by Graham Bell. The form shown in [Fig. 46 I](#) is transcribed from Fig. 15 of Bell’s Specification to his British Patent, No. 4765, of the year 1876 (dated 9th December), which the inventor thus describes: “It is preferable to employ for this purpose an electro-magnet *E*, Fig. 15, having a coil upon

only one of its legs. A steel spring armature *A* is firmly clamped by one extremity to the uncovered leg *h* of the magnet, and its free end is allowed to project above the pole of the covered leg.” In fact the arrangement was almost identical with, but not quite as good mechanically as that patented seven months previously by Gray. The inventor further said that a number of these instruments might be placed on one circuit, and that if one of them were set in vibration, only those would respond which were in unison with its note; and further that “the duration of the sound may be used to indicate the dot or dash of the Morse alphabet, and thus a telegraphic despatch may be indicated by alternately interrupting and renewing the sound.”

Anything more totally different from Reis’s telephone than these selective harmonic telegraphs with their tuned tongues can hardly be imagined. Reis was not aiming at selective harmonic telegraphy; he wanted his one instrument to transmit every sound that a human ear could hear. He did not dream of using a tuned bar or reed; his typical structure was the tympanum of the ear. In fact, as we have seen above, the tuned reed or tongue was introduced into telegraphy for the purpose of transmitting single selected notes to the exclusion of all others.

Strange though it may seem, a tongue receiver like those of Graham Bell and of Gray just described can be used for receiving speech! It is true, as Gray remarks, that a thick bar of steel, cut away as described, is best adapted for its own tone only. But Bell’s thin steel tongue, though it has its own fundamental note (and so has every tympanum, for that matter) when left free to vibrate in its own time, will reproduce *any* other note or sound that may be *forced* upon it by the varying attraction of the electro-magnet. There is, indeed, the whole difference between “free” and “forced” vibrations. One of the strangest delusions that has somehow grown up in recent telephonic discussions is the almost incredible proposition that a tongue cannot talk because it is a tongue. It would be equally veracious to affirm that an ear (*i.e.* a tympanum) cannot hear because it is an ear.

But leaving harmonic telegraphy and its “tuned bars,” both Gray and Bell applied themselves to the old problem of transmitting human speech. What was their very first step? They threw away their “tuned bars” and “steel springs,” and returned *to the tympanum*! Elisha Gray devised the receiver shown in [Fig. 46](#), *G*, taken from his caveat of date February 14, 1876.^[51] In that document Gray says: “My present belief is that the most effective method of providing an apparatus capable of responding to the various tones of the human voice, is a *tympanum*, drum, or diaphragm,”

stretched across one end of a chamber. He adds that in the receiver there is (see [Fig. 46](#), G) an electro-magnet, acting upon a diaphragm to which is attached a piece of soft iron, and which diaphragm is stretched across a vocalising chamber.

Graham Bell's receiver (the American specification of which was filed the same day as Gray's caveat) is shown (in the form patented in Great Britain, Dec. 9, 1876) in [Fig. 46](#) H, which is taken from Fig. 19 of Bell's British patent. "The armature," says the inventor, "is fastened loosely by one extremity to the uncovered leg, *h*, of the electro-magnet *E*, and its other extremity is attached to the centre of a stretched membrane." The armature, in fact, was capable of vibrating like a pendulum on its pivot, but was elastically restrained by its attachment to the tympanum; the armature would therefore vibrate in perfect correspondence with any vibrations forced upon it by the electro-magnet. This instrument as also that of Gray, was admirably adapted to receive speech, for it embodied the three essential points which Reis had already discovered: viz., firstly, that the armature must be of iron, or capable of being acted upon by magnetic induction; secondly, that it must be elastically mounted; thirdly, that it should present an extended surface. Bell's form of receiver had the advantage over Reis's (compare p. 158), that its extended surface was a true tympanum of membrane, and not a mere broad thin plank. Being a tympanum, it therefore realised Reis's fundamental notion of imitating the human ear more fully than even Reis's own receiver did.

Figures [46](#), J, K, and L represent the more recent types of receiver of Bell and Edison. [Fig. 46](#) J is reproduced from Fig. 20 of Bell's British Patent, and shows the substitution of a thin steel plate, attached to a frame, in front of the electro-magnet, for the membrane and iron armature. This form of instrument also embodies Reis's three principles—but with this improvement, the armature capable of inductive action, the elastic mounting, and the extended surface, are here all united in one organ, the thin flexible tympanum of steel. Apart from this unification of parts there is absolutely nothing in this form of Bell's receiver, that Reis did not invent fourteen years before. Bell's great and most signal improvement was not this beautiful mechanical modification of the Reis receiver, but lay in the entirely new suggestion to use such a receiver *as a transmitter* to work by magneto-electric induction. Two of Reis's receivers ([Fig. 21](#)) if coupled up with a battery will talk together as transmitter and receiver: but Reis did not know and never suggested this. Two of Yeates's receivers ([Fig. 42](#)) if coupled up with a battery will talk together as transmitter and receiver; but

Yeates did not know and never suggested this. Bell did discover this, and thereby invented a transmitter which, though now abandoned as a transmitter, for want of loudness, was more reliable than the anterior transmitters of Reis had been. He made another discovery, presently to be alluded to—that of putting a permanent magnet into the transmitter, to enable him to dispense with the battery; but beyond this and the other mechanical simplifications previously mentioned, all that he discovered may be summed up by saying that he found out that a receiver constructed on Reis's principles could work as a transmitter also. That was Bell's really great and important discovery which took all the world by storm at the Centennial Exhibition of 1876.

Bell subsequently added to his claims the substitution of a permanent magnet with an iron pole-piece, in place of the simple electro-magnet, thus enabling him to transmit his fluctuating currents without the trouble of using a battery, and the Bell transmitter, thus modified, is used to this day as a receiver, Reis had in his “knitting-needle” telephone, employed a permanent magnet of steel to serve as a receiver, he had not, however, applied it as Bell did to attract a plate of thin steel.

[Fig. 46](#), *K*, exhibits a form of electro-magnetic receiver described in Edison's British Specification, No. 2909, 1877, Fig. 24. This instrument, though patented seven months after Bell's instrument, differs from it in no point of importance. Its armature was a thin plate of iron, elastic, and having an extended surface; being, in fact, a tympanum.

No one can examine the set of receiving instruments collected in [Fig. 46](#) without being struck with the extraordinary similarity of design which pervades the entire series. In every one of the set there is an electro-magnet, the function of which is to set an armature^[52] into vibration by attracting it with a variable force. In every one the armature is of a material capable of magnetic induction; that is to say, iron, steel, or equivalent material. In every one of them the armature is either elastically mounted, or is in itself elastic. In every one of them (save only the two quite recent forms, *F* and *I*, which were intended not to speak, but to emit only one fixed musical note) there is an extended surface (either a sound-board or a tympanum) to communicate the vibrations to the air. Lastly, every one of these forms, when connected with the line through which the telephonic currents are being transmitted, is perfectly capable of reproducing articulate speech. But the inventor who had the genius to discover all these essential points, and to combine them in an instrument, and to use it to reproduce articulate speech,

is surely the true inventor of the system. The inventor of the system embodying these essential points was Philipp Reis.

APPENDIX IV.

ON THE DOCTRINE OF UNDULATORY CURRENTS.

“In this Specification the three words ‘oscillation,’ ‘vibration’ and ‘undulation,’ are used synonymously.”—Graham Bell, U.S. Patent, No. 174,465, filed Feb. 14, 1876.

In the preceding appendices it has been demonstrated that all that is essential in both transmitter and receiver of a Telephonic system was to be found existing in 1863 in the Telephone of Reis. There yet remains to be met the *doctrinaire* objection that as Reis never explicitly mentions an undulatory current as distinguished from an intermittent one, he never intended to use such a current. This objection is advanced only by those persons who have committed themselves to the idea that speech cannot be transmitted by a transmitter which opens and closes the circuit.

It is certain that Reis did not in any of his writings explicitly name an undulatory current: but it is equally certain that, whether he mentioned it or not, he both used one and intended to use one. He did not concern himself as to the precise manner in which the current fluctuated provided only he attained the end in view—namely, that the vibrations of the armature of the receiver should be similar to those of the transmitter. This he did lay down with great clearness and emphasis as his guiding principle; and he cared not about the intermediate question as to how the current did the work. He told the world that the electromagnet at the receiving end must be magnetised and demagnetised correspondingly with the vibrations imparted by the air to the tympanum of his transmitter, in order that the armature might be set into vibrations similar to those of the speaker’s voice. If the tympanum of the transmitter vibrated or oscillated or undulated—the terms are synonymous—so must the armature of the receiver. Graham Bell has told us precisely the same thing: “The current traversing the coils of the electromagnet *E* occasions an increase and diminution in its intensity” [that is to say, magnetises and demagnetises it], “and the armature *A*¹ is thrown into vibration” ... “and

thus imparts to the air at n^1 a facsimile copy of the motion of the air that acted upon the membrane n ." Bell agrees then absolutely in every detail with what Reis said on this point. That sound-waves should be transmitted by a Telephone requires indeed a process of several stages. (1.) The sound-waves must strike upon the tympanum of the transmitter and make it undulate, or, oscillate, or vibrate—whichever term you please—in a corresponding manner. (2.) The undulating tympanum must act upon the circuit, and either itself induce undulating or vibrating currents (Bell's plan, by magnetic induction), or else throw a current already flowing there, into undulations, or vibrations, or oscillations (Reis's plan, by varying contact-resistance), but in either case these undulations of the current must correspond to the original undulations of the air-waves. (3.) The undulating, or vibrating, or oscillating current must run round the coils of the electromagnet and cause its magnetic force to undulate, or oscillate, or vibrate by demagnetising it and then magnetising it, but this also must be in a manner corresponding to the original undulations. (4.) Further, the armature of the receiver must be set into undulations, or vibrations, or oscillations corresponding to those of the force of the electromagnet, and therefore to the undulations of the current that is magnetising and demagnetising it, and therefore identically corresponding with the original undulations of the sound-waves. (5.) The armature must communicate its vibrations to the air and to the ear of the listener. Of these successive stages Reis explicitly told the world that his instrument was to do the first one and the last three, and he several times emphasized the statement, that the final undulations of the last stage were to be similar to the original undulations of the first stage. The air at the listening end, the armature of the receiver, and the magnetism of the magnet, were all to be set by the fluctuations of the current into undulations corresponding with those of the tympanum at the speaker's end, and of the waves of his voice. It is perfectly clear therefore, that he regarded as self-evident the intermediate stage, and he did not dwell upon the necessity of the point, that his transmitting-current must also vibrate, because this was obviously so, and was only an intermediate matter of secondary moment. He chose rather to point out the necessity of unification between the first and last stages, leaving it to common sense to see that the "interruption" or the "opening and closing" of the circuit must be effected in a manner corresponding to the undulations of the impressed sound-wave. Had the "interruptions" not

been of the nature of corresponding variations of contact, the current could not have been set into corresponding vibrations, and the armature of the electromagnet could not have reproduced the vibrations of the transmitter. Clearly Reis's whole conception of telephony included as a minor and intermediate step the fact that the current was, by the action of the transmitter, caused to vary in strength in correspondence with the undulations of the tympanum—that, in fact, it was made to undulate by the action of the tympanum and of the interruptor which opened and closed the circuit in obedience to the undulations of the tympanum and in proportion to them.

A difficulty has been raised by telegraph operators that opening and closing the circuit means opening and closing the circuit in abrupt alternations of make-and-break. Reis never said so. Reis never used the phrase in this restricted and technical sense. He was not a professional telegraphist, and, as pointed out in Appendix I., he so arranged his contacts with the following springs and other contrivances, that the “opening and closing” of the circuit should not and could not be abrupt. A Reis transmitter is no more a “make-and-break” instrument than the Blake transmitter is. Both will give undulatory currents by opening and closing the circuit to a greater or less degree, if spoken gently to. Both will give abrupt makes-and-breaks of the circuit if shouted to, in spite of the following-springs, which are used to prevent abrupt interruptions. The term “opening and closing” which Reis applied to his transmitter, is used by him in exactly the same way as the phrase is used by engineers in describing the action of the governing throttle-valve of a steam-engine. The function of the governor, we are told in treatises on engineering, is to open and close the throttle-valve in a manner corresponding to the fall or rise of the governor-balls. No one in his senses imagines that the opening and closing action here referred to means an absolutely abrupt intermittence in the supply of steam. If the governor-balls rise a little by increase of speed, there is a corresponding closing, proportionate in amount to the amount of rise. If any person were to impress an oscillatory motion of rise and fall upon the governor, the supply of steam would be thrown into corresponding undulations. The matter stands precisely so with Reis's “interruptor” or “regulator;” it opens and closes the circuit in a manner corresponding with the undulations communicated to it. If it did not, it would violate the principle of correspondence so emphatically laid down by Reis.

It is, however, true that Reis's instruments, in spite of springs and adjusting screws, and other devices to prevent abrupt make-and-break occurring, were prone, by reason of the very lightness of the parts, to break contact, if too loudly spoken to. They share this fault with the more perfect transmitters of Blake and Berliner which are used to-day so generally. The undulatory currents of these transmitters are, like those of Reis's transmitters, liable to an occasional abrupt interruption, which, though it may not seriously affect the intelligibility of the words, does, to some extent, mar the perfection of the articulation. Still, in practice, to judge by the instruments used in the telephone exchanges of Great Britain, the Blake transmitter with its liability to make-and-brake abruptly is a more satisfactory instrument than the Bell transmitter, which is not used at all. Now the Bell transmitter working on the principle of which Bell is the first and undisputed inventor, is one in which the degree of contact in the circuit is never changed: for it works by the principle of "induction," whereby currents are set up in a circuit that is never opened or closed, either partially or wholly. Nevertheless the Blake transmitter, which opens and closes the circuit in proportion to the undulations of the tympanum, is the more satisfactory instrument for producing the undulating currents required to procure the all-essential correspondence between the undulations of the tympanum of the transmitter and those of the armature of the receiver. To sum the matter up, it appears that an instrument which opens and closes the circuit on Reis's principle of transmitting is in practice a more satisfactory transmitter of undulatory currents than Bell's transmitter which cannot open or close the circuit in the least. Reis, with his instruments, transmitted speech—as Herr Hold tells us (p. 126)—when the words spoken were not too loud. That is a proof that he did really use, whether he knew it or not, undulatory currents of electricity: and an undulatory current is none the less an undulatory current, even if occasionally abruptly interrupted. A speech is none the less a speech, even if the orator sneeze once or twice while speaking. Nay, we may go further, and say that an undulatory current is an undulatory current, even though the finer ripples of the waves are lost in transmission. This is what seems to have been the case with Reis's instruments as they were in 1861 and 1862. The consonants were satisfactorily transmitted, and so were all musical tones within the range of the instrument. But the finer ripples of the vowels were lost somehow in transmission. Reis, whose innate honour

and modesty led him always rather to understate than overstate the facts, most frankly acknowledged this, nay even invited attention to the fact, and discussed the imperfection from a high scientific standpoint. He proposed to rely for the correctness of his views upon the actual recorded curves of sound-waves, as taken down automatically by the then newly-invented phonautograph of Scott (see p. 60). It is perfectly marvellous how precise his views were upon the correspondence between the graphic curve or wave-form of a sound and the actual sound itself; a precision amply justified by the experience and the discoveries of the last ten years.

This matter of representing sounds—or rather the varying density of the air in the sound-wave—by a graphic curve, was a vital one to Reis. Had he had a less clear view of the nature of sound-waves than that afforded by a graphic *curve*, I doubt whether he would ever have grasped the problem of the telephone—that the final vibrations, or undulations, or oscillations of the armature in the receiver must *correspond with*—must be the very counterpart of—those of the tympanum of the transmitter. The clearness with which Reis saw this is only surpassed by the clearness with which he expressed himself upon it. For him a sound was simply a complicated series of variations in the density of the air, and capable, in all its complexity, of being represented by the rise and fall of an undulatory *curve*. “Every tone, and every combination of tones, evokes in our ear vibrations ... the motions of which may be represented by a *curve*” (p. 54). “That which is perceived by the auditory nerve ... *may be represented graphically according to its duration and magnitude by a curve*” ... (p. 53). “Our ear can perceive absolutely nothing more than is capable of being represented by *similar curves*” (p. 53). The curves with which he accompanied his original memoir—and now reproduced in facsimile, from Legat’s plates, at the end of this volume—are evidence of the thoroughness of his grasp on the undulatory principle. And he explicitly states this principle amongst “the various requisite conditions which must be fulfilled by the transmitting *and receiving* apparatus for the solution of the problem that has been set” (Legat’s Report, p. 71). He declared that so soon as it should become possible “at any place, and *in any prescribed manner*” (that is to say, whether by electric undulations or by mechanical undulations, as in the string of the toy telephone, or by any other means), “to set up vibrations whose *curves* are like those of any given tone or combination of tones,”

we should then receive the same impression as that tone or combination of tones would have produced upon us.

So much for Reis's principle of correspondence of undulations between the transmitter and the receiver; we have seen how clear and precise, yet how comprehensive it was, and how the general proposition necessarily included within itself, as an intermediate step, the particular minor proposition that the undulations of the current must also be in correspondence with the voice.

Keeping these points in mind, it is very remarkable that when Graham Bell, fourteen years later, followed Reis "into the field of telephonic research," he selected the very same method of expressing the relations between sounds and the undulations which corresponded with them. To show how remarkably in agreement the views of Reis and Bell are upon this question of representing by a curve the undulations which correspond to the voice, we select the following paragraphs and place them in parallel columns.

Reis.

Bell.

<p>That which is perceived by the auditory nerve ... may be represented graphically, according to its duration and magnitude by a curve.—(Memoir 'On Telephony' in the Jahresbericht of the Physical Society of Frankfurt-a.-M. 1860-61, p. 59.) [p. 53.]</p> <p>The height or depth of the sound produced ... depends upon the number of vibrations made in a given time.—(<i>Ib.</i> p. 63.) [p. 59.]</p>	<p>Electrical undulations, induced by a body capable of inductive action, can be represented graphically, without error by the same sinusoidal curve which expresses the vibration of the inducing body itself, and the effect of its vibration upon the air; for, as stated above, the rate of oscillation in the electrical current corresponds to the rate of vibration of the inducing body—that is, to the pitch of the sound produced.—(Specification of U. S. Patent No. 174,465, dated March 7, 1876.)</p>
--	--

The greater the condensation of the sound-conducting medium at any given moment, the greater will be the **amplitude** of vibration of the membrane.—(*Ib.* p. 58.) [p. 52.]

The intensity of the current varies with the **amplitude** of the vibration—that is, with the loudness of the sound;—(*Ib.*)

... each tone is dependent not only on the number of vibrations of the medium, but also on the **condensation or rarefaction** of the same.—(Legat’s Report, Zeitschrift des D.-Oesterr. Telegr. Vereins, 1863, p. 125.) [p. 77.]

and the polarity of the current corresponds to the direction of the vibrating body,—that is, to the **condensations and rarefactions** of air produced by the vibration.—(*Ib.*)

Let us exhibit the condensation curves for three tones—each singly (Plate I): then, by adding together the ordinates corresponding to equal abscissæ, we can determine new ordinates and develop a new curve which we may call the **combination-curve**. Now this gives us just exactly what our ear perceives from the **three simultaneous tones**.—(Memoir ‘On Telephony,’ p. 59.) [p. 54.]

The combined effect of A and B, when induced simultaneously on the same circuit, is expressed by the curve A + B, Fig. 4, which is the algebraical sum of the sinusoidal curves A and B. This curve A + B also indicates the actual motion of the air when **two musical notes** considered are sounded **simultaneously**.... (*Ib.*) The electrical movement, like the aerial motion, can be represented by a sinusoidal curve, or by the **resultant of several sinusoidal curves**.—(*Ib.*)

The very remarkable agreement of the preceding passages receives a most striking confirmation by comparing the curves respectively drawn by Reis and by Bell. These are facsimiled below, Reis’s “combination”-curve ([Fig. 47](#)) from Plate I. of his Memoir (also [Plate I.](#) of this volume),

and Bell's "resultant"-curve ([Fig. 48](#)) from Fig. 4 of his United States Patent Specification No. 174,465.

The most casual observer cannot fail to notice here that the three lines of undulatory curves of Bell's specification are practically identical with the three lower lines of undulatory curves of Reis's memoir. They are, moreover, in each case introduced for the sake of showing how a complex curve corresponds to a compound undulation.

Reis..

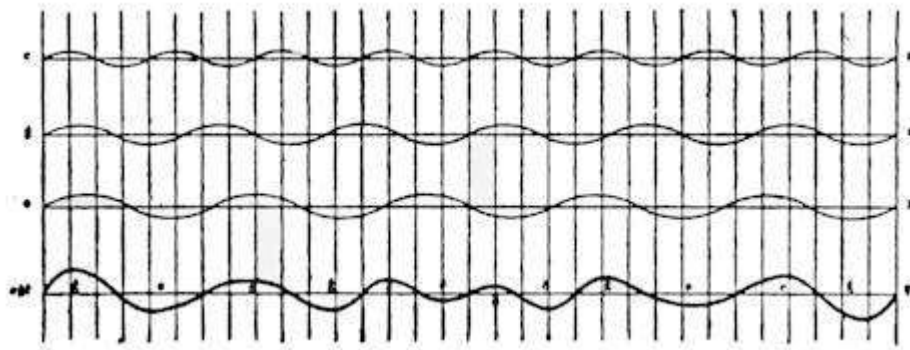

Fig. 47.

Bell..

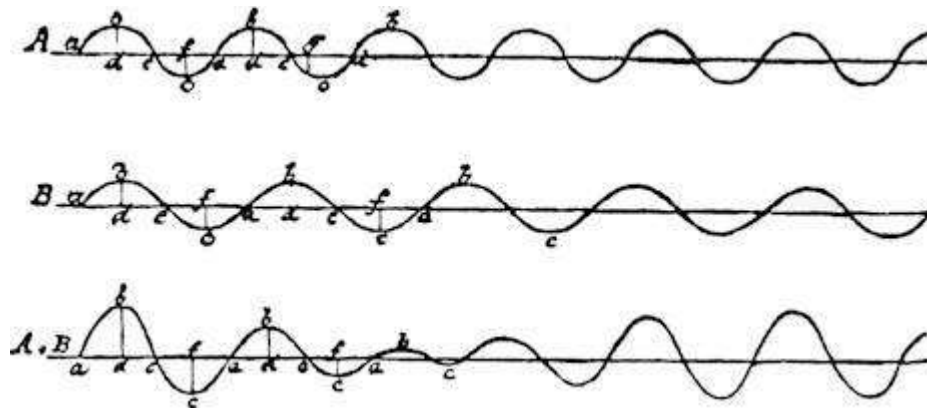

Fig. 48.

Far be it from me even to hint that either curve was plagiarised from the other. Bell tells us that his curve is to represent electrical oscillations, which, he adds, have the same curve as that both of the vibrating body and of the air. Reis tells us that his curve is to represent the oscillations of a tympanum, or of the air, or of the magnetisation of the magnet, or of the armature at the receiving end. How the magnetization of the electro-magnet was made to vary "correspondingly with the condensations and rarefactions of the air," as represented by such a curve, Reis did not

explicitly say, but left to the common sense of his readers to infer. Though the inference was obvious, Bell, who possibly had not then read Reis's researches, seized upon this intermediate stage of the process employed by Reis, and probably quite unconscious that Reis had already employed it, announced it as a discovery of his own; and then, losing sight of the point that all that was wanted was to secure correspondence between the initial and final stage, he magnified to an absurd and unwarranted importance this intermediate correspondence of the vibrations of the current with those of the tympanum, which correspondence any one reading Reis's papers would know at once Reis had implicitly assumed and actually employed when he transmitted articulate speech.

If we pass from the method of graphically representing undulations by curves, and proceed to compare the language in which Reis described the action of his machine in reproducing the undulations imparted to the transmitter, with that in which Graham Bell described the action of his machine some fourteen years later, we shall find^[53] an agreement even more precise.

Reis.

Bell.

The **electromagnet** ... will be demagnetised and magnetised correspondingly with the condensations and rarefactions of the mass of air, ... and **the armature ... will be set into vibrations** similar to those of the **membrane** in the transmitting apparatus.—(Legat's Report, *Zeitschrift*, p. 128, 1862.) [p. 77.]

The current traversing the coils of the **electromagnet E**, occasions an increase and diminution in its intensity, and **the armature A¹ is thrown into vibrations** ... and thus imparts to the air at n^1 a **facsimile** copy of the motion of the air that acted upon the **membrane n**.—(Specification of British Patent, No. 4765, Dec. 9th, 1876, p. 17.)

The transmitter, Fig. A, consists of a **A cone A** is used to converge sound **conical tube** ... closed by a vibrations upon the **membrane**.

membrane ... by speaking ... into the tube ... there will be evoked a motion of the **membrane** ... (*op. cit.*)

When a sound is uttered in the cone the **membrane** *a* is set in vibration....

The apparatus ... offers the possibility of **creating these vibrations** in every fashion that may be desired, and the employment of electro-galvanism gives us the possibility of calling into life, at any given distance, **vibrations similar to the vibrations** that have been produced, and in this way to reproduce at any place the tones that have been originated at another place.— (*Legat's Report, op. cit.*)

... and thus electrical **undulations are created** upon the circuit *E b e f g*... The undulatory current passing through the electromagnet *f* influences its armature *h* to copy the motion of the armature *c*... These **undulations are similar in form to the air undulations caused by the sound.**

>As soon therefore as it shall be possible ... to set up vibrations whose **curves are like** those of any given tone or combination of tones, we shall receive the same impression as that tone or combination of tones would have produced upon us.—(*Memoir 'On Telephony,' p. 60.*) [p. 55.]

—that is, they are represented graphically by **similar curves**....

A similar sound to that uttered into *A* is then heard to proceed from *I*.— (*Specification of U. S. Patent, No. 174,465.*)

Any sound will be reproduced, if strong enough to set the membrane in motion.—(*Letter to Mr. Ladd, 1863.*) [p. 84.]

There are many other uses to which these instruments may be put, such as ... the telegraphic transmission of noises or **sounds of any kind**.— (*Ib.*)

<p>the armature belonging to the magnet will be set into vibrations similar to those of the membrane in the transmitting apparatus.— (Legat’s Report, 1862.) [p. 77.]</p>	<p>I would have it understood that what I claim is:—... Tenth. In a system of electric telegraph or telephony consisting of transmitting and receiving instruments united upon an electric circuit, I claim the production in the armature of each receiving instrument of any given motion by subjecting said armature to an attraction varying in intensity, however such variation may be produced in the magnet, and hence I claim the production of any given sound or sounds from the armature of the receiving instrument by subjecting said armature to an attraction varying in intensity in such manner as to throw the armature into that form of vibration that characterizes the given sound or sounds.—(Specification of British Patent, No. 4765, Dec. 9, 1876.)</p>
---	---

One cannot help thinking that some claims to great inventions are just a little “too previous.”

If it should still be said that Reis’s method of transmitting speech, whether it did its work by undulatory currents or no, was avowedly *imperfect*, and that therefore such a claim as that quoted above is justified by the subsequent invention of an instrument the articulation of which was more reliable, let us compare what each inventor has said about the imperfections^[54] of his own instrument.

Reis.

Bell.

That which has here been spoken of will still require considerable improvement, and in particular mechanical science must complete the apparatus to be used.—(Legat’s Report, 1862.) [p. 78.]

It is a mistake, however, to suppose that the articulation was by any means perfect.... Still the articulation was there, and I recognized the fact that the indistinctness was entirely due to the imperfection of the instrument.—(‘Researches in Telephony,’ Journal of Soc. of Telegr. Engineers, Dec. 1877.)

If it should be said that Bell is here speaking only of an early and experimental form, and not of his real invention, it should be remembered that Bell here refers to the apparatus with cone and membrane, identical with that exhibited at Glasgow in September, 1876, by Sir William Thomson (who had received it from Bell) and by him described as the very “hardihood of invention,” and “by far the greatest of all the marvels of the electric telegraph.” It certainly worked upon the principle of undulatory currents,^[55] whether it articulated or not. Bell had himself, speaking in May 1876, before the American Academy of Arts and Sciences upon his researches, even more explicitly admitted the imperfections of his own instrument.

The effects were not sufficiently distinct to admit of sustained conversation through the wire. Indeed, as a general rule, **the articulation was unintelligible**, excepting when familiar sentences were employed.—(Proceedings of American Academy of Arts and Sciences, vol. xii. p. 7.)

Yet this most imperfect machine, of which the articulation was, as a general rule, unintelligible, had, two months previously, had a patent

granted to it as a new invention, the claim being for “the method of, and apparatus for, transmitting vocal or other sounds telegraphically, as herein described, by causing electrical undulations similar in form to the vibrations of the air accompanying the said vocal or other sounds, substantially as set forth.”

If then mere mechanical imperfections do not make an invention any the less a true invention capable of legal recognition, it would be dishonest to the last degree to deny to Philipp Reis the honour of his invention, of which he honestly and openly stated both the successes and the imperfections. He told the world what he aimed at, and in what measure success had crowned his aims. His claim to be the inventor of the Telephone he considered to be justified by that measure of success. If he was so far in advance of his time that the world was unprepared to receive or use the splendid discovery which he gave freely to it, that was not his fault; nor does neglect or apathy make him in one single degree the less entitled to the credit of his inventions. *Tulit alter honores* has not unfrequently been truly said concerning the men of genius who have had the misfortune to live in advance of the age.

But posterity does not let the names of such truly great ones perish in the dust. The inventor of the Telephone will be remembered and honoured in the coming if not in the present age.

SCHEDULE OF AUTHORITIES

KEY TO TITLE OF WORK

- A. ‘Jahresbericht des Physikalischen Vereins zu Frankfurt-am-Main’
- B. ‘Fortschritte der Physik’ (Krönig and Beetz)
- C. Dingler’s ‘Polytechnisches Journal’
- D. ‘Polytechnisches Central-Blatt’(Schnedermann and Böttcher)

- E. Böttger's 'Polytechnisches Notizblatt'
- F. 'Didaskalia'
- G. 'Zeitschrift des Deutsch-Oesterreichischen Telegraphen Vereins'
(Dr. Brix)
- H. Kuhn's 'Handbuch der angewandten Elektrizitätslehre'
- I. Pisko's 'Die Neueren Apparate der Akustik'
- J. (Pisko's) 'Hessler's Lehrbuch der Technischen Physik'
- K. Müller Pouillet's 'Lehrbuch der Physik'

Title of Work.	Place of Issue.	Date.	Volume and Page.	British Museum.
A.	Frankfurt-a.-M.	{1860-1 {1863	p. 57 p. 129	} Ac. 4428
B.	Berlin	{1861 {1863	xvii. p. 171-173 ——? p. 96	} Ac. 3775
C.	Stuttgart	1863	{clxviii. p. 185-187 } {clxix. p. 23 }	Pp. 1780

			{clxix. p. 399 }	
D.	Cassel	1863	xxix. p. 858	Pp. 1615 b.
E.	Mainz	1863	{No. 6 {No. 15 }	Pp. 1787
F.	Frankfurt-a.- M.	1862	May 8, May 14	..
G.	Berlin	1862	ix. p. 125	..
H.	Leipzig	1866	p. 1017-1021	2244 i
I.	Vienna	1865	{p. 94-103 {p. 241-243 }	8705 cc.
J.	Vienna	1866	Vol. I. p. 648	..
K.	Brunswick	1868	Vol. II. p. 386-388	..

KEY TO TABLE OF REFERENCES

R.S. Royal Society.

R.L.

Ronald's Library.

I.C.E. Institution Civil
Engineers.

R.I. Royal Institution.

G.S.P.O. Great Seal Patent
Office.

S.M. School of Mines.

U.C.L. University College,
London.

B.L.O. Bodleian Library, Oxford.

K.C. King's College.

O.U.M.L. Oxford University
Museum Library.

For "Title of Work" see keys in previous table.

AND REFERENCES.

Title of Work.	R.S.	R.L.	I.C.E.	R.I.	G.S.P.O.	S.M.	U.C.L.	B.L.O.	K.C.	O.U.M.L.
A.	1846-1860
B.	✓	..	✓	✓	6546, 118 E	✓	✓	..	✓	✓

C.	✓	..	✓	✓	1296, 94 A	✓
D.	1132, 94 I
E.
F.
G.	✓	..	9511, 24 E
H.	..	✓	..	✓	13146, 163 C	198 e 133
I.	✓	✓
J.	..	✓
K.	A newer edition (1872)	..	✓	(Ed. 1876)	✓

ADDITIONAL PREFERENCES CONCERNING REIS'S TELEPHONE.

Schenk's *Philipp Reis, der Erfinder des Telephons*, 1878.

Sack's *Die Entwicklung der elektrischen Telephonie*, 1878.

Ferguson's *Electricity* (Ed. 1867), p. 257.

Wiedemann's *Galvanismus* (1874), Vol. ii. p. 598.

Gartenlaube, die; for 1863, No. 51, p. 807-809.

Aus der Natur; for 1862, xxi. p. 470-474.

Cosmos, Vol. xxiv. p. 349 (1864).

Proc. Lit. Phil. Soc. Manchester (1865), Nov. 10, 1864.

Rep. Brit. Assoc. (1863), p. 19.

Die Geschichte und Entwicklung des elektrischen Fernsprechwesens, 1880. (Officially issued from the Imperial German Post-Office, Berlin.)

LONDON: PRINTED BY WILLIAM CLOWES AND SONS,
LIMITED, STAMFORD STREET AND CHARING CROSS.

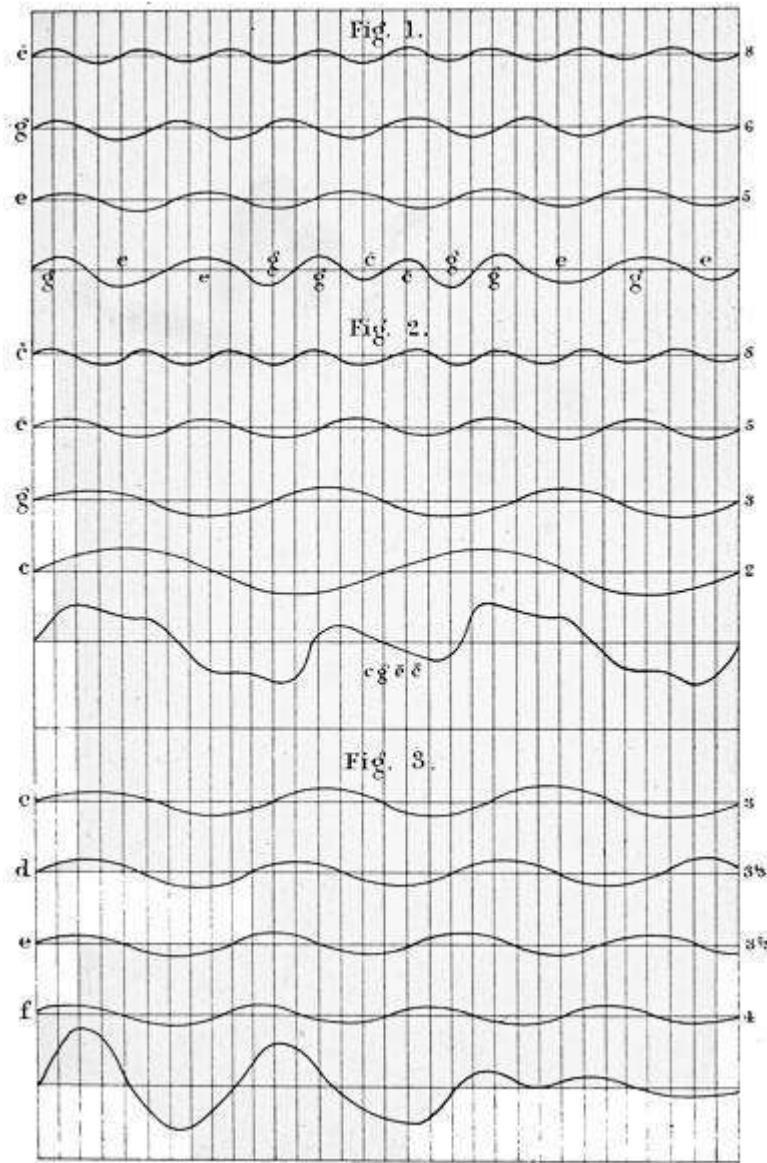
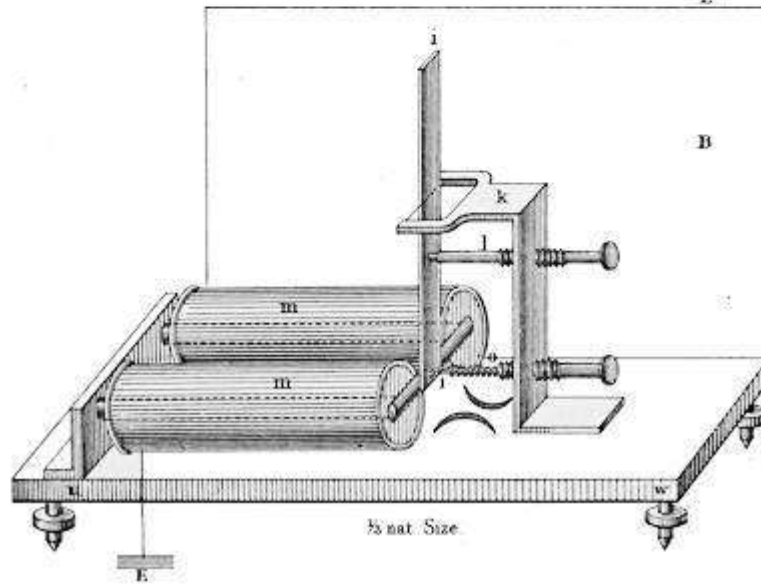
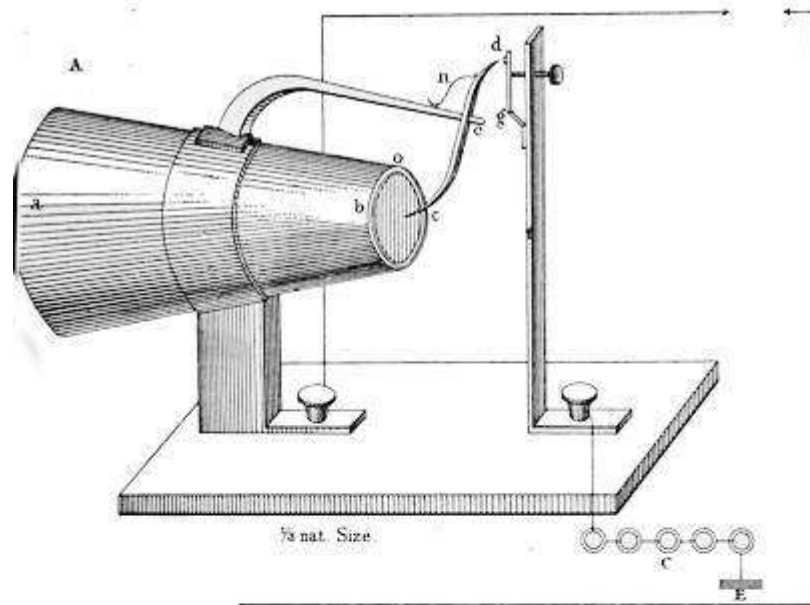

Plate 1.
REPRODUCTION OF TONES IN THE
ELECTRO-GALVANIC WAY.

THO^s. KELL & SON. LITH 40, KING S^t. COVENT GARDEN



**REPRODUCTION OF TONES IN THE
ELECTRO-GALVANIC WAY.**

THO^S. KELL & SON. LITH 40, KING S^t. COVENT GARDEN

**BOOKS RELATING
TO
APPLIED SCIENCE
PUBLISHED BY
E. & F. N. SPON,
LONDON: 16, CHARING CROSS.
NEW YORK: 44, MURRAY STREET.**

A Pocket-Book for Chemists, Chemical Manufacturers, Metallurgists, Dyers, Distillers, Brewers, Sugar Refiners, Photographers, Students, etc., etc. By THOMAS BAYLEY, Assoc. R.C. Sc. Ireland, Analytical and Consulting Chemist and Assayer. Second edition, with additions, 437 pp., royal 32mo, roan, gilt edges, 5s.

SYNOPSIS OF CONTENTS:

Atomic Weights and Factors—Useful Data—Chemical Calculations—Rules for Indirect Analysis—Weights and Measures—Thermometers and Barometers—Chemical Physics—Boiling Points, etc.—Solubility of Substances—Methods of Obtaining Specific Gravity—Conversion of Hydrometers—Strength of Solutions by Specific Gravity—Analysis—Gas Analysis—Water Analysis—Qualitative Analysis and Reactions—Volumetric Analysis—Manipulation—Mineralogy—Assaying—Alcohol—Beer—Sugar—Miscellaneous Technological matter relating to Potash, Soda, Sulphuric Acid, Chlorine, Tar Products, Petroleum, Milk, Tallow, Photography, Prices, Wages, Appendix, etc., etc.

The Mechanician: A Treatise on the Construction and Manipulation of Tools, for the use and instruction of Young Engineers and Scientific

Amateurs, comprising the Arts of Blacksmithing and Forging; the Construction and Manufacture of Hand Tools, and the various Methods of Using and Grinding them; the Construction of Machine Tools, and how to work them; Machine Fitting and Erection; description of Hand and Machine Processes; Turning and Screw Cutting; principles of Constructing and details of Making and Erecting Steam Engines, and the various details of setting out work, etc., etc. By CAMERON KNIGHT, Engineer. *Containing 1147 illustrations*, and 397 pages of letter-press. Third edition, 4to, cloth, 18s.

On Designing Belt Gearing. By E. J. COWLING WELCH, Mem. Inst. Mech. Engineers, Author of 'Designing Valve Gearing.' Fcap. 8vo, sewed, 6d.

A Handbook of Formulæ, Tables, and Memoranda, for Architectural Surveyors and others engaged in Building. By J. T. HURST, C.E. Thirteenth edition, royal 32mo, roan, 5s.

“It is no disparagement to the many excellent publications we refer to, to say that in our opinion this little pocket-book of Hurst’s is the very best of them all, without any exception. It would be useless to attempt a recapitulation of the contents, for it appears to contain almost *everything* that anyone connected with building could require, and, best of all, made up in a compact form for carrying in the pocket, measuring only 5 in. by 3 in., and about $\frac{3}{4}$ in. thick, in a limp cover. We congratulate the author on the success of his laborious and practically compiled little book, which has received unqualified and deserved praise from every professional person to whom we have shown it.”—*The Dublin Builder.*

The Cabinet Maker; being a Collection of the most approved designs in the Mediæval, Louis-Seize, and Old English styles, for the use of Cabinet Makers, Carvers, &c. By R. CHARLES. 96 *plates*, folio, half-bound, 10s. 6d.

Quantity Surveying. By J. LEANING. With 42 illustrations, crown 8vo, cloth, 9s.

Contents:

A complete Explanation of the London Practice.
General Instructions.
Order of Taking Off.
Modes of Measurement of the various Trades.
Use and Waste.
Ventilation and Warming.
Credits, with various Examples of Treatment.
Abbreviations.
Squaring the Dimensions.
Abstracting, with Examples in illustration of each Trade.
Billing.
Examples of Preambles to each Trade.
Form for a Bill of Quantities.
 Do. Bill of Credits.
 Do. Bill for Alternative Estimate.
Restorations and Repairs, and Form of Bill.
Variations before Acceptance of Tender.
Errors in a Builder's Estimate.
Schedule of Prices.
Form of Schedule of Prices.
Analysis of Schedule of Prices.
Adjustment of Accounts.
Form of a Bill of Variations.
Remarks on Specifications.
Prices and Valuation of Work, with Examples and Remarks upon
each Trade.
 The Law as it affects Quantity Surveyors, with Law Reports.
 Taking Off after the Old Method.
 Northern Practice.
 The General Statement of the Methods recommended by the
Manchester Society of Architects for taking Quantities.
 Examples of Collections.
 Examples of "Taking Off" in each Trade.
 Remarks on the Past and Present Methods of Estimating.

A Practical Treatise on Heat, as applied to the Useful Arts; for the Use of Engineers, Architects, &c. By THOMAS BOX. *With 14 plates.* Third edition, crown 8vo, cloth, 12s. 6d.

A Descriptive Treatise on Mathematical Drawing Instruments: their construction, uses, qualities, selection, preservation, and suggestions for improvements, with hints upon Drawing and Colouring. By W. F. STANLEY, M. R. I. Fifth edition, *with numerous illustrations*, crown 8vo, cloth, 5s.

Spons' Architects' and Builders' Pocket-Book of Prices and Memoranda. Edited by W. YOUNG, Architect. Royal 32mo, roan, 4s. 6d.; or cloth, red edges, 3s. 6d. *Published annually.* Tenth edition. *Now ready.*

Long-Span Railway Bridges, comprising Investigations of the Comparative Theoretical and Practical Advantages of the various adopted or proposed Type Systems of Construction, with numerous Formulæ and Tables giving the weight of Iron or Steel required in Bridges from 300 feet to the limiting Spans; to which are added similar Investigations and Tables relating to Short-span Railway Bridges. Second and revised edition. By B. BAKER, Assoc. Inst. C.E. *Plates*, crown 8vo, cloth, 5s.

Elementary Theory and Calculation of Iron Bridges and Roofs. By AUGUST RITTER, Ph.D., Professor at the Polytechnic School at Aix-la-Chapelle. Translated from the third German edition, by H. R. SANKEY, Capt. R.E. With 500 *illustrations*, 8vo, cloth, 15s.

The Builder's Clerk: a Guide to the Management of a Builder's Business. By THOMAS BALES. Fcap. 8vo, cloth, 1s. 6d.

The Elementary Principles of Carpentry. By THOMAS TREDGOLD. Revised from the original edition, and partly re-written, by JOHN THOMAS HURST. Contained in 517 pages of letter-press, and *illustrated* with 48 *plates* and 150 *wood engravings*. Third edition, crown 8vo, cloth, 18s.

Section I. On the Equality and Distribution of Forces—Section II. Resistance of Timber—Section III. Construction of Floors—Section IV. Construction of Roofs—Section V. Construction of Domes and Cupolas—Section VI. Construction of Partitions—Section VII. Scaffolds, Staging, and Gantries—Section VIII. Construction of Centres for Bridges—Section IX. Cofferdams, Shoring, and Strutting—Section X. Wooden Bridges and Viaducts—Section XI. Joints, Straps, and other Fastenings—Section XII. Timber.

Our Factories, Workshops, and Warehouses: their Sanitary and Fire-Resisting Arrangements. By B. H. THWAITE, Assoc. Mem. Inst. C.E. *With 183 wood engravings*, crown 8vo, cloth, 9s.

Gold: Its Occurrence and Extraction, embracing the Geographical and Geological Distribution and the Mineralogical Characters of Gold-bearing rocks; the peculiar features and modes of working Shallow Placers, Rivers, and Deep Leads; Hydraulicing; the Reduction and Separation of Auriferous Quartz; the treatment of complex Auriferous ores containing other metals; a Bibliography of the subject and a Glossary of Technical and Foreign Terms. By ALFRED G. LOCK, F.R.G.S. *With numerous illustrations and maps*, 1250 pp., super-royal 8vo, cloth, 2l. 12s. 6d.

Progressive Lessons in Applied Science. By EDWARD SANG, F.R.S.E. Crown 8vo, cloth, each Part, 3s.

Part 1. Geometry on Paper—Part 2. Solidity, Weight, and Pressure—Part 3. Trigonometry, Vision, and Surveying Instruments.

A Practical Treatise on Coal Mining. By GEORGE G. ANDRÉ, F.G.S., Assoc. Inst. C.E., Member of the Society of Engineers. *With 82 lithographic plates.* 2 vols., royal 4to, cloth, 3l. 12s.

Sugar Growing and Refining: a Comprehensive Treatise on the Culture of Sugar-yielding Plants, and the Manufacture, Refining, and Analysis of Cane, Beet, Maple, Milk, Palm, Sorghum, and Starch Sugars, with copious statistics of their production and commerce, and a chapter on the distillation of Rum. By CHARLES G. WARNFORD LOCK, F.L.S., &c., and G. W. WIGNER and R. H. HARLAND, FF.C.S., FF.I.C. *With 205 illustrations*, 8vo, cloth, 30s.

Spons' Information for Colonial Engineers. Edited by J. T. HURST. Demy 8vo, sewed.

No. 1. Ceylon. By ABRAHAM DEANE, C.E. 2s. 6d.

CONTENTS:

Introductory Remarks—Natural Productions—Architecture and Engineering—Topography, Trade, and Natural History—Principal Stations—Weights and Measures, etc., etc.

No. 2. Southern Africa, including the Cape Colony, Natal, and the Dutch Republics. By Henry Hall, F.R.G.S., F.R.C.I. With Map. 3s. 6d.

CONTENTS:

General Description of South Africa—Physical Geography with reference to Engineering Operations—Notes on Labour and Material in Cape Colony—Geological Notes on Rock Formation in South Africa—Engineering Instruments for Use in South Africa—Principal Public Works in Cape Colony: Railways, Mountain Roads and Passes, Harbour Works, Bridges, Gas Works, Irrigation and Water Supply, Lighthouses, Drainage and Sanitary Engineering, Public Buildings, Mines—Table of Woods in South Africa—Animals used for Draught Purposes—Statistical Notes—Table of Distances—Rates of Carriage, etc.

No. 3. India. By F. C. DANVERS, Assoc. Inst. C.E. With Map. 4s. 6d.

CONTENTS:

Physical Geography of India—Building Materials—Roads—Railways—Bridges—Irrigation—River Works—Harbours—Lighthouse Buildings—Native Labour—The Principal Trees of India—Money—Weights and Measures—Glossary of Indian Terms, etc.

A Practical Treatise on Casting and Founding, including descriptions of the modern machinery employed in the art. By N. E. SPRETSON, Engineer. Third edition, with 82 *plates* drawn to scale, 412 pp., demy 8vo, cloth, 18s.

The Clerk of Works: a Vade-Mecum for all engaged in the Superintendence of Building Operations. By G. G. HOSKINS, F.R.I.B.A. Third edition, fcap. 8vo, cloth, 1s. 6d.

Tropical Agriculture; or, the Culture, Preparation, Commerce, and Consumption of the Principal Products of the Vegetable Kingdom, as furnishing Food, Clothing, Medicine, etc., and in their relation to the Arts and Manufactures; forming a practical treatise and Handbook of Reference for the Colonist, Manufacturer, Merchant, and Consumer, on

the Cultivation, Preparation for Shipment, and Commercial Value, etc., of the various Substances obtained from Trees and Plants entering into the Husbandry of Tropical and Sub-Tropical Regions. By P. L. SIMMONDS. Second edition, revised and improved, 515 pages, 8vo, cloth, 1l. 1s.

Steel: its History, Manufacture, and Uses. By J. S. JEANS, Secretary of the Iron and Steel Institute. 860 pages and 24 plates, 8vo, cloth, 36s.

American Foundry Practice: Treating of Loam, Dry Sand, and Green Sand Moulding, and containing a Practical Treatise upon the Management of Cupolas, and the Melting of Iron. By T. D. WEST, Practical Iron Moulder and Foundry Foreman. Second edition, with numerous illustrations, crown 8vo, cloth, 10s. 6d.

The Maintenance of Macadamised Roads. By T. CODRINGTON, M.I.C.E., F.G.S., General Superintendent of County Roads for South Wales. 8vo, cloth, 6s.

Hydraulic Steam and Hand Power Lifting and Pressing Machinery. By FREDERICK COLYER, M. Inst. C.E., M. Inst. M.E. With 73 plates, 8vo, cloth, 18s.

Pumps and Pumping Machinery. By F. COLYER, M.I.C.E., M.I.M.E. With 23 folding plates, 8vo, cloth, 12s. 6d.

Tables of the Principal Speeds occurring in Mechanical Engineering, expressed in metres in a second. By P. KEERAYEFF, Chief Mechanic of the Obouchoff Steel Works, St. Petersburg; translated by SERGIUS KERN, M.E. Fcap. 8vo, sewed, 6d.

Girder Making and the Practice of Bridge Building in Wrought Iron, illustrated by Examples of Bridges, Piers, and Girder Work, etc., constructed at the Skerne Iron Works, Darlington, by EDWARD HUTCHINSON, M. Inst. M.E. With 35 plates, demy 8vo, cloth, 10s. 6d.

Spons' Dictionary of Engineering, Civil, Mechanical, Military, and Naval; with technical terms in French, German, Italian, and Spanish, 3100 pp., and nearly 8000 engravings, in super-royal 8vo, in 8 divisions, 5l. 8s. Complete in 3 vols., cloth, 5l. 5s. Bound in a superior manner, half-morocco, top edge gilt, 3 vols., 6l. 12s.

See page 15.

A Treatise on the Origin, Progress, Prevention, and Cure of Dry Rot in Timber; with Remarks on the Means of Preserving Wood from Destruction by Sea-Worms, Beetles, Ants, etc. By THOMAS ALLEN BRITTON, late Surveyor to the Metropolitan Board of Works, etc., etc. *With 10 plates*, crown 8vo, cloth, 7s. 6d.

Metrical Tables. By G. L. MOLESWORTH, M.I.C.E. 32mo, cloth, 1s. 6d.

CONTENTS.

General—Linear Measures—Square Measures—Cubic
Measures—Measures of Capacity—Weights—Combinations—
Thermometers.

A Handbook of Electrical Testing. By H. R. KEMPE, Member of the Society of Telegraph Engineers. New edition, revised and enlarged, *with 81 illustrations*. Crown 8vo, cloth, 12s. 6d.

Electro-Telegraphy. By FREDERICK S. BEECHEY, Telegraph Engineer. A Book for Beginners. *Illustrated*. Fcap. 8vo, sewed, 6d.

Handrailing: by the Square Cut. By JOHN JONES, Staircase Builder. Fourth edition, *with seven plates*, 8vo, cloth, 3s. 6d.

Handrailing: by the Square Cut. By JOHN JONES, Staircase Builder. Part Second, *with eight plates*, 8vo, cloth, 3s. 6d.

The Gas Consumer's Handy Book. By WILLIAM RICHARDS, C.E. *Illustrated*. 18mo, sewed, 6d.

Steam Pleating for Buildings; or, Hints to Steam Fitters, being a description of Steam Heating Apparatus for Warming and Ventilating Private Houses and large Buildings; with Remarks on Steam, Water, and Air in their relation to Heating; to which are added miscellaneous Tables. By J. W. BALDWIN, Steam Heating Engineer. *With many illustrations*. Second edition, crown 8vo, cloth, 10s. 6d.

A Pocket-Book of Useful Formulæ and Memoranda for Civil and Mechanical Engineers. By GUILFORD L. MOLESWORTH, Mem. Inst. C.E., Consulting Engineer to the Government of India for State Railways. *With numerous illustrations*, 744 pp. Twenty-first edition, revised and enlarged, 32mo, roan, 6s.

SYNOPSIS OF CONTENTS:

Surveying, Levelling, etc.—Strength and Weight of Materials—Earthwork, Brickwork, Masonry, Arches, etc.—Struts, Columns, Beams, and Trusses—Flooring, Roofing, and Roof Trusses—Girders, Bridges, etc.—Railways and Roads—Hydraulic Formulæ—Canals, Sewers, Waterworks, Docks—Irrigation and Breakwaters—Gas, Ventilation, and Warming—Heat, Light, Colour, and Sound—Gravity: Centres, Forces, and Powers—Millwork, Teeth of Wheels, Shafting, etc.—Workshop Recipes—Sundry Machinery—Animal Power—Steam and the Steam Engine—Water-power, Water-wheels, Turbines, etc.—Wind and Windmills—Steam Navigation, Ship Building, Tonnage, etc.—Gunnery, Projectiles, etc.—Weights, Measures, and Money—Trigonometry, Conic Sections, and Curves—Telegraphy—Mensuration—Tables of Areas and Circumference, and Arcs of Circles—Logarithms, Square and Cube Roots, Powers—Reciprocals, etc.—Useful Numbers—Differential and Integral Calculus—Algebraic Signs—Telegraphic Construction and Formulæ.

Spons' Tables and Memoranda for Engineers; selected and arranged by J. T. HURST, C.E., Author of 'Architectural Surveyors' Handbook,' 'Hurst's Tredgold's Carpentry,' etc. Fifth edition, 64mo, roan, gilt edges, 1s.; or in cloth case, 1s. 6d.

This work is printed in a pearl type, and is so small, measuring only 2½ in. by 1¾ in. by ¼ in. thick, that it may be easily carried in the waistcoat pocket.

“It is certainly an extremely rare thing for a reviewer to be called upon to notice a volume measuring but 2½ in. by 1¾ in., yet these dimensions faithfully represent the size of the handy little book before us. The volume—which contains 118 printed pages, besides a few blank pages for memoranda—is, in fact, a true pocket-book, adapted for being carried in the waistcoat pocket, and containing a far greater amount and variety of information than most people would imagine could be compressed into so small a space.... The little volume has been compiled with considerable

care and judgment, and we can cordially recommend it to our readers as a useful little pocket companion.”—*Engineering*.

Analysis, Technical Valuation, Purification and Use of Coal Gas. By the Rev. W. R. BOWDITCH, M.A. *With wood engravings*, 8vo, cloth, 12s. 6d.

Condensation of Gas—Purification of Gas—Light—Measuring—Place of Testing Gas—Test Candles—The Standard for Measuring Gas-light—Test Burners—Testing Gas for Sulphur—Testing Gas for Ammonia—Condensation by Bromine—Gravimetric Method of taking Specific Gravity of Gas—Carbureting or Naphthalizing Gas—Acetylene—Explosions of Gas—Gnawing of Gaspipes by Rats—Pressure as related to Public Lighting, etc.

A Practical Treatise on Natural and Artificial Concrete, its Varieties and Constructive Adaptations. By HENRY REID, Author of the ‘Science and Art of the Manufacture of Portland Cement.’ New Edition, *with 59 woodcuts and 5 plates*, 8vo, cloth, 15s.

Hydrodynamics: Treatise relative to the Testing of Water-Wheels and Machinery, with various other matters pertaining to Hydrodynamics. By JAMES EMERSON. *With numerous illustrations*, 360 pp. Third edition, crown 8vo, cloth, 4s. 6d.

The Gas Analyst’s Manual. By F. W. HARTLEY, Assoc. Inst. C.E., etc. *With numerous illustrations.* Crown 8vo, cloth, 6s.

Gas Measurement and Gas Meter Testing. By F. W. HARTLEY. Fourth edition, revised and extended. *Illustrated*, crown 8vo, cloth, 4s.

The French-Polishers Manual. By a French-Polisher; containing Timber Staining, Washing, Matching, Improving, Painting, Imitations, Directions for Staining, Sizing, Embodying, Smoothing, Spirit Varnishing, French-Polishing, Directions for Repolishing. Third edition, royal 32mo, sewed, 6d.

Hops, their Cultivation, Commerce, and Uses in various Countries. By P. L. SIMMONDS, Crown 8vo, cloth, 4s. 6d.

A Practical Treatise on the Manufacture and Distribution of Coal Gas. By WILLIAM RICHARDS. Demy 4to, with numerous wood engravings and 29 plates, cloth, 28s.

SYNOPSIS OF CONTENTS:

Introduction—History of Gas Lighting—Chemistry of Gas Manufacture, by Lewis Thompson, Esq., M.R.C.S.—Coal, with Analyses, by J. Paterson, Lewis Thompson, and G. R. Hislop. Esqrs.—Retorts, Iron and Clay—Retort Setting—Hydraulic Main—Condensers—Exhausters—Washers and Scrubbers—Purifiers—Purification—History of Gas Holder—Tanks, Brick and Stone, Composite, Concrete, Cast-iron, Compound Annular Wrought-iron—Specifications—Gas Holders—Station Meter—Governor—Distribution—Mains—Gas Mathematics, or Formulæ for the Distribution of Gas, by Lewis Thompson, Esq.—Services—Consumers' Meters—Regulators—Burners—Fittings—Photometer—Carburization of Gas—Air Gas and Water Gas—Composition of Coal Gas, by Lewis Thompson, Esq.—Analyses of Gas—Influence of Atmospheric Pressure and Temperature on Gas—Residual Products—Appendix—Description of Retort Settings, Buildings, etc., etc.

Practical Geometry and Engineering Drawing; a Course of Descriptive Geometry adapted to the Requirements of the Engineering Draughtsman, including the determination of cast shadows and Isometric Projection, each chapter being followed by numerous examples; to which are added rules for Shading, Shade-lining, etc., together with practical instructions as to the Lining, Colouring, Printing, and general treatment of Engineering Drawings, with a chapter on drawing Instruments. By GEORGE S. CLARKE, Lieut. R.E., Instructor in Mechanical Drawing, Royal Indian Engineering College. 20 plates, 4to, cloth, 15s.

The Elements of Graphic Statics. By PROFESSOR KARL VON OTT, translated from the German by G. S. CLARKE, Lieut. R.E., Instructor in Mechanical Drawing, Royal Indian Engineering College. With 93 illustrations, crown 8vo, cloth, 5s.

The Principles of Graphic Statics. By GEORGE SYDENHAM CLARKE, Lieut. Royal Engineers. With 112 illustrations. 4to. cloth, 12s. 6d.

The New Formula for Mean Velocity of Discharge of Rivers and Canals. By W. R. KUTTER. Translated from articles in the 'Cultur-Ingenieur,' by LOWIS D'A. JACKSON, Assoc. Inst. C.E. 8vo, cloth, 12s. 6d.

Practical Hydraulics; a Series of Rules and Tables for the use of Engineers, etc., etc. By THOMAS BOX. Fifth edition, *numerous plates*, post 8vo, cloth, 5s.

A Practical Treatise on the Construction of Horizontal and Vertical Waterwheels, specially designed for the use of operative mechanics. By WILLIAM CULLEN, Millwright and Engineer. *With 11 plates*. Second edition, revised and enlarged, small 4to, cloth, 12s. 6d.

Aid Book to Engineering Enterprise Abroad. By EWING MATHESON, M. Inst. C.E. The book treats of Public Works and Engineering Enterprises in their inception and preliminary arrangement; of the different modes in which money is provided for their accomplishment; and of the economical and technical considerations by which success or failure is determined. The information necessary to the designs of Engineers is classified, as are also those particulars by which Contractors may estimate the cost of works, and Capitalists the probabilities of profit. *Illustrated*, 2 vols., 8vo, 12s. 6d. each.

The Essential Elements of Practical Mechanics; based on the Principle of Work, designed for Engineering Students. By OLIVER BYRNE, formerly Professor of Mathematics, College for Civil Engineers. Third edition, *with 148 wood engravings*, post 8vo, cloth, 7s. 6d.

CONTENTS:

Chap. I. How Work is Measured by a Unit, both with and without reference to a Unit of Time—Chap. 2. The Work of Living Agents, the Influence of Friction, and introduces one of the most beautiful Laws of Motion—Chap. 3. The principles expounded in the first and second chapters are applied to the Motion of Bodies—Chap. 4. The Transmission of Work by simple Machines—Chap. 5. Useful Propositions and Rules.

The Practical Millwright's and Engineer's Ready Reckoner; or Tables for finding the diameter and power of cog-wheels, diameter, weight, and

power of shafts, diameter and strength of bolts, etc. By THOMAS DIXON. Fourth edition, 12mo, cloth, 3s.

Breweries and Maltings: their Arrangement, Construction, Machinery, and Plant. By G. SCAMELL, F.R.I.B.A. Second edition, revised, enlarged, and partly rewritten By F. COLYER, M.I.C.E., M.I.M.E. *With 20 plates*, 8vo, cloth, 18s.

A Practical Treatise on the Manufacture of Starch, Glucose, Starch-Sugar, and Dextrine, based on the German of L. Von Wagner, Professor in the Royal Technical School, Buda Pesth, and other authorities. By JULIUS FRANKEL; edited by ROBERT HUTTER, proprietor of the Philadelphia Starch Works. *With 58 illustrations*, 344 pp., 8vo, cloth, 18s.

A Practical Treatise on Mill-gearing, Wheels, Shafts, Riggers, etc.; for the use of Engineers. By THOMAS BOX. Third edition, *with 11 plates*. Crown 8vo, cloth, 7s. 6d.

Mining Machinery: a Descriptive Treatise on the Machinery, Tools, and other Appliances used in Mining. By G. G. ANDRÉ, F.G.S., Assoc. Inst. C.E., Mem. of the Society of Engineers. Royal 4to, uniform with the Author's *Treatise on Coal Mining*, containing *182 plates*, accurately drawn to scale, with descriptive text, in 2 vols., cloth, 3l. 12s.

CONTENTS:

Machinery for Prospecting, Excavating, Hauling, and Hoisting—Ventilation—Pumping—Treatment of Mineral Products, including Gold and Silver, Copper, Tin, and Lead, Iron, Coal, Sulphur, China Clay, Brick Earth, etc.

Tables for Setting out Curves for Railways, Canals, Roads, etc., varying from a radius of five chains to three miles. By A. KENNEDY and R. W. HACKWOOD. *Illustrated*, 32mo, cloth, 2s. 6d.

The Science and Art of the Manufacture of Portland Cement, with observations on some of its constructive applications. *With 66 illustrations*. By HENRY REID, C.E., Author of 'A Practical Treatise on Concrete,' etc., etc. 8vo, cloth, 18s.

The Draughtsman's Handbook of Plan and Map Drawing; including instructions for the preparation of Engineering, Architectural, and

Mechanical Drawings. *With numerous illustrations in the text, and 33 plates (15 printed in colours).* By G. G. ANDRÉ, F.G.S., Assoc. Inst. C.E. 4to, cloth, 9s.

CONTENTS:

The Drawing Office and its Furnishings—Geometrical Problems—Lines, Dots, and their Combinations—Colours, Shading, Lettering, Bordering, and North Points—Scales—Plotting—Civil Engineers' and Surveyors' Plans—Map Drawing—Mechanical and Architectural Drawing—Copying and Reducing Trigonometrical Formulæ, etc., etc.

The Boiler-maker's and Iron Ship-builder's Companion, comprising a series of original and carefully calculated tables, of the utmost utility to persons interested in the iron trades. By JAMES FODEN, author of 'Mechanical Tables,' etc. Second edition revised, *with illustrations*, crown 8vo, cloth, 5s.

Rock Blasting: a Practical Treatise on the means employed in Blasting Rocks for Industrial Purposes. By G. G. ANDRÉ, F.G.S., Assoc. Inst. C.E. *With 56 illustrations and 12 plates*, 8vo, cloth, 10s. 6d.

Surcharged and different Forms of Retaining Walls. By J. S. TATE. *Illustrated*, 8vo, sewed, 2s.

A Treatise on Ropemaking as practised in public and private Rope-yards, with a Description of the Manufacture, Rules, Tables of Weights, etc., adapted to the Trade, Shipping, Mining, Railways, Builders, etc. By R. CHAPMAN, formerly foreman to Messrs. Huddart and Co., Limehouse, and late Master Ropemaker to H.M. Dockyard, Deptford. Second edition, 12mo, cloth, 3s.

Laxton's Builders' and Contractors' Tables; for the use of Engineers, Architects, Surveyors, Builders, Land Agents, and others. Bricklayer, containing 22 tables, with nearly 30,000 calculations. 4to, cloth, 5s.

Laxton's Builders' and Contractors' Tables. Excavator, Earth, Land, Water, and Gas, containing 53 tables, with nearly 24,000 calculations. 4to, cloth, 5s.

Sanitary Engineering: a Guide to the Construction of Works of Sewerage and House Drainage, with Tables for facilitating the calculations of the Engineer. By BALDWIN LATHAM, C.E., M. Inst. C.E., F.G.S., F.M.S., Past-President of the Society of Engineers. Second edition, *with numerous plates and woodcuts*, 8vo, cloth, 1l. 10s.

Screw Cutting Tables for Engineers and Machinists, giving the values of the different trains of Wheels required to produce Screws of any pitch, calculated by Lord Lindsay, M.P., F.R.S., F.R.A.S., etc. Royal 8vo, cloth, oblong, 2s.

Screw Cutting Tables, for the use of Mechanical Engineers, showing the proper arrangement of Wheels for cutting the Threads of Screws of any required pitch, with a Table for making the Universal Gas-pipe Threads and Taps. By W. A. MARTIN, Engineer. Second edition, royal 8vo, oblong, cloth, 1s., or sewed, 6d.

A Treatise on a Practical Method of Designing Slide-Valve Gears by Simple Geometrical Construction, based upon the principles enunciated in Euclid's Elements, and comprising the various forms of Plain Slide-Valve and Expansion Gearing; together with Stephenson's, Gooch's, and Allan's Link-Motions, as applied either to reversing or to variable expansion combinations. By EDWARD J. COWLING WELCH, Memb. Inst. Mechanical Engineers. Crown 8vo, cloth, 6s.

Cleaning and Scouring: a Manual for Dyers, Laundresses, and for Domestic Use. By S. CHRISTOPHER. 18mo, sewed, 6d.

A Handbook of House Sanitation; for the use of all persons seeking a Healthy Home. A reprint of those portions of Mr. Bailey-Denton's Lectures on Sanitary Engineering, given before the School of Military Engineering, which related to the "Dwelling," enlarged and revised by his Son, E. F. BAILEY-DENTON, C.E., B.A. *With 140 illustrations*, 8vo, cloth, 8s. 6d.

Treatise on Valve-Gears, with special consideration of the Link-Motions of Locomotive Engines. By Dr. GUSTAV ZEUNER. Third edition, revised and enlarged, translated from the German, with the special permission of the author, by MORITZ MÜLLER. *Plates*, 8vo, cloth, 12s. 6d.

A Pocket-Book for Boiler Makers and Steam Users, comprising a variety of useful information for Employer and Workman, Government

Inspectors, Board of Trade Surveyors, Engineers in charge of Works and Slips, Foremen of Manufactories, and the general Steam-using Public. By MAURICE JOHN SEXTON. Second edition, royal 32mo, roan, gilt edges, 5s.

The Strains upon Bridge Girders and Roof Trusses, including the Warren, Lattice, Trellis, Bowstring, and other Forms of Girders, the Curved Roof, and Simple and Compound Trusses. By THOS. CARGILL, C.E.B.A.T., C.D., Assoc. Inst. C.E., Member of the Society of Engineers. *With 64 illustrations, drawn and worked out to scale*, 8vo, cloth, 12s., 6d.

A Practical Treatise on the Steam Engine, containing Plans and Arrangements of Details for Fixed Steam Engines, with Essays on the Principles involved in Design and Construction. By ARTHUR RIGG, Engineer, Member of the Society of Engineers and of the Royal Institution of Great Britain. Demy 4to, *copiously illustrated with woodcuts and 96 plates*, in one Volume, half-bound morocco, 2l. 2s.; or cheaper edition, cloth, 25s.

This work is not, in any sense, an elementary treatise, or history of the steam engine, but is intended to describe examples of Fixed Steam Engines without entering into the wide domain of locomotive or marine practice. To this end illustrations will be given of the most recent arrangements of Horizontal, Vertical, Beam, Pumping, Winding, Portable, Semi-portable, Corliss, Allen, Compound, and other similar Engines, by the most eminent Firms in Great Britain and America. The laws relating to the action and precautions to be observed in the construction of the various details, such as Cylinders, Pistons, Piston-rods, Connecting-rods, Cross-heads, Motion-blocks, Eccentrics, Simple, Expansion, Balanced, and Equilibrium Slide-valves, and Valve-gearing will be minutely dealt with. In this connection will be found articles upon the Velocity of Reciprocating Parts and the Mode of Applying the Indicator, Heat and Expansion of Steam Governors, and the like. It is the writer's desire to draw illustrations from every possible source, and give only those rules that present practice deems correct.

Barlow's Tables of Squares, Cubes, Square Roots, Cube Roots, Reciprocals of all Integer Numbers up to 10,000. Post 8vo, cloth, 6s.

Camus (M.) Treatise on the Teeth of Wheels, demonstrating the best forms which can be given to them for the purposes of Machinery, such as Mill-work and Clock-work, and the art of finding their numbers. Translated from the French, with details of the present practice of Millwrights, Engine Makers, and other Machinists, by ISAAC HAWKINS. Third edition, *with 18 plates*, 8vo, cloth, 5s.

A Practical Treatise on the Science of Land and Engineering Surveying, Levelling, Estimating Quantities, etc., with a general description of the several Instruments required for Surveying, Levelling, Plotting, etc. By H. S. MERRETT. Third edition, *41 plates with illustrations and tables*, royal 8vo, cloth, 12s. 6d.

PRINCIPAL CONTENTS:

Part 1. Introduction and the Principles of Geometry. Part 2. Land Surveying; comprising General Observations—The Chain—Offsets Surveying by the Chain only—Surveying Hilly Ground—To Survey an Estate or Parish by the Chain only—Surveying with the Theodolite—Mining and Town Surveying—Railroad Surveying—Mapping—Division and Laying out of Land—Observations on Enclosures—Plane Trigonometry. Part 3. Levelling—Simple and Compound Levelling—The Level Book—Parliamentary Plan and Section—Levelling with a Theodolite—Gradients—Wooden Curves—To Lay out a Railway Curve—Setting out Widths. Part 4. Calculating Quantities generally for Estimates—Cuttings and Embankments—Tunnels—Brickwork—Ironwork—Timber Measuring. Part 5. Description and Use of Instruments in Surveying and Plotting—The Improved Dumpy Level—Troughton's Level—The Prismatic Compass—Proportional Compass—Box Sextant—Vernier—Pantagraph—Merrett's Improved Quadrant—Improved Computation Scale—The Diagonal Scale—Straight Edge and Sector. Part 6. Logarithms of Numbers—Logarithmic Sines and Co-Sines, Tangents and Co-Tangents—Natural Sines and Co-Sines—Tables for Earthwork, for Setting out Curves, and for various Calculations, etc., etc., etc.

Saws: the History, Development, Action, Classification, and Comparison of Saws of all kinds. By ROBERT GRIMSHAW. *With 220*

illustrations, 4to, cloth, 12s. 6d.

A Supplement to the above; containing additional practical matter, more especially relating to the forms of Saw Teeth for special material and conditions, and to the behaviour of Saws under particular conditions. *With 120 illustrations*, cloth, 9s.

A Guide for the Electric Testing of Telegraph Cables. By Capt. V. HOSKIER, Royal Danish Engineers. *With illustrations*, second edition, crown 8vo, cloth, 4s. 6d.

Laying and Repairing Electric Telegraph Cables. By Capt. V. HOSKIER, Royal Danish Engineers. Crown 8vo, cloth, 3s. 6d.

A Pocket-Book of Practical Rules for the Proportions of Modern Engines and Boilers for Land and Marine purposes. By N. P. BURGH. Seventh edition, royal 32mo, roan, 4s. 6d.

Table of Logarithms of the Natural Numbers, from 1 to 108,000. By CHARLES BABBAGE, Esq., M.A. Stereotyped edition, royal 8vo, cloth, 7s. 6d.

To ensure the correctness of these Tables of Logarithms, they were compared with Callett's, Vega's, Hutton's, Briggs', Gardiner's, and Taylor's Tables of Logarithms, and carefully read by nine different readers; and further, to remove any possibility of an error remaining, the stereotyped sheets were hung up in the Hall at Cambridge University, and a reward offered to anyone who could find an inaccuracy. So correct are these Tables, that since their first issue in 1827 no error has been discovered.

The Steam Engine considered as a Heat Engine: a Treatise on the Theory of the Steam Engine, illustrated by Diagrams, Tables, and Examples from Practice. By JAS. H. COTTERILL, M.A., F.R.S., Professor of Applied Mechanics in the Royal Naval College. 8vo, cloth, 12s. 6d.

The Practice of Hand Turning in Wood, Ivory, Shell, etc., with Instructions for Turning such Work in Metal as maybe required in the Practice of Turning in Wood, Ivory, etc.; also an Appendix on Ornamental Turning. (A book for beginners.) By FRANCIS CAMPIN. Second edition, *with wood engravings*, crown 8vo, cloth, 6s.

CONTENTS:

On Lathes—Turning Tools—Turning Wood—Drilling—Screw Cutting—Miscellaneous Apparatus and Processes—Turning Particular Forms—Staining—Polishing—Spinning Metals—Materials—Ornamental Turning, etc.

Health and Comfort in House Building, or Ventilation with Warm Air by Self-Acting Suction Power, with Review of the mode of Calculating the Draught in Hot-Air Flues, and with some actual Experiments. By J. DRYSDALE, M.D., and J. W. HAYWARD, M.D. Second edition, with Supplement, *with plates*, demy 8vo, cloth, 7s. 6d.

Treatise on Watchwork, Past and Present. By the Rev. H. L. NELTHROPP, M.A., F.S.A. *With 32 illustrations*, crown 8vo, cloth, 6s. 6d.

CONTENTS:

Definitions of Words and Terms used in Watchwork—Tools—Time—Historical Summary—On Calculations of the Numbers for Wheels and Pinions; their Proportional Sizes, Trains, etc.—Of Dial Wheels, or Motion Work—Length of Time of Going without Winding up—The Verge—The Horizontal—The Duplex—The Lever—The Chronometer—Repeating Watches—Keyless Watches—The Pendulum, or Spiral Spring—Compensation—Jewelling of Pivot Holes—Clerkenwell—Fallacies of the Trade—Incapacity of Workmen—How to Choose and Use a Watch, etc.

Spons' Engineers' and Contractors' Illustrated Book of Prices of Machines, Tools, Ironwork, and Contractors' Material; and Engineers' Directory. Third edition, 4to, cloth, 6s.

Algebra Self-Taught. By W. P. HIGGS, M.A., D.Sc., LL.D., Assoc. Inst. C.E., Author of 'A Handbook of the Differential Calculus,' etc. Second edition, crown 8vo, cloth, 2s. 6d.

CONTENTS:

Symbols and the Signs of Operation—The Equation and the Unknown Quantity—Positive and Negative Quantities—

Multiplication—Involution—Exponents—Negative Exponents—
Roots, and the Use of Exponents as Logarithms—Logarithms—
Tables of Logarithms and Proportionate Parts—Transformation of
System of Logarithms—Common Uses of Common Logarithms—
Compound Multiplication and the Binomial Theorem—Division,
Fractions, and Ratio—Continued Proportion—The Series and the
Summation of the Series—Limit of Series—Square and Cube Roots
—Equations—List of Formulæ, etc.

JUST PUBLISHED.

**In super-royal 8vo, 1168 pp., with 2400
illustrations, in 3 Divisions, cloth, price 13s.
6d. each; or 1 vol., cloth, 2l.; or half-morocco,
2l. 8s.**

**A SUPPLEMENT
TO
SPONS' DICTIONARY OF ENGINEERING,
Civil, Mechanical, Military and Naval.
EDITED BY ERNEST SPON, MEMB. SOC.
ENGINEERS.**

The success which has attended the publication of 'SPONS' DICTIONARY OF ENGINEERING' has encouraged the Publishers to use every effort tending to keep the work up to the standard of existing professional knowledge. As the Book has now been some years before the public without addition or revision, there are many subjects of importance which, of necessity, are either not included in its pages, or have been treated somewhat less fully than their present importance demands. With the object, therefore, of remedying these omissions, this Supplement is now being issued. Each subject in it is treated in a thoroughly comprehensive way; but, of course, without repeating the information already included in the body of the work.

The new matter comprises articles upon

Abacus, Counters, Speed Indicators, and Slide Rule.

Agricultural Implements and Machinery.

Air Compressors.

Animal Charcoal Machinery.

Antimony.
Axles and Axle-boxes.
Barn Machinery.
Belts and Belting.
Blasting.
Boilers.
Brakes.
Brick Machinery.
Bridges.
Cages for Mines.
Calculus, Differential and Integral.
Canals.
Carpentry.
Cast Iron.
Cement, Concrete, Limes, and Mortar.
Chimney Shafts.
Coal Cleansing and Washing.
Coal Mining.
Coal Cutting Machines.
Coke Ovens.
Copper.
Docks.
Drainage.
Dredging Machinery.
Dynamo-Electric and Magneto-Electric Machines.
Dynamometers.
Electrical Engineering, Telegraphy, Electric Lighting and its practical details, Telephones.
Engines, Varieties of.
Explosives.
Fans.
Founding, Moulding and the practical work of the Foundry.
Gas, Manufacture of.
Hammers, Steam and other Power.
Heat.
Horse Power.
Hydraulics.
Hydro-geology.

Indicators.
Iron.
Lifts, Hoists, and Elevators.
Lighthouses, Buoys, and Beacons.
Machine Tools.
Materials of Construction.
Meters.
Ores, Machinery and Processes employed to Dress.
Piers.
Pile Driving.
Pneumatic Transmission.
Pumps.
Pyrometers.
Road Locomotives.
Rock Drills.
Rolling Stock.
Sanitary Engineering.
Shafting.
Steel.
Steam Navy.
Stone Machinery.
Tramways.
Well Sinking.

NOW COMPLETE.

With nearly 1500 illustrations, in super-royal 8vo, in 5 Divisions, cloth. Divisions 1 to 4, 13s. 6d. each; Division 5, 17s. 6d.; or 2 vols., cloth, £3 10s.

**SPONS' ENCYCLOPÆDIA
OF THE
INDUSTRIAL ARTS, MANUFACTURES,
AND COMMERCIAL PRODUCTS.
EDITED BY C. G. WARNFORD LOCK, F.L.S.**

Among the more important of the subjects treated of, are the following:—

Acids, 207 pp. 220 figs.
Alcohol, 23 pp. 16 figs.
Alcoholic Liquors, 13 pp.
Alkalies, 89 pp. 78 figs.
Alloys.
Alum.
Asphalt.
Assaying.
Beverages, 89 pp. 29 figs.
Blacks.
Bleaching Powder, 15 pp.
Bleaching, 51 pp. 48 figs.
Candles, 18 pp. 9 figs.
Carbon Bisulphide.
Celluloid, 9 pp.

Cements.
Clay.
Coal-tar Products, 44 pp. 14 figs.
Cocoa, 8 pp.
Coffee, 32 pp. 13 figs.
Cork, 8 pp. 17 figs.
Cotton Manufactures, 62 pp. 57 figs.
Drugs, 38 pp.
Dyeing and Calico Printing, 28 pp. 9 figs.
Dyestuffs, 16 pp.
Electro-Metallurgy, 13 pp.
Explosives, 22 pp. 33 figs.
Feathers.
Fibrous Substances, 92 pp. 79 figs.
Floor-cloth, 16 pp. 21 figs.
Food Preservation, 8 pp.
Fruit, 8 pp.
Fur, 5 pp.
Gas, Coal, 8 pp.
Gems.
Glass, 45 pp. 77 figs.
Graphite, 7 pp.
Hair, 7 pp.
Hair Manufactures.
Hats, 26 pp. 26 figs.
Honey.
Hops.
Horn.
Ice, 10 pp. 14 figs.
Indiarubber Manufactures, 23 pp. 17 figs.
Ink, 17 pp.
Ivory.
Jute Manufactures, 11 pp. 11 figs.
Knitted Fabrics—Hosiery, 15 pp. 13 figs.
Lace, 13 pp. 9 figs.
Leather, 28 pp. 31 figs.
Linen Manufactures, 16 pp. 6 figs.
Manures, 21 pp. 30 figs.

Matches, 17 pp. 38 figs.
Mordants, 13 pp.
Narcotics, 47 pp.
Nuts, 10 pp.
Oils and Fatty Substances, 125 pp.
Paint.
Paper, 26 pp. 23 figs.
Paraffin, 8 pp. 6 figs.
Pearl and Coral, 8 pp.
Perfumes, 10 pp.
Photography, 13 pp. 20 figs.
Pigments, 9 pp. 6 figs.
Pottery, 46 pp. 57 figs.
Printing and Engraving, 20 pp. 8 figs.
Rags.
Resinous and Gummy Substances, 75 pp. 16 figs.
Rope, 16 pp. 17 figs.
Salt, 31 pp. 23 figs.
Silk, 8 pp.
Silk Manufactures, 9 pp. 11 figs.
Skins, 5 pp.
Small Wares, 4 pp.
Soap and Glycerine, 39 pp. 45 figs.
Spices, 16 pp.
Sponge, 5 pp.
Starch, 9 pp. 10 figs.
Sugar, 155 pp. 134 figs.
Sulphur.
Tannin, 18 pp.
Tea, 12 pp.
Timber, 13 pp.
Varnish, 15 pp.
Vinegar, 5 pp.
Wax, 5 pp.
Wool, 2 pp.
Woollen Manufactures, 5s pp. 39 figs.

London: E. & F. N. SPON, 16, Charing Cross.

New York: 44, Murray Street.

FOOTNOTES:

[1] An autograph letter of Philipp Reis to Mr. W. Ladd, the well-known instrument maker of Beak Street, London, describing his telephone, is still preserved, and is now in possession of the Society of Telegraph Engineers and Electricians of London. It is reproduced at p. 81.

[2] As to the difference in quality of the instruments, see the testimony of the maker, Albert of Frankfort, on p. 44. Prof. Pisko (see p. 101) seems to have had a peculiarly imperfect instrument.

[3] Dr. Messel, F.C.S., a former pupil of Reis, and an eye-witness of his early experiments, makes, in a letter to Professor W. F. Barrett, the following very interesting statement: "The original telephone was of a most primitive nature. The transmitting instrument was a bung of a beer-barrel hollowed out, and a cone formed in this way was closed with the skin of a German sausage, which did service as a membrane. To this was fixed with a drop of sealing-wax a little strip of platinum corresponding to the hammer of the ear, and which closed or opened the electric circuit, precisely as in the instruments of a later date. The receiving instrument was a knitting needle surrounded with a coil of wire and placed on a violin to serve as a sounding board. It astonished every one quite as much as the more perfect instruments of Bell now do. The instrument I have described has now passed into the hands of the Telegraph Department of the German Government." [The instrument now in the museum of the Reichs Post-Amt in Berlin is not this, but is the first of the "Improved" Telephones described later by Reis in his "Prospectus" (see p. 85), and is stamped "Philipp Reis," "1863," "No. 1."] S.P.T.

[4] Or sometimes “tension-regulators,” though the latter term is acknowledged by most competent electricians to be indescriptive and open to objection.

[5] See *Die Geschichte und Entwicklung des Elektrischen Fernsprechwesens* (issued officially from the Imperial German Post-office, 1880), p. 7.

[6] The name “Telephone” had already been applied by Sir C. Wheatstone (1831) to an acoustic arrangement for transmitting sounds through wooden rods to a distant place in a purely mechanical manner. It is needless to observe that speech as well as music can be thus transmitted; and though Wheatstone gave telephonic concerts, this does not prove (nor do telephonic concerts given through Reis’s instrument prove) that speech could not be transmitted also. The name “Fernsprecher,” now used in Germany for the Telephone, was only suggested in 1877 by Dr. Stephan, Postmaster of the German Empire, in obedience to the absurd fashion which has raged since 1871 in Germany of rejecting words of classic derivation.

[7] See proceedings in U. S. Court (Dowd suit), Edison’s second answer, and Prescott’s ‘The Speaking Telephone,’ p. 218.

[8] Published volume of Proceedings in the United States Patent Office, before the Commissioner of Patents. Evidence for A. G. Bell, p. 6.

[9] Proc. Soc. Electr. Engin. and Electr. vol. xi. p. 134, 1882.

[10] ‘Electrical Review,’ July 22, 1882, p. 49.

[11] Mr. E. Albert, of the firm of J. W. Albert and Sohn, of Frankfurt, to whom Reis entrusted the manufacture of Telephones for public sale, thus writes: “The most important part was the membrane, because the delicacy of the apparatus depended principally upon that part. As it was not possible to make every membrane equally good, so it came about that instruments of

different degrees of superiority came into use, and various decisions were arrived at as to the ability of the instrument to perform the functions for which it was designed. Those who happened to have a poor instrument were able to hear but little; while those who possessed a good instrument were astonished at its performances. A good instrument reproduced the words sung into it in such a manner that not only the pitch but also the words of the song were perfectly understood, even when the listener was unacquainted with the song and the words.”

M. St. Edmé, of Paris, who contributed to ‘Cosmos,’ vol. xxiv. p. 349, 1864, an article on Reis’s Telephone, of which he had seen an example in König’s *atelier*, said that when the scale was sung it needed a trained ear to distinguish the notes amidst the noises of the receiver. He must have got hold of an uncommonly bad transmitter with a flabby tympanum to have failed so completely.

[12] Letter of Dr. Messel to Professor W. F. Barrett quoted, in Professor Barrett’s memoir, ‘On the Electric Telephone,’ read Nov. 19, 1877, to the Dublin Royal Society. Vide Proc. Roy. Soc. Dubl. 1877.

[13] See Barrett’s ‘Telephones Old and New’ (1878), p. 12.

[14] See Reis’s own remark at bottom of p. 57.

[15] [This was the number formerly accepted on the authority of Despretz as the minimum number of vibrations that could evoke the sensation of a tone in the human ear. The limit now more usually recognized is that of Helmholtz, who assigns from thirty to forty double vibrations per second as the minimum.]—S. P. T.

[16] [The three plates or tables with which Reis accompanied his Memoir, containing a variety of undulatory curves corresponding to various combinations of tones, both of musical concords and of dissonant sounds, are not reprinted in this book in their entirety. Table I. contained three sets, the first of which is

reproduced by photo-lithography in reduced facsimile in [Fig. 47](#), p. 173. It was also reproduced by W. von Legat in his Report from which [Plate I.](#) at end of this book is copied, Fig. 1 of that plate being the same as Fig. 1 of Reis's Table I. Fig. 2 of Plate 1, was in like manner copied by Legat from the first figure of Reis's Table II., and Fig. 3 of Plate I., which represents the curves of a non-harmonious combination is the same as Reis's Table III., the only difference being that in Reis's Table III. the irregular undulations of the resultant curve were emphasised by being labelled 'Dissonanz.']—S. P. T.

[\[17\]](#) [This is true for speech-tones as well as for musical tones. Each kind of tone may be represented by its own characteristic curve.]—S. P. T.

[\[18\]](#) [This is the fundamental principle, not only of the telephone, but of the phonograph; and it is wonderful with what clearness Reis had grasped his principle in 1861.]—S. P. T.

[\[19\]](#) [That is, at any single demagnetisation of the needle, it vibrates and emits the same tone as if it had been struck or mechanically caused to vibrate longitudinally.]—S. P. T.

[\[20\]](#) [This range was simply due to the degree of tension of the tympanum; another tympanum differently stretched, or of different proportions, would have a different range according to circumstances.]—S. P. T.

[\[21\]](#) [The so-called "galvanic tone" heard on opening or closing the circuit was well-known, and Wertheim had shown that this tone was, for any given rod of iron, identical with its "longitudinal tone," *i.e.* the tone produced by striking it on the end so as to produce longitudinal vibrations. But it was one of the most important discoveries in Reis's researches that such a rod could take up *any* tone in obedience to the vibrations forced upon it by periodic interruptions in the magnetising current in the spiral of any degree of rapidity within very

wide limits. The translator has had occasion to examine this point, and has found iron, steel, and cobalt wires varying from 4 to 10 inches in length, including some used by Reis himself as receivers, to be capable of taking up vibrations from as slow as 40 per second to the very shrillest whistle audible to human ears, or exceeding 36,000 per second. It is sometimes also mistakenly supposed that such a wire can respond only to the vibrations of tones that are musical, not to those that are articulate, including both consonants and vowels. This, however, is an entire mistake. For, using such a wire as a receiver (surrounded by its proper coil and mounted with an appropriate sounding board, or, better still, tympanum), in conjunction with a well-adjusted transmitter, the articulation transmitted surpasses that obtainable with any of the ordinary magnetic receivers in distinctness, though not in loudness. This discovery of Reis's is of the greatest importance, especially as some who ought to know better have very unjustly denied the capability of this part of the apparatus to act as a telephone receiver for articulate sounds.]—S. P. T.

[22] [This limit is a mistake of Professor Böttger's. The longitudinal tone of an unstrained iron or steel wire 10 inches long would be a note about four octaves above the middle *c* of the piano; whereas, in fact, any note of the whole piano-gamut down to the lowest note, can be reproduced by such a wire, as stated in preceding footnote.]—S. P. T.

[23] [Professor Böttger had not to wait long for the fulfilment to a very large degree of this anticipation; for within six months Dingler's Journal, in which this article appeared, contained Legat's report on Reis's instruments, in which not only were various modifications in their construction made known, but also the transmission of voice-tones, not yet perfectly but with recognisable modulations and intonations, was recorded. Reis had,

indeed, succeeded nearly as well as this with his first instrument, as his memoir of 1861 shows. See p. 58.]

[24] [Compare ‘*Die Geschichte und Entwicklung des Fernsprechwesens*,’ a pamphlet issued officially in 1880 from the Imperial German Post-Office in Berlin, p. 6.]

[25] [Plate VIII. of the original in Vol. IX. of the *Zeitschrift*.]

[26] [Plate IX. of the original Memoir.]

[27] [This word, as the context and ending of the paragraph shows, should have been spelled *tones*. The letter, written in English by Reis himself, is wonderfully free from inaccuracies of composition; the slip here noted being a most pardonable one since the plural of the German “*ton*” is “*tönen*,” the very pronunciation of which would account for the confusion in the mind of one unaccustomed to write in English. So far as is known, this is the only piece of English composition ever attempted by Reis.—S. P. T.]

[28] [Reis here sketched a figure identical in all its parts with that which a fortnight later was issued in his ‘*Prospectus*.’ His sketch is reproduced in facsimile in Fig. 28.]

[29] [This was the little auxiliary signalling apparatus at the side of the box, placed there for the same reasons as the auxiliary call-bell attached to modern telephones.]

[30] [This word is underscored in Reis’s original letter.]

[31] [Compare Böttger *Polyt. Notizbl.* 1863, p. 81, the notice translated at p. 61 preceding.]—S. P. T.

[32] [This rather obscure passage refers to the call-key or communicator fixed to the side of the instruments, and which as the inventor explains in his *Prospectus* (see p. 87), to be intended, like the call-bell or communicator of modern telephones, as a means of sending signals to the

speaker, and which, as the Prospectus says, can also be used—as any call-bell can—for telegraphing words by a pre-arranged code of signals.]—S. P. T.

[33] [Fig. 30 of this book.]

[34] [References.] *Telephon von Reis* im Jahresbericht des physikalischen Vereins zu Frankfurt-a.-M. für 1860-1861, pag. 57 bis 64. *Müller-Pouillet*, Physik, 1863, 6. Auflage, II pag. 352, Fig. 325. *Berl. Ber.* für 1861, xvii. pag. 171 bis 173. *Der Musiktelegraph* in der “Gartenlaube” 1863, Nr. 51, pag. 807 bis 909. *Aus der Natur* 1862, xxi. pag. 470 bis 484; *König’s Catalog*, 1865, pag. 5.

[35] [This part of the apparatus is in fact a “call,” serving precisely the same function as the call-bell attached to ordinary telephones, by which the subscriber can be “called up” to listen to the instrument. It is not without importance to observe that this function was perfectly well-known at the time; for it was gravely argued during a former telephone law-suit in England that the presence of this “signal-call” at the side of the Reis Transmitter was a proof that it was intended to transmit singing only *and not speech*, or “else there would not have been that little Morse-instrument at the side by which to talk”! This suggestion is, however, self-evidently absurd, because if this had been the case the little electromagnetic Morse telegraph would have been fixed, not on the side of the transmitter but on that of the receiver. Reis himself explains the use of the “call” (see p. 87) in his “Prospectus.”]—S. P. T.

[36] [Professor Pisko seems to have got hold of an unusually unfortunate specimen of the instrument if he could make it neither speak nor sing. His transmitter must have been in exceedingly bad condition to fail so completely.]

[37] This error has been copied by Count du Moncel, along with the other defects of the article, into the fifth

volume of his ‘Applications of Electricity,’ published in 1878. It is rather amusing now to read, at p. 106, of Du Moncel’s treatise that “Heisler” (*sic*) “pretends” that the telephone of “Reuss,” which “appears” to have been invented “anterior to the year 1866,” was capable of transmitting vocal melodies! Count du Moncel, though he has since posed as an authority on the telephone, did not in 1878 shine in that capacity, for on the very same page of the Count’s book may be found the following astounding sentiment:—“*If it is true, as Sir W. Thomson has assured us, that at the Philadelphia Exhibition of 1876 there was a telegraphic system transmitting words, we may recognize,*” &c. Count du Moncel has since found out that it is true that there was a Telephone in Philadelphia in 1876: perhaps he will next discover that “Reuss” did, “anterior to the year 1866,” actually “appear” to transmit not only what “Heisler” “pretends” he did, but that he also transmitted spoken words.—S. P. T.

[38] Ueber Fortpflanzung der Töne auf willkürlich weite Entfernungen, mit Hülfe der Elektrizität (Telephonie). Polyt. Journ. clxviii. 185; aus Böttger’s Notizbl. 1863, Nr. 6. [See translation on page 61.]

[39] ‘Philosophical Magazine,’ April 1882.

[40] ‘Atti del R. Istituto Veneto di Scienze,’ vol. vi. ser. 5.

[41] Proc. Roy. Soc. No. 218, 1882.

[42] See Proc. Roy. Dubl. Soc. Feb. 17, 1879.

[43] Vide ‘The Electrician,’ Feb. 10, 1883.

[44] Journal Soc. Electr. Engin. and Electricians, vol. xii. p. 137.

[45] Proc. Physical Soc. vol. ii. p. 259, 1878.

[46] ‘Journal Soc. Telegraphic Engineers,’ vol. iv. p. 117, 1874.

[47] The term “semi-conductor” is very rarely used by electricians, who prefer the term “partial conductor” as being more correct. Moreover, electricians, from Faraday downwards, are practically agreed in calling plumbago a good conductor, and worthy of being classified by reason of its high conductivity along with the metals. The substances known as “semi-conductors” are those given in Ferguson’s ‘Electricity,’ p. 49 (edition of 1873), namely, alcohol, ether, dry-wood, marble, paper, straw, and ice. Mascart and other eminent authorities agree in this classification. It would tax even Mr. Edison’s unrivalled ingenuity to make of these materials a transmitter that should alter its resistance by pressure!

[48] Lüdte’s German Patent, dated Jan. 12, 1878, describes a “Universal Telephone” in which a tympanum was applied to convey vibrations to an interruptor made of hard coke-carbon.

[49] See Prescott’s ‘Speaking Telephone,’ p. 158.

[50] ‘British Patent,’ No. 1874, of the year 1876 (dated 4th May).

[51] Prescott, ‘Speaking Telephone,’ p. 203.

[52] Yet Bell’s claim (British Patent Specification) runs: “I claim the production of any given sound or sounds from the *armature* of the receiving instrument.”

[53] In making these comparisons in parallel columns, I wish to repudiate in the most emphatic way any sinister inference that might be drawn as to Graham Bell’s use of descriptions and curves identical in so many points with those of Reis. For, in the first place, I believe Professor Bell to be incapable of such contemptible appropriations, and the candour with which he has himself invited comparison by giving various references to Reis’s papers, itself precludes such inference. In the second place, I do not think that at the date of these quotations Bell understood German sufficiently well to comprehend Reis’s very precise statement of the problem of the

Telephone. I simply exhibit these parallel extracts to show the thoroughness with which Reis had grappled with the problem with which, fourteen years later, Bell also grappled; and to prove in the most irrefragable manner, from the necessary identity in the terms selected for expressing the facts of the solution of the problem, that the problem to which each found a solution was identical. The circumstance that does, however, puzzle me, and which does not appear in these parallel extracts, is that, whilst in his original memoir, Reis speaks in detail of the auditory ossicles and their movements as having suggested his transmitter, and casually mentions the phonautograph of Scott in support of his views, Bell, in his original lecture before the American Academy, speaks in detail of Scott's phonautograph as having suggested his transmitter, and casually refers to the auditory ossicles and their movements.

[54] Reis's failures were chiefly with the vowels, Bell's more particularly with the consonants. Reis's contacts were liable to break, and the following-springs of his contact-regulators too little pliable. Bell's transmitter could not open and close the circuit proportionally with the motions of the tympanum, and owing to the sluggishness due to self-induction in the coils of his telephone, the induced undulations of the current failed to come up in suddenness to those of the tympanum. In consequence *whip* sounded like *whim*, and *kiss* like *kith*, even in the perfected Bell Telephones made two years after Bell's first "improvements" in telephony were patented.

[55] The following very remarkable passage occurs in the evidence given by Professor Graham Bell concerning Reis's Telephones. (See published volume of 'Proceedings in the United States Patent Office before the Commissioner of Patents.' *Evidence for A. G. Bell*, p. 14.)

Question 37. "If a Reis Telephone, made in accordance with the descriptions published before the

earliest dates of your invention, would in use transmit and receive articulate speech as perfectly as the instruments did which were used by you on June 25, 1876, at the Centennial, would it be proof to you that such Reis's Telephones operated by the use of undulatory movements of electricity in substantially the same way as your instruments did upon the occasion referred to?"

Answer by Bell. "The supposition contained in the question cannot be supposed. Were the question put that if I were to hear an instrument give forth articulate speech transmitted electrically as perfectly as my instruments did on the occasion referred to in the question, I would hold this as proof that the instrument had been operated by undulatory movements of electricity, I would unhesitatingly answer, Yes."

Surely no better authority is needed to support the proposition that if Reis made his Telephone speak, as he said he did, he employed undulatory currents.

Transcriber's notes:

In the text version, italics are represented by `_underscores_`, and bold, black letter and spaced text by `=equals=` symbols.

Superscripts are represented by `^{ }` and subscripts by `_{}`

The parallel columns making comparisons between Reis and Bell on p. 171 and p. 176, have, in the text version, been rendered as alternating sections with different indents.

Keys have been used in the large table split across pp.180 and 181 to make it readable within the constraints of a 72 column page.

The html and epub versions contain an auto-generated table of contents and the title page of the work has been used to create a cover image.

Missing or incorrect punctuation has been repaired. Inconsistent hyphenation, and incorrect spellings in quoted passages e.g. pp.81-85 have been left as printed, as have:—
“Electro-magnet” and “electromagnet”,
“Water-Wheels”, “Water-wheels” and “Waterwheels” and
“Make-and-brake” and “make-or-break”

In the html and epub versions, dittos are replaced by the text to allow alignment of text for easier reading.

The following queries have been noted in the text but not corrected unless noted in the note:

p. 3. “Senckenburg” is more commonly (and especially in German documents of the period), written as “Senckenberg”.

p. 6. “Geissen” has been corrected to Giessen.

p. 29. In the section heading, “B” has been italicised to match all the other letter headings.

p. 43. Pitch is notated using bars over the note letter. This has been transcribed using tick marks e.g. this page has a c with 3 bars which is transcribed as c”’. In the same way, on p. 58. and p. 98 an f with 2 horizontal lines is transcribed as f” and on p. 86, there is a c’.

p. 61. “vol. clxviii.”, a space is inserted after vol.

p. 82. “quiksilver” has been left as written.

p. 88. “~” has been used in the text version to represent a concave arc.

p. 121. “diappointment” has been corrected to “disappointment”.

In the Supplement, occasional items are not in the correct alphabetical order.

*** END OF THE PROJECT GUTENBERG EBOOK PHILIPP REIS:
INVENTOR OF THE TELEPHONE ***

Updated editions will replace the previous one—the old editions will be renamed.

Creating the works from print editions not protected by U.S. copyright law means that no one owns a United States copyright in these works, so the Foundation (and you!) can copy and distribute it in the United States without permission and without paying copyright royalties. Special rules, set forth in the General Terms of Use part of this license, apply to copying and distributing Project Gutenberg™ electronic works to protect the PROJECT GUTENBERG™ concept and trademark. Project Gutenberg is a registered trademark, and may not be used if you charge for an eBook, except by following the terms of the trademark license, including paying royalties for use of the Project Gutenberg trademark. If you do not charge anything for copies of this eBook, complying with the trademark license is very easy. You may use this eBook for nearly any purpose such as creation of derivative works, reports, performances and research. Project Gutenberg eBooks may be modified and printed and given away—you may do practically ANYTHING in the United States with eBooks not protected by U.S. copyright law. Redistribution is subject to the trademark license, especially commercial redistribution.

START: FULL LICENSE

THE FULL PROJECT GUTENBERG™ LICENSE

PLEASE READ THIS BEFORE YOU DISTRIBUTE OR USE
THIS WORK

To protect the Project Gutenberg™ mission of promoting the free distribution of electronic works, by using or distributing this work (or any other work associated in any way with the phrase “Project Gutenberg”), you agree to comply with all the terms of the Full Project Gutenberg License available with this file or online at www.gutenberg.org/license.

Section 1. General Terms of Use and Redistributing Project Gutenberg electronic works

1.A. By reading or using any part of this Project Gutenberg electronic work, you indicate that you have read, understand, agree to and accept all the terms of this license and intellectual property (trademark/copyright) agreement. If you do not agree to abide by all the terms of this agreement, you must cease using and return or destroy all copies of Project Gutenberg electronic works in your possession. If you paid a fee for obtaining a copy of or access to a Project Gutenberg electronic work and you do not agree to be bound by the terms of this agreement, you may obtain a refund from the person or entity to whom you paid the fee as set forth in paragraph 1.E.8.

1.B. “Project Gutenberg” is a registered trademark. It may only be used on or associated in any way with an electronic work by people who agree to be bound by the terms of this agreement. There are a few things that you can do with most Project Gutenberg electronic works even without complying with the full terms of this agreement. See paragraph 1.C below. There are a lot of things you can do with Project Gutenberg electronic works if you follow the terms of this agreement and help preserve free future access to Project Gutenberg electronic works. See paragraph 1.E below.

1.C. The Project Gutenberg Literary Archive Foundation (“the Foundation” or PGLAF), owns a compilation copyright in the collection of Project Gutenberg electronic works. Nearly all the individual works in the collection are in the public domain in the United States. If an individual work is unprotected by copyright law in the United States and you are located in the United States, we do

not claim a right to prevent you from copying, distributing, performing, displaying or creating derivative works based on the work as long as all references to Project Gutenberg are removed. Of course, we hope that you will support the Project Gutenberg mission of promoting free access to electronic works by freely sharing Project Gutenberg works in compliance with the terms of this agreement for keeping the Project Gutenberg name associated with the work. You can easily comply with the terms of this agreement by keeping this work in the same format with its attached full Project Gutenberg License when you share it without charge with others.

1.D. The copyright laws of the place where you are located also govern what you can do with this work. Copyright laws in most countries are in a constant state of change. If you are outside the United States, check the laws of your country in addition to the terms of this agreement before downloading, copying, displaying, performing, distributing or creating derivative works based on this work or any other Project Gutenberg work. The Foundation makes no representations concerning the copyright status of any work in any country other than the United States.

1.E. Unless you have removed all references to Project Gutenberg:

1.E.1. The following sentence, with active links to, or other immediate access to, the full Project Gutenberg License must appear prominently whenever any copy of a Project Gutenberg work (any work on which the phrase “Project Gutenberg” appears, or with which the phrase “Project Gutenberg” is associated) is accessed, displayed, performed, viewed, copied or distributed:

This eBook is for the use of anyone anywhere in the United States and most other parts of the world at no cost and with almost no restrictions whatsoever. You may copy it, give it away or re-use it under the terms of the Project Gutenberg™ License included with this eBook or online at www.gutenberg.org. If you are not located in the United States, you will have to check the laws of the country where you are located before using this eBook.

1.E.2. If an individual Project Gutenberg electronic work is derived from texts not protected by U.S. copyright law (does not contain a notice indicating that it is posted with permission of the copyright holder), the work can be copied and distributed to anyone in the United States without paying any fees or charges. If you are redistributing or providing access to a work with the phrase “Project Gutenberg” associated with or appearing on the work, you must comply either with the requirements of paragraphs 1.E.1 through 1.E.7 or obtain permission for the use of the work and the Project Gutenberg trademark as set forth in paragraphs 1.E.8 or 1.E.9.

1.E.3. If an individual Project Gutenberg electronic work is posted with the permission of the copyright holder, your use and distribution must comply with both paragraphs 1.E.1 through 1.E.7 and any additional terms imposed by the copyright holder. Additional terms will be linked to the Project Gutenberg License for all works posted with the permission of the copyright holder found at the beginning of this work.

1.E.4. Do not unlink or detach or remove the full Project Gutenberg License terms from this work, or any files containing a part of this work or any other work associated with Project Gutenberg.

1.E.5. Do not copy, display, perform, distribute or redistribute this electronic work, or any part of this electronic work, without prominently displaying the sentence set forth in paragraph 1.E.1 with active links or immediate access to the full terms of the Project Gutenberg License.

1.E.6. You may convert to and distribute this work in any binary, compressed, marked up, nonproprietary or proprietary form, including any word processing or hypertext form. However, if you provide access to or distribute copies of a Project Gutenberg work in a format other than “Plain Vanilla ASCII” or other format used in the official version posted on the official Project Gutenberg website (www.gutenberg.org), you must, at no additional cost, fee or expense to the user, provide a copy, a means of exporting a copy, or a means of obtaining a copy upon request, of the work in its original “Plain Vanilla ASCII” or other form. Any alternate format must

include the full Project Gutenberg License as specified in paragraph 1.E.1.

1.E.7. Do not charge a fee for access to, viewing, displaying, performing, copying or distributing any Project Gutenberg works unless you comply with paragraph 1.E.8 or 1.E.9.

1.E.8. You may charge a reasonable fee for copies of or providing access to or distributing Project Gutenberg electronic works provided that:

- You pay a royalty fee of 20% of the gross profits you derive from the use of Project Gutenberg works calculated using the method you already use to calculate your applicable taxes. The fee is owed to the owner of the Project Gutenberg trademark, but he has agreed to donate royalties under this paragraph to the Project Gutenberg Literary Archive Foundation. Royalty payments must be paid within 60 days following each date on which you prepare (or are legally required to prepare) your periodic tax returns. Royalty payments should be clearly marked as such and sent to the Project Gutenberg Literary Archive Foundation at the address specified in Section 4, “Information about donations to the Project Gutenberg Literary Archive Foundation.”
- You provide a full refund of any money paid by a user who notifies you in writing (or by e-mail) within 30 days of receipt that s/he does not agree to the terms of the full Project Gutenberg™ License. You must require such a user to return or destroy all copies of the works possessed in a physical medium and discontinue all use of and all access to other copies of Project Gutenberg™ works.
- You provide, in accordance with paragraph 1.F.3, a full refund of any money paid for a work or a replacement copy, if a defect in the electronic work is discovered and reported to you within 90 days of receipt of the work.
- You comply with all other terms of this agreement for free distribution of Project Gutenberg™ works.

1.E.9. If you wish to charge a fee or distribute a Project Gutenberg™ electronic work or group of works on different terms than are set forth in this agreement, you must obtain permission in writing from the Project Gutenberg Literary Archive Foundation, the manager of the Project Gutenberg™ trademark. Contact the Foundation as set forth in Section 3 below.

1.F.

1.F.1. Project Gutenberg volunteers and employees expend considerable effort to identify, do copyright research on, transcribe and proofread works not protected by U.S. copyright law in creating the Project Gutenberg™ collection. Despite these efforts, Project Gutenberg™ electronic works, and the medium on which they may be stored, may contain “Defects,” such as, but not limited to, incomplete, inaccurate or corrupt data, transcription errors, a copyright or other intellectual property infringement, a defective or damaged disk or other medium, a computer virus, or computer codes that damage or cannot be read by your equipment.

1.F.2. LIMITED WARRANTY, DISCLAIMER OF DAMAGES - Except for the “Right of Replacement or Refund” described in paragraph 1.F.3, the Project Gutenberg Literary Archive Foundation, the owner of the Project Gutenberg™ trademark, and any other party distributing a Project Gutenberg™ electronic work under this agreement, disclaim all liability to you for damages, costs and expenses, including legal fees. YOU AGREE THAT YOU HAVE NO REMEDIES FOR NEGLIGENCE, STRICT LIABILITY, BREACH OF WARRANTY OR BREACH OF CONTRACT EXCEPT THOSE PROVIDED IN PARAGRAPH 1.F.3. YOU AGREE THAT THE FOUNDATION, THE TRADEMARK OWNER, AND ANY DISTRIBUTOR UNDER THIS AGREEMENT WILL NOT BE LIABLE TO YOU FOR ACTUAL, DIRECT, INDIRECT, CONSEQUENTIAL, PUNITIVE OR INCIDENTAL DAMAGES EVEN IF YOU GIVE NOTICE OF THE POSSIBILITY OF SUCH DAMAGE.

1.F.3. LIMITED RIGHT OF REPLACEMENT OR REFUND - If you discover a defect in this electronic work within 90 days of receiving it, you can receive a refund of the money (if any) you paid

for it by sending a written explanation to the person you received the work from. If you received the work on a physical medium, you must return the medium with your written explanation. The person or entity that provided you with the defective work may elect to provide a replacement copy in lieu of a refund. If you received the work electronically, the person or entity providing it to you may choose to give you a second opportunity to receive the work electronically in lieu of a refund. If the second copy is also defective, you may demand a refund in writing without further opportunities to fix the problem.

1.F.4. Except for the limited right of replacement or refund set forth in paragraph 1.F.3, this work is provided to you ‘AS-IS’, WITH NO OTHER WARRANTIES OF ANY KIND, EXPRESS OR IMPLIED, INCLUDING BUT NOT LIMITED TO WARRANTIES OF MERCHANTABILITY OR FITNESS FOR ANY PURPOSE.

1.F.5. Some states do not allow disclaimers of certain implied warranties or the exclusion or limitation of certain types of damages. If any disclaimer or limitation set forth in this agreement violates the law of the state applicable to this agreement, the agreement shall be interpreted to make the maximum disclaimer or limitation permitted by the applicable state law. The invalidity or unenforceability of any provision of this agreement shall not void the remaining provisions.

1.F.6. INDEMNITY - You agree to indemnify and hold the Foundation, the trademark owner, any agent or employee of the Foundation, anyone providing copies of Project Gutenberg™ electronic works in accordance with this agreement, and any volunteers associated with the production, promotion and distribution of Project Gutenberg™ electronic works, harmless from all liability, costs and expenses, including legal fees, that arise directly or indirectly from any of the following which you do or cause to occur: (a) distribution of this or any Project Gutenberg work, (b) alteration, modification, or additions or deletions to any Project Gutenberg work, and (c) any Defect you cause.

Section 2. Information about the Mission of Project Gutenberg

Project Gutenberg is synonymous with the free distribution of electronic works in formats readable by the widest variety of computers including obsolete, old, middle-aged and new computers. It exists because of the efforts of hundreds of volunteers and donations from people in all walks of life.

Volunteers and financial support to provide volunteers with the assistance they need are critical to reaching Project Gutenberg's goals and ensuring that the Project Gutenberg collection will remain freely available for generations to come. In 2001, the Project Gutenberg Literary Archive Foundation was created to provide a secure and permanent future for Project Gutenberg and future generations. To learn more about the Project Gutenberg Literary Archive Foundation and how your efforts and donations can help, see Sections 3 and 4 and the Foundation information page at www.gutenberg.org.

Section 3. Information about the Project Gutenberg Literary Archive Foundation

The Project Gutenberg Literary Archive Foundation is a non-profit 501(c)(3) educational corporation organized under the laws of the state of Mississippi and granted tax exempt status by the Internal Revenue Service. The Foundation's EIN or federal tax identification number is 64-6221541. Contributions to the Project Gutenberg Literary Archive Foundation are tax deductible to the full extent permitted by U.S. federal laws and your state's laws.

The Foundation's business office is located at 41 Watchung Plaza #516, Montclair NJ 07042, USA, +1 (862) 621-9288. Email contact links and up to date contact information can be found at the Foundation's website and official page at www.gutenberg.org/contact

Section 4. Information about Donations to the Project Gutenberg Literary Archive Foundation

Project Gutenberg™ depends upon and cannot survive without widespread public support and donations to carry out its mission of

increasing the number of public domain and licensed works that can be freely distributed in machine-readable form accessible by the widest array of equipment including outdated equipment. Many small donations (\$1 to \$5,000) are particularly important to maintaining tax exempt status with the IRS.

The Foundation is committed to complying with the laws regulating charities and charitable donations in all 50 states of the United States. Compliance requirements are not uniform and it takes a considerable effort, much paperwork and many fees to meet and keep up with these requirements. We do not solicit donations in locations where we have not received written confirmation of compliance. To SEND DONATIONS or determine the status of compliance for any particular state visit www.gutenberg.org/donate.

While we cannot and do not solicit contributions from states where we have not met the solicitation requirements, we know of no prohibition against accepting unsolicited donations from donors in such states who approach us with offers to donate.

International donations are gratefully accepted, but we cannot make any statements concerning tax treatment of donations received from outside the United States. U.S. laws alone swamp our small staff.

Please check the Project Gutenberg web pages for current donation methods and addresses. Donations are accepted in a number of other ways including checks, online payments and credit card donations. To donate, please visit: www.gutenberg.org/donate.

Section 5. General Information About Project Gutenberg electronic works

Professor Michael S. Hart was the originator of the Project Gutenberg concept of a library of electronic works that could be freely shared with anyone. For forty years, he produced and distributed Project Gutenberg eBooks with only a loose network of volunteer support.

Project Gutenberg eBooks are often created from several printed editions, all of which are confirmed as not protected by copyright in the U.S. unless a copyright notice is included. Thus, we do not

necessarily keep eBooks in compliance with any particular paper edition.

Most people start at our website which has the main PG search facility: www.gutenberg.org.

This website includes information about Project Gutenberg, including how to make donations to the Project Gutenberg Literary Archive Foundation, how to help produce our new eBooks, and how to subscribe to our email newsletter to hear about new eBooks.